

**Pioneer**

---

DVD AV RECEIVER

**AVH-P3150DVD**

**SUPER TUNER III D**

Operation Manual

*English*

## Thank you for purchasing this PIONEER product.

Please read through this manual before using the product for the first time, to ensure proper use. *After reading, please keep the manual in a safe and accessible place for future reference.*



### Be sure to read this

- DVD video disc region numbers 7
- When an operation is prohibited 8
- Handling guideline of discs and player 94

### 01

#### Precautions

- IMPORTANT SAFEGUARDS 5
- To ensure safe driving 5
- To avoid battery exhaustion 6

### 02

#### Before You Start

- About this unit 7
- About this manual 7
- Visit our website 7
- Features 7
- When an operation is prohibited 8
- Resetting the microprocessor 8
- Feature demo mode 9
- Use and care of the remote control 9

### 03

#### What's what

- Head unit 10
- Remote control 11

### 04

#### Basic Operations

- Power ON/OFF 14
- Selecting a source 14
- Adjusting the volume 15
- Touch panel key basic operation 15
- Built-in DVD player basic operations 17

### 05

#### Radio

- Listening to the radio 19
- Storing and recalling broadcast frequencies 19
- Introduction of advanced tuner operation 20
- Storing the strongest broadcast frequencies 20
- Tuning in strong signals 20

### 06

#### Playing DVD discs

- Watching a DVD 21
- Selecting titles from the title list 22
- Displaying information of DVD-VR 22
- Skipping back or forward to another title 22
- Operating the DVD menu 22
- Selecting the play mode 23
- Resume playback (Bookmark) 23
- CM skip/CM back 23
- Frame-by-frame playback 23
- Slow motion playback 23
- Pausing playback 24
- Searching for the part you want to play 24
- Changing audio language during playback (Multi-audio) 24
- Changing the subtitle language during playback (Multi-subtitle) 25
- Changing the viewing angle during playback (Multi-angle) 25
- Return to the specified scene 25
- Automatic playback of DVDs 25
- Introduction of advanced DVD operation 25
- Repeating play 26
- Selecting audio output 26

### 07

#### Playing Video CDs

- Watching a Video CD 27
- PBC playback 27
- Frame-by-frame playback 28
- Slow motion playback 28
- Pausing playback 28
- Searching for a desired scene, starting playback from a specified time 28
- Introduction of advanced Video CD operation 28
- Repeating play 29
- Selecting audio output 29

### 08

#### Playing CDs

- Listening to a CD 30
- Selecting tracks from the track title list 30
- Pausing playback 30

- Switching the media file type **31**
- Using advanced sound retriever **31**
- Introduction of advanced CD operation **31**
- Repeating play **31**
- Playing tracks in random order **31**
- Scanning tracks of a CD **31**
- 09 Playing compressed audio**
  - Listening to compressed audio **32**
  - Selecting files from the file name list **33**
  - Pausing playback **33**
  - Switching the media file type **33**
  - Using advanced sound retriever **33**
  - Introduction of advanced compressed audio operation **33**
  - Repeating play **34**
  - Playing tracks in random order **34**
  - Scanning folders and tracks **34**
- 10 Playing DivX/JPEG files**
  - Watching a DivX/JPEG **35**
  - Viewing a JPEG slideshow **36**
  - Playing DivX® VOD content **36**
  - Selecting files from the file name list **36**
  - Displaying text information on DivX/JPEG disc **37**
  - Pausing playback **37**
  - Switching the media file type **37**
  - Searching for the part you want to play **37**
  - Changing audio language during playback (Multi-audio) **37**
  - Changing the subtitle language during playback (Multi-subtitle) **37**
  - Capture an image in JPEG files **37**
  - Introduction of advanced DivX/JPEG operation **38**
  - Repeating play **38**
  - Playing tracks in random order **38**
- 11 Playing songs in a USB storage device**
  - Basic Operations **39**
  - Selecting files from the file name list **39**
  - Pausing compressed audio playback **40**
  - Switching the media file type **40**
  - Using advanced sound retriever **40**
  - Introduction to advanced operations **40**
- 12 Using iPod**
  - Basic Operations **41**
  - Playing video **42**
  - Browsing for a song/video **42**
  - Displaying text information on iPod Video **43**
  - Pausing playback **43**
  - Using advanced sound retriever **43**
  - Repeating play **43**
  - Playing songs/videos in a random order (shuffle) **44**
  - Playing all songs in a random order (shuffle all) **44**
  - Operating this unit's iPod function from your iPod **44**
  - Selecting songs from lists related to the currently playing song **44**
  - Changing audiobook speed **44**
  - Changing the screen mode **45**
- 13 Audio Adjustments**
  - Introduction of audio adjustments **46**
  - Using balance adjustment **46**
  - Using the equalizer **46**
  - Adjusting loudness **47**
  - Using subwoofer output **47**
  - Boosting the bass **47**
  - Using the high pass filter **48**
  - Adjusting source levels **48**
- 14 Setting up the DVD player**
  - Introduction of DVD setup adjustments **49**
  - Setting the subtitle language **49**
  - Setting the audio language **49**
  - Setting the menu language **50**
  - Setting the angle icon display **50**
  - Setting the aspect ratio **50**

- Setting the slide show interval **50**
- Setting the parental lock **51**
- Setting the DivX subtitle file **51**
- Displaying your DivX® VOD registration code **52**
- Setting for digital output **52**

## **15 Initial Settings**

- Adjusting initial settings **53**
- Switching the auxiliary setting **53**
- Setting the FM tuning step **53**
- Setting the AM tuning step **53**
- Setting the rear output and subwoofer controller **54**
- Switching the sound muting/attenuation **54**
- Setting the TV signal **55**
- Entering PIN code for Bluetooth wireless connection **55**
- Correcting distorted sound **55**
- Auto TA and EQ (auto-time alignment and auto-equalizing) **55**
- Resetting the audio functions **56**

## **16 System settings**

- Introduction of system adjustments **57**
- Changing the wide screen mode **57**
- Changing the picture adjustment **58**
- Setting the AV input **58**
- Setting the clock **59**
- Setting for rear view camera (back up camera) **59**

## **17 Entertainment settings**

- Introduction of entertainment settings **60**
- Selecting the background display **60**
- Selecting the illumination color **60**
- Selecting the OSD color **61**

## **18 Other Functions**

- Setting remote control code type **62**
- Adjusting the response positions of the touch panels (Touch Panel Calibration) **62**

- Using the AUX source **63**
- Using the external unit **64**
- Using the PGM button **64**

## **19 Available accessories**

- Multi-CD Player **65**
- Bluetooth Audio **67**
- Bluetooth Telephone **69**
- TV tuner **76**
- Digital Signal Processor **77**

## **Additional Information**

- Troubleshooting **88**
- Error messages **90**
- Understanding auto TA and EQ error messages **92**
- Understanding messages **93**
- Handling guideline of discs and player **94**
- DVD discs **94**
- DVD-R/DVD-RW discs **95**
- AVCHD recorded discs **95**
- CD-R/CD-RW discs **95**
- Dual Discs **95**
- Compressed audio compatibility **96**
- Handling guideline and supplemental information **96**
- Example of a hierarchy **97**
- iPod compatibility **97**
- About handling the iPod **98**
- JPEG picture files **98**
- DivX video files **98**
- Using the display correctly **99**
- Language code chart for DVD **101**
- Copyright and trademark notice **102**
- Terms **104**
- Specifications **107**

## **Index 109**

## Precautions

### IMPORTANT SAFEGUARDS

Please read all of these instructions regarding your display and retain them for future reference.

- 1 **Read this manual fully and carefully before operating your display.**
- 2 **Keep this manual handy as a reference for operating procedures and safety information.**
- 3 **Pay close attention to all warnings in this manual and follow the instructions carefully.**
- 4 **Do not allow other persons to use this system until they have read and understood the operating instructions.**
- 5 **Do not install the display where it may (i) obstruct the driver's vision, (ii) impair the performance of any of the vehicle's operating systems or safety features, including air bags, hazard lamp buttons or (iii) impair the driver's ability to safely operate the vehicle.**
- 6 **Do not operate this display if doing so in any way will divert your attention from the safe operation of your vehicle. Always observe safe driving rules and follow all existing traffic regulations. If you experience difficulty in operating the system or reading the display, park your vehicle in a safe location and make necessary adjustments.**
- 7 **Please remember to wear your seat belt at all times while operating your vehicle. If you are ever in an accident, your injuries can be considerably more severe if your seat belt is not properly buckled.**
- 8 **Never use headphones while driving.**
- 9 **To promote safety, certain functions are disabled unless the parking brake is on, and the vehicle is not in motion.**
- 10 **Never set the volume of your display so high that you cannot hear outside traffic and emergency vehicles.**

### WARNING

- **Do not attempt to install or service your display by yourself. Installation or servicing of the display by persons without training and experience in electronic equipment and automotive accessories may be dangerous and could expose you to the risk of electric shock or other hazards.** 

### To ensure safe driving

#### WARNING

- **LIGHT GREEN LEAD AT POWER CONNECTOR IS DESIGNED TO DETECT PARKED STATUS AND MUST BE CONNECTED TO THE POWER SUPPLY SIDE OF THE PARKING BRAKE SWITCH. IMPROPER CONNECTION OR USE OF THIS LEAD MAY VIOLATE APPLICABLE LAW AND MAY RESULT IN SERIOUS INJURY OR DAMAGE.**
- To avoid the risk of damage and injury and the potential violation of applicable laws, this unit is not for use with a video screen that is visible to the driver.
- To avoid the risk of accident and the potential violation of applicable laws, the front DVD or TV (sold separately) feature should never be used while the vehicle is being driven. Also, rear displays should not be in a location where they are visibly distracting to the driver.
- In some countries or states the viewing of images on a display inside a vehicle even by persons other than the driver may be illegal. Where such regulations apply, they must be obeyed and this unit's DVD features should not be used.

When you attempt to watch a DVD, Video CD or TV while driving, the warning **Viewing of front seat video source while driving is strictly prohibited.** will appear on the front display.

To watch a DVD, Video CD or TV on the front display, park your vehicle in a safe place and apply the parking brake.

### When using a display connected to V OUT

This unit's **V OUT** is for connection of a display to enable passengers in the rear seats to watch the DVD or TV.



#### **WARNING**

**NEVER** install the rear display in a location that enables the driver to watch the DVD or TV while driving.

### When using a rear view camera

With an optional rear view camera, you are able to use this unit as an aid to keep an eye on trailers, or backing into a tight parking spot.



#### **WARNING**

- **SCREEN IMAGE MAY APPEAR REVERSED.**
- **USE INPUT ONLY FOR REVERSE OR MIRROR IMAGE REAR VIEW CAMERA. OTHER USE MAY RESULT IN INJURY OR DAMAGE.**



#### **CAUTION**

- The rear view camera function is to be used as an aid to keep an eye on trailers, or while backing up. Do not use for entertainment purposes.
- Please note that the edges of the rear view camera images may differ slightly according to whether full screen images are displayed when backing up, and whether the images are used for checking the rear when the vehicle is moving forward. 

### To avoid battery exhaustion

Be sure to run the vehicle engine while using this unit. Using this unit without running the engine can result in battery drainage.

- When no power is supplied to this unit because of a replacement of the vehicle battery or for some similar reason, the microcomputer of this unit is returned to its initial condition. We recommend that you transcribe the audio adjustment data.



#### **WARNING**

Do not use with vehicles that do not feature an ACC position. 

## Before You Start

### About this unit

#### CAUTION

- Do not allow this unit to come into contact with liquids. Electrical shock could result. Also, damage to this unit, smoke, and overheating could result from contact with liquids.
- "CLASS 1 LASER PRODUCT"  
This product contains a laser diode of higher class than 1. To ensure continued safety, do not remove any covers or attempt to gain access to the inside of the product. Refer all servicing to qualified personnel.
- Keep this manual handy as a reference for operating procedures and precautions.
- Always keep the volume low enough so that you can hear sounds from outside the vehicle.
- Protect this unit from moisture.
- If the battery is disconnected or discharged, the preset memory will be erased and must be reprogrammed.
- Should this unit fail to operate properly, please contact your dealer or nearest authorized PIONEER Service Station.

### DVD video disc region numbers

DVD video discs that have incompatible region numbers cannot be played on this player. The region number of the player can be found on the bottom of this unit and this manual (refer to *Specifications* on page 107). 

### About this manual

This unit features a number of sophisticated functions ensuring superior reception and operation. All the functions have been designed for the easiest possible use, but many are not self-explanatory. This operation manual will help you benefit fully from this unit's potential and to maximize your listening enjoyment. We recommend that you familiarize yourself with the functions and their operation by reading through the manual before you begin using this unit. It is especially important that

you read and observe **WARNINGs** and **CAUTIONs** in this manual. 

### Visit our website

Visit us at the following site:

<http://pioneer.jp/group/index-e.html>

- We offer the latest information about Pioneer Corporation on our website. 

### Features

#### Touch panel key operation

It is possible to operate this unit by using touch panel key.

Also, scroll bar and scrubber bar can be controlled at your fingertip.

#### DVD-R/RW compatibility

It is possible to play back DVD-R/RW discs recorded with the video format and Video Recording format. (Refer to *DVD-R/DVD-RW discs* on page 95.)

#### Video CDs featuring PBC compatibility

It is possible to play back Video CDs featuring PBC (playback control).

#### CD playback

Music CD/CD-R/RW playback is possible.

#### MP3 file playback

You can play back MP3 files recorded on CD-R/RW/ROM (ISO9660 Level 1/Level 2 standard), DVD-R/RW/ROM (ISO9660 Level 1/Level 2 standard, UDF 1.02) and USB storage device (FAT 16, FAT 32).

#### WMA file playback

You can play back WMA files recorded on CD-R/RW/ROM (ISO9660 Level 1/Level 2 standard), DVD-R/RW/ROM (ISO9660 Level 1/Level 2 standard, UDF 1.02) and USB storage device (FAT 16, FAT 32).

**AAC file playback**

You can play back AAC files recorded on CD-R/RW/ROM (ISO9660 Level 1/Level 2 standard), DVD-R/RW/ROM (ISO9660 Level 1/Level 2 standard, UDF 1.02) and USB storage device (FAT 16, FAT 32).

**DivX® video compatibility**

Refer to *DivX compatibility* on page 99.

**JPEG picture file playback**

You can play back JPEG picture files recorded on CD-R/RW/ROM and USB storage device.

**Dolby Digital/DTS compatibility**

When using this unit with a Pioneer multi-channel processor, you can enjoy the atmosphere and excitement provided by DVD movie and music software featuring 5.1 channel recordings.

**Portable audio player compatibility**

- Make inquiries to the manufacturer about your USB portable audio player/USB memory.
- This unit corresponds to the following.
- USB MSC (Mass Storage Class) compliant portable audio player and memory
  - WMA, MP3 and AAC file playback
  - JPEG file playback

**iPod compatibility**

This unit can control, listen to songs and view videos on an iPod.

For details about the supported iPod, refer to *iPod compatibility* on page 97.

**Hands-free phoning**

Using Bluetooth adapter (e.g. CD-BTB100), this unit realizes effortless hands-free phoning with Bluetooth wireless technology.

**Bluetooth audio player compatibility**

Using Bluetooth adapter (e.g. CD-BTB100), you can control Bluetooth audio player featuring Bluetooth wireless technology.

**About DivX**

DivX is a compressed digital video format created by the DivX® video codec from DivX, Inc. This unit can play DivX video files recorded on CD-R/RW/ROM and DVD-R/RW/ROM discs. Keeping the same terminology as DVD video, individual DivX video files are called "Titles". When naming files/titles on a CD-R/RW or a DVD-R/RW disc prior to burning, keep in mind that by default they will be played in alphabetical order.



Official DivX® Certified product

Plays all versions of DivX® video (including DivX® 6) with standard playback of DivX® media files. 

**When an operation is prohibited**

When you are watching a DVD and attempt to perform an operation, it may not be performed because of the programming on the disc.

When this happens, the icon  appears on the screen.

- The icon  may not appear with certain discs. 

**Resetting the microprocessor**

Pressing **RESET** lets you reset the microprocessor to its initial settings without changing the bookmark information.

The microprocessor must be reset under the following conditions:

- Prior to using this unit for the first time after installation
- If the unit fails to operate properly
- When strange or incorrect messages appear on the display

**1 Turn the ignition switch OFF.**

## Before You Start

### 2 Press RESET with a pen tip or other pointed instrument.

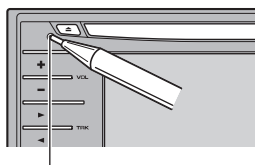

RESET button



#### Note

After completing connections or when you want to erase all memorized settings or return the unit to its initial (factory) settings, switch your engine ON or set the ignition switch to ACC ON before pressing **RESET**.

## Feature demo mode

The feature demo automatically starts when you select the source **Off**. The demo continues while the ignition switch is set to ACC or ON. To cancel the feature demo, press and hold **MUTE**. To restart the feature demo, press and hold **MUTE** again. Remember that if the feature demo continues operating when the car engine is turned off, it may drain battery power.



#### Important

The red lead (ACC) of this unit should be connected to a terminal coupled with ignition switch on/off operations. If this is not done, the vehicle battery may be drained.

## Use and care of the remote control

### Installing the battery

Slide the tray on the back of the remote control out and insert the battery with the plus (+) and minus (-) poles aligned properly.

- When using for the first time, pull out the film protruding from the tray.

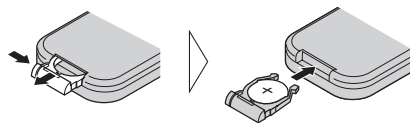

### **!** WARNING

Keep the battery out of the reach of children. Should the battery be swallowed, consult a doctor immediately.



### CAUTION

- Use one **CR2025 (3 V)** lithium battery.
- Remove the battery if the remote control is not used for a month or longer.
- There is a danger of explosion if the battery is incorrectly replaced. Replace only with the same or equivalent type.
- Do not handle the battery with metallic tools.
- Do not store the battery with metallic objects.
- If the battery leaks, wipe the remote control completely clean and install a new battery.
- When disposing of used batteries, comply with governmental regulations or environmental public institutions' rules that apply in your country/area.

### Using the remote control

Point the remote control in the direction of the front panel to operate.

- The remote control may not function properly in direct sunlight.



#### Important

- Do not store the remote control in high temperatures or direct sunlight.
- Do not let the remote control fall onto the floor, where it may become jammed under the brake or accelerator pedal.

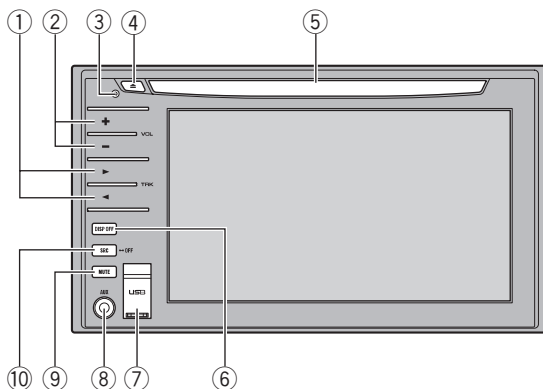

## Head unit

### ① ◀/▶ (TRK) buttons

Press to do manual seek tuning, fast forward, reverse and track search controls.

### ② +/- (VOL) buttons

Press to increase or decrease the volume.

### ③ RESET button

Press to return to the factory settings (initial settings).

### ④ ▲ (eject) button

Press to eject a disc from this unit.

### ⑤ Disc loading slot

Insert a disc to play.

### ⑥ DISP OFF button

Press to turn the information display on or off.

### ⑦ USB port

Use to connect a USB storage device.

- When connecting, open up the USB connector lid.
- Use a USB cable to connect the USB storage device to the USB port. Since the USB storage device is projected forward from the unit, it is dangerous to connect directly.

Pioneer CD-U50E USB cable is also available. For details, consult your dealer.

### ⑧ AUX1 input jack (3.5 mm stereo/video jack)

Use to connect an auxiliary device.

### ⑨ MUTE button

Press to turn off the sound. To turn on the sound, press again.

### ⑩ SRC/OFF button

Press to cycle through all the available sources. Press and hold to turn the source off. 

# What's what

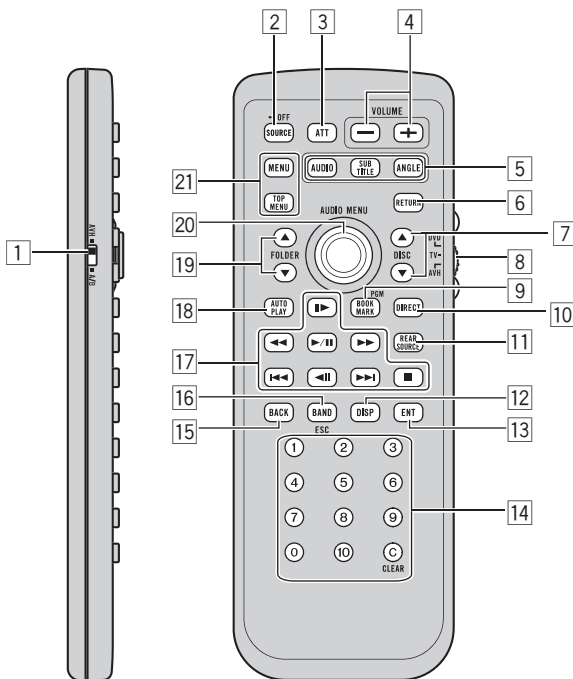

## Remote control

	Button names	AVH mode	DVD mode
1	Remote control selection switch	Switch to change the setting of the remote control. For details, refer to <i>Setting remote control code type</i> on page 62.	
2	<b>SRC/OFF</b> button	Press to cycle through all the available sources. Press and hold to turn the source off.	
3	<b>ATT</b> button	Press to quickly lower the volume level by about 90%. Press once more to return to the original volume level.	
4	<b>VOLUME</b> buttons	Press to increase or decrease the volume.	
5	<b>AUDIO</b> button	Press to change the audio language during DVD playback while using the built-in DVD player.	
	<b>SUBTITLE</b> button	Press to change the subtitle language during DVD playback while using the built-in DVD player.	
	<b>ANGLE</b> button	Press to change the viewing angle during DVD playback while using the built-in DVD player.	
6	<b>RETURN</b> button	Press to display the PBC (playback control) menu during PBC playback.	

## What's what

7	▲/▼ buttons (DISC)	Not used.	<b>Remote control code: AVH or B</b> Not used. <b>Remote control code: A</b> Press to select the next/previous disc.
8	Remote control operation mode switch	Switch the operation mode between <b>AVH</b> , <b>DVD</b> and <b>TV</b> modes. Normally, set to <b>AVH</b> . For details, refer to <i>Using the remote control operation mode switch</i> on the next page.	
9	<b>Bookmark</b> button/ <b>PGM</b> button	Press to operate the preprogrammed functions for each source. (Refer to <i>Using the PGM button</i> on page 64.)	Press to turn the bookmark function on or off when your DVD player features bookmark function. For details, refer to DVD player's operation manual.
10	<b>DIRECT</b> button	Not used.	
11	<b>REAR SOURCE</b> button	Not used.	<b>Remote control code: AVH</b> Not used. <b>Remote control code: A or B</b> Press to turn the DVD player on or off.
12	<b>DISPLAY</b> button	Press to select different displays.	<b>Remote control code: AVH</b> Not used. <b>Remote control code: A or B</b> Press to select different displays.
13	<b>ENTERTAINMENT</b> button	Not used.	
14	<b>0 to 10</b> buttons, <b>CLEAR</b> button	Press <b>0 to 10</b> to input numbers. Buttons <b>1 to 6</b> can operate the preset tuning for the tuner or disc changing for DVD player or multi-CD player. Press <b>CLEAR</b> to clear the input numbers.	Press to select a menu item on a video CD featuring PBC (playback control).
15	<b>Back</b> button	Press to return to the previous display.	Not used.
16	<b>BAND/ESC</b> button	Press to select the tuner band when tuner is selected as a source. Also used to cancel the control mode of functions. Press to switch mode between compressed audio and audio data (CD-DA) when playing discs with compressed audio and audio data (CD-DA) such as CD-EXTRA and MIXED-MODE CDs.	Press to switch mode between compressed audio and audio data (CD-DA) when playing discs with compressed audio and audio data (CD-DA) such as CD-EXTRA and MIXED-MODE CDs.
17	<b>PLAY/PAUSE</b> (▶/II) button	Press to switch sequentially between playback and pause while using the built-in DVD player.	
	<b>REVERSE</b> (◀◀) button	Press to perform fast reverse while using the built-in DVD player.	
	<b>FORWARD</b> (▶▶) button	Press to perform fast forward while using the built-in DVD player.	
	<b>PREVIOUS</b> (I◀◀) button	Press to return to the previous track (chapter) while using the built-in DVD player.	
	<b>NEXT</b> (▶▶I) button	Press to go to the next track (chapter) while using the built-in DVD player.	
	<b>STEP</b> (II▶/◀II) buttons	Press to move ahead one frame at a time during DVD/VideoCD playback. Press and hold for one second to activate slow playback while using the built-in DVD player.	
	<b>STOP</b> (■) button	Press to stop playback while using the built-in DVD player.	

## What's what

18	<b>AUTO PLAY</b> button	Press to turn the DVD auto-playback function on or off while using the built-in DVD player.	
19	<b>▲/▼</b> buttons ( <b>FOLDER</b> )	Press to select the next/previous folder.	
20	Thumb pad	Move to do fast forward, reverse and track search controls. Click to recall <b>Menu</b> .	Move to select a menu on the DVD menu.
21	<b>MENU</b> button	Press to display the DVD menu during DVD playback.	
	<b>TOP MENU</b> button	Press to return to the top menu during DVD playback.	

### Using the remote control operation mode switch

There are three remote control operation modes on the remote control.

#### AVH mode operation

When operating this unit by remote control, the mode is normally switched to **AVH**.

#### DVD mode operation

If you switch the mode to **DVD**, the thumb pad and **0** to **10** operations are changed for the DVD player.

- **When you want to operate the following functions, switch the mode to DVD:**

- When operating the DVD menu by using the thumb pad. (Refer to *Operating the DVD menu* on page 22.)
- When operating the PBC menu by using **0** to **10**. (Refer to *PBC playback* on page 27.)

#### TV mode operation

TV operations available with a Pioneer TV tuner (e.g. GEX-P5750TV(P)) can be controlled with **AVH** mode. **TV** mode is not used with this unit.

- For details concerning operation, refer to the TV tuner's operation manuals. 

## Power ON/OFF



① Source icon

### Turning the unit on

- **When using the touch panel keys, touch the source icon and then touch the desired source name.**

The source names are displayed and selectable ones are highlighted.

- **When using the button, press SRC/OFF to turn the unit on.**

### Turning the unit off

- **When using the touch panel keys, touch the source icon and then touch Off.**
  - When the source icon is not displayed, you can display it by touching the screen.
- **When using the button, press SRC/OFF and hold until the unit turns off.** 

## Selecting a source

You can select a source you want to listen to. To switch to the DVD player, load a disc in the unit.

- **When using the touch panel keys, touch the source icon and then touch the desired source name.**

The source names are displayed and selectable ones are highlighted.

- **Disc** – Built-in DVD player
- **Radio** – Radio

- **M-CD** – Multi-CD player
- **TV** – Television
- **AV** – AV input
- **EXT-1** – External unit 1
- **EXT-2** – External unit 2
- **AUX-1** – AUX 1
- **AUX-2** – AUX 2
- **USB/iPod** – USB/iPod
- **TEL** – Bluetooth telephone
- **BT Audio** – Bluetooth audio player
- **RearView** – Rear view camera
- **Off** – Turn the unit off

- When the source icon is not displayed, you can display it by touching the screen.
  - While operating the menu, you cannot select a source by touching the source icon.
  - To close source select menu, touch **ESC**.

- **When using the button, press SRC/OFF repeatedly to select a desired source.**

### Notes

- In the following cases, the sound source will not change.
  - When no unit corresponding to the selected source is connected.
  - When there is no disc or magazine in the player.
  - When AUX (auxiliary input) is set to off (refer to page 53).
  - When the AV (AV input) is not set to **Video** (refer to page 58).
- In the following cases, **USB/iPod** icon will be changed.
  - **USB** is displayed when USB storage device is connected.
  - **iPod** is displayed when iPod is connected.
  - **USB/iPod** is displayed when no device is connected.
- AUX1 is set to **Video** by default. Set the AUX1 to **Off** when not in use (refer to *Switching the auxiliary setting* on page 53).
- Charging the portable audio player using car's DC power source while connecting it to AUX input may generate noise. In this case, stop charging.

## Basic Operations

- **RearView** (rear view camera) cannot be selected by pressing **SRC/OFF**.
- Image from rear view camera can be displayed automatically when the appropriate setting is conducted. For details, refer to *Setting for rear view camera (back up camera)* on page 59.
- External unit refers to a Pioneer product (such as ones available in the future) that, although incompatible as a source, enables control of basic functions with this unit. Two external units can be controlled with this unit. When two external units are connected, the external unit is automatically allocated to external unit 1 or external unit 2 by this unit.
- When this unit's blue/white lead is connected to the vehicle's auto-antenna relay control terminal, the vehicle's antenna extends when this unit's source is turned on. To retract the antenna, turn the source off.

## Adjusting the volume

- Press **+** or **-** to adjust the sound level.

## Touch panel key basic operation

### Activating the touch panel keys

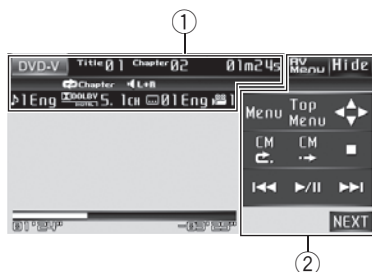

- ① **Information area**  
Shows the various information depending on the source.

- ② **Touch panel keys**  
Touch to do various operations.

#### 1 Touch the screen to activate the touch panel keys corresponding to each source.

The touch panel keys appear on the display.

- To go to the next group of touch panel keys, touch **NEXT**.
- To return to the previous group of touch panel keys, touch **PREV**.

#### 2 Touch Hide to hide the touch panel keys.

- If you do not use the touch panel keys within 30 seconds, they will be hidden automatically when selecting video sources.

## Operating the menu

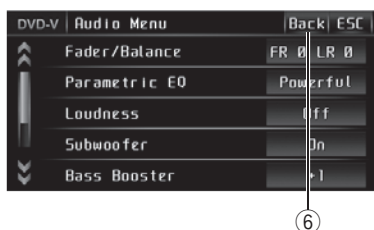
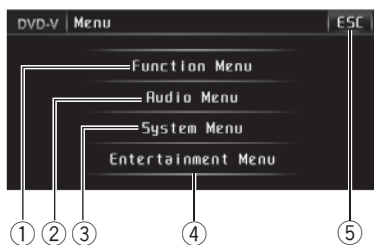

- ① **Function Menu key**  
Touch to switch to the functions for each source.
- ② **Audio Menu key**  
Touch to switch to the sound quality control menu.
- ③ **System Menu key**  
Touch to switch to the setup functions menu.
- ④ **Entertainment Menu key**  
Touch to switch to the entertainment setup menu.
- ⑤ **ESC key**  
Touch to cancel the control mode of functions.
- ⑥ **Back key**  
Touch to return to the previous display.

### 1 Touch AV Menu to display Menu.

The menu names are displayed and operable ones are highlighted.

- When **AV Menu** is not displayed, you can display it by touching the screen.

**2 Touch the desired key to display the function names you want to operate.**

**3 Touch ESC to return to the display of each source.**

## Operating the scroll bar and the scrubber bar

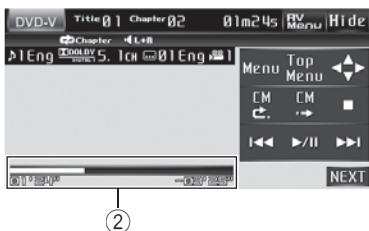

- ① **Scroll bar**
- ② **Scrubber bar**



This unit features touch operation of scroll bar and scrubber bar.

If the menu has multiple pages or list has more than five selections, you can drag the scroll bar on the left side of the menu to view the hidden objects. For the disc and USB storage device operation, you can specify the playback point by dragging the scrubber bar.

## Basic Operations

### Scroll bar operation

● If you see the scroll bar on the left side of the screen, drag upward or downward to view the hidden object.

- Touching  or  can also display the hidden object.

### Scrubber bar operation

This operation is available for the following sources:

- DVD-video, DVD-VR
- Video CD
- CD
- Compressed audio files (disc/USB)
- DivX

● Drag the scrubber bar on the screen to specify the playback point.

- Drag operation is not available when the scrubber bar is grayout. 

## Built-in DVD player basic operations

### Playing a disc

● Insert a DVD (-R/-RW), CD (-R/-RW) into the disc loading slot.

Playback will automatically start.

- **Be sure to turn up the label side of a DVD (-R/-RW), CD (-R/-RW).**
- After a DVD (-R/-RW), CD (-R/-RW) has been inserted, use touch panel keys to select the DVD player.
- When a DVD (-R/-RW), CD (-R/-RW) is loaded in this unit, touch the source icon and then touch **Disc** to select **Disc**.
- If you are playing a DVD or Video CD, a menu may appear. Refer to *Operating the DVD menu* on page 22 and *PBC playback* on page 27.

▪ When the automatic playback function is on, this unit will cancel the DVD menu and automatically start playback from the first chapter of the first title. Refer to *Automatic playback of DVDs* on page 25.



- To eject a DVD (-R/-RW), CD (-R/-RW), press  (eject).

### Notes

- The DVD player plays one, standard, 12-cm DVD (-R/-RW), CD (-R/-RW) at a time. Playing back an 8-cm disc is not possible with this unit.
- Do not insert anything other than a DVD (-R/-RW), CD (-R/-RW) into the disc loading slot.
- If bookmark function is on, DVD playback resumes from the selected point. For more details, refer to *Resume playback (Bookmark)* on page 23.
- If a DVD (-R/-RW), CD (-R/-RW) contains a mixture of various media file types such as DivX and MP3, you can switch between media file types to play. Refer to *Switching the media file type* on the next page.
- If you cannot insert a disc completely or if after you insert a disc the disc does not play, check that the label side of the disc is up. Press  to eject the disc, and check the disc for damage before inserting it again.
- There is sometimes a delay between starting up disc playback and the sound being issued. When being read, **Format Read** is displayed.
- If an error message is displayed, refer to *Error messages* on page 90.

## Basic playback controls

The table below shows the basic controls for playing discs. The following chapters cover other playback features in more details.

Key	What it does
	Starts playback, pauses a disc that's playing or restarts a paused disc.
	Stops playback.

- 
- Skips to the start of the current track, chapter or file, then to previous tracks/chapters/files.
- ◀◀
- Performs fast reverse by touching and holding ▶▶.
- 

- Skips to the next track, chapter or file.
- ▶▶
- Performs fast forward by touching and holding ▶▶.
- 

**Note**

You may find with some DVD or Video CD discs that some playback controls do not work in certain parts of the disc. This is not a malfunction.

## Switching the media file type

When playing a disc containing a mixture of various media file types such as DivX and MP3, you can switch between media file types to play.

- This unit allows playback of the following media file type recorded on CD-R/RW/ROM discs.
  - Audio data (CD-DA)
  - Compressed audio files
  - DivX video files
  - JPEG picture files
- In case of DVD-R/RW/ROM, this unit does not allow playback of audio data (CD-DA) or JPEG picture files.

### ● Touch Media to switch between media file types.

Touch **Media** repeatedly to switch between the following media file types:

**CD** (audio data (CD-DA))—**ROM-Audio** (compressed audio)—**DivX** (DivX video files)—**JPEG** (JPEG picture files) 

# Radio

## Listening to the radio



### Important

If you are using this unit in North, Central or South America, reset the AM tuning step (refer to *Setting the AM tuning step* on page 53).

These are the basic steps necessary to operate the radio. More advanced tuner operation is explained starting in the following section. Refer to the next page.

#### ① Source icon

Shows which source has been selected.

#### ② Band indicator

Shows which band the radio is tuned to, AM or FM.

#### ③ Preset number indicator

Shows which preset has been selected.

#### ④ Frequency indicator

Shows the frequency to which the tuner is tuned.

#### ⑤ LOCAL indicator

Appears when local seek tuning is on.

#### ⑥ (stereo) indicator

Appears when the selected frequency is being broadcast in stereo.

### 1 Touch the source icon and then touch Radio to select the radio.

### 2 Touch Band to select a band.

Touch **Band** until the desired band (**FM1**, **FM2**, **FM3** for FM or **AM**) is displayed.

### 3 To perform manual tuning, briefly touch ◀ or ▶.

- You can also perform manual tuning by pressing ◀ or ▶ (**TRK**).

### 4 To perform seek tuning, keep touching ◀ or ▶ for about one second and release.

The tuner will scan the frequencies until a broadcast strong enough for good reception is found.

- You can cancel seek tuning by briefly touching either ◀ or ▶.
- If you keep touching ◀ or ▶ you can skip stations. Seek tuning starts as soon as you release the key.
- You can also perform seek tuning by pressing and holding ◀ or ▶ (**TRK**).



### Note

Listening AM radio while an iPod is charged from this unit may generate noise. In this case, disconnect the iPod from this unit. □

## Storing and recalling broadcast frequencies

You can easily store up to six broadcast frequencies for later recall.

- Six stations for each band can be stored in memory.

### 1 Touch List to display the preset list.

### 2 When you find a frequency that you want to store in memory keep touching one of preset tuning keys P1 to P6 until the beep sounds.

The selected radio station frequency has been stored in memory.

The next time you touch the same preset tuning key the radio station frequency is recalled from memory.

- When **P1** to **P6** are not displayed, you can display them by touching **List**.
- You can also use ▲ and ▼ to recall radio station frequencies assigned to preset tuning keys **P1** to **P6**.

3 Touch **ESC** to return to the ordinary display. 

## Introduction of advanced tuner operation

1 Touch **AV Menu** and then touch **Function Menu** to display the function names.

The function names are displayed and operable ones are highlighted.

2 Touch **ESC** to return to the frequency display.

- To return to the previous display, touch **Back**. 

## Storing the strongest broadcast frequencies

BSM (best stations memory) automatically stores the six strongest broadcast frequencies in the order of their signal strength.

- Storing broadcast frequencies with BSM may replace broadcast frequencies you have saved using **P1** to **P6**.

● Touch **BSM** on the function menu to turn **BSM** on.

**BSM** begins to flash. While **BSM** is flashing the six strongest broadcast frequencies will be stored under preset tuning keys **P1** to **P6** in order of their signal strength. When finished, **BSM** stops flashing.

- To cancel the storage process, touch **BSM** again. 

## Tuning in strong signals

Local seek tuning lets you tune in only those radio stations with sufficiently strong signals for good reception.

● Touch **Local** on the function menu to set the sensitivity.

Touch **Local** repeatedly until the desired level of sensitivity appears in the display.

There are four levels of sensitivity for FM and two levels for AM:

FM: **Off—Level1—Level2—Level3—Level4**

AM: **Off—Level1—Level2**

Larger setting number is higher level. The highest level setting allows reception of only the strongest stations, while lower settings let you receive progressively weaker stations. 

# Playing DVD discs

## Watching a DVD

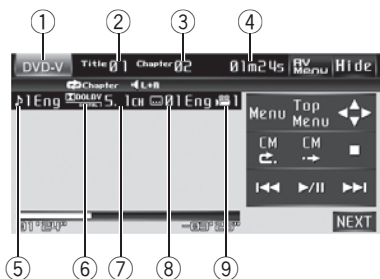

DVD video

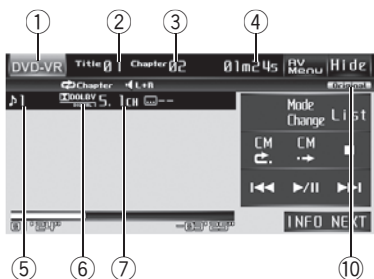

DVD-VR

These are the basic steps necessary to play a DVD with your DVD player. More advanced DVD operation is explained starting in the following section. Refer to page 25.

- ① **Source icon**  
Shows which source has been selected.
- ② **Title number indicator**  
Shows the title currently playing.
- ③ **Chapter number indicator**  
Shows the chapter currently playing.
- ④ **Play time indicator**  
Shows the elapsed playing time of the current chapter.

- ⑤ **Audio language indicator**  
Shows which audio language has been selected.  
For DVD-VR, only the number of the audio language is displayed.
- ⑥ **Digital format indicator**  
Shows when a signal encoded in the corresponding format is detected.
- ⑦ **Channel/sampling frequency/quantization bits**  
Depending on the file format, some information may not be displayed.
- ⑧ **Subtitle language indicator**  
Shows which subtitle language has been selected.
- ⑨ **Viewing angle indicator**  
Shows which viewing angle has been selected.
- ⑩ **Playing method indicator**  
Shows which playing method (**Original** or **Playlists**) has been selected.

### 1 Touch the source icon and then touch Disc to select the DVD player.

- If no disc is loaded in the unit, you cannot select **Disc** (DVD player). Insert a disc in the unit. (Refer to page 17.)
- With some discs, a menu may be displayed. (Refer to *Operating the DVD menu* on the next page.)

### 2 Touch the screen to display the touch panel keys.

- Touch **Hide** to hide the touch panel keys.

### 3 To skip back or forward to another chapter, touch I◀◀ or ▶▶I.

Touching ▶▶I skips to the start of the next chapter. Touching I◀◀ once skips to the start of the current chapter. Touching it again will skip to the previous chapter.

- You can also skip back or forward to another chapter by pressing ◀ or ▶ (TRK).

#### 4 To perform fast forward or reverse, keep touching I◀◀ or ▶▶I.

If you keep touching I◀◀ or ▶▶I for five seconds, the icon ◀◀ or ▶▶ is highlighted.

When this happens, fast reverse/fast forward continues even if you release I◀◀ or ▶▶I. To resume playback at a desired point, touch ▶/II.

- Fast forward/fast reverse may not be possible at certain locations on some discs. If this happens, normal playback automatically resumes.
- You can also perform fast reverse/fast forward by pressing and holding ◀ or ▶ (TRK). ◻

## Selecting titles from the title list

Title list lets you see the list of titles on a disc and select one of them to play back.

- This function is available for DVD-VR.

### 1 Touch List.

### 2 Touch your favorite title.

That selection will begin to play.

### 3 Touch ESC to return to the ordinary display. ◻

## Displaying information of DVD-VR

Information of DVD-VR can be displayed.

- This function is available for DVD-VR.

#### ● Touch INFO.

Touch **INFO** repeatedly to switch between the following settings:

Indicators—title name

- If specific information has not been recorded on a DVD-VR disc, **No xxxx** will be displayed (e.g., **No Title**).
- If the characters recorded on the disc are not compatible with this unit, those characters will not be displayed. ◻

## Skipping back or forward to another title

#### ● To skip back or forward to another title, touch ▲ or ▼.

Touching ▲ skips to the start of the next title.

Touching ▼ skips to the start of the previous title.

Title numbers are displayed for eight seconds. ◻

## Operating the DVD menu

Some DVDs allow you to select from the disc contents using a menu.

- This function is available for DVD video.
- You can display the menu by touching **Menu** or **Top Menu** while a disc is playing. Touching either of these keys again lets you start playback from the location selected from the menu. For details, refer to the instructions provided with the disc.

## Using DVD menu direct touch control

This function allows you to operate the DVD menu by touching the menu item directly.

#### ● Touch the desired menu item on the DVD menu directly.

- Depending on the contents of DVD discs, this function may not work properly. In this case, using touch panel keys operate the DVD menu.

## Using the touch panel keys

### 1 Touch ◀↔▶ to display touch panel keys to operate the DVD menu.

- When the touch panel keys are not displayed, you can display them by touching the screen.
- To switch to the DVD menu direct touch control, touch **Touch**.

### 2 Touch ▲, ▼, ◀ or ▶ to select the desired menu item.

## Playing DVD discs

### 3 Touch ↵.

Playback starts from the selected menu item.

- The way to display the menu differs depending on the disc.

## Selecting the play mode

You have two methods for playing DVD-VR disc; **Original** (original) and **Playlists** (playlist).

- Titles created with DVD recorders are called original. Based on original, rearranged titles are called playlist. Playlists are created on DVD-R/RW discs.
- This function is available for DVD-VR.
- **Touch Mode Change to switch the play mode.**

If the play mode is changed, playback starts from the beginning of the selected play mode.

## Resume playback (Bookmark)

The Bookmark function lets you resume playback from a selected scene the next time the disc is loaded.

- This function is available for DVD video.

### ● During playback, touch **Bookmark** at the point you want to resume playback next time.

The selected scene will be bookmarked so that playback resumes from that point next time.

- To clear the bookmark on a disc, keep touching **Bookmark** during playback.
- You can also bookmark a disc by pressing and holding at the point you want to bookmark. Next time you load the disc, playback will resume from the bookmarked point. Note that you can only bookmark one disc using this method. To clear the bookmark on a disc, press .
- You can bookmark up to six discs including the disc that is bookmarked using .
- The oldest bookmark is replaced by the new one.

## CM skip/CM back

This function skips a reproduced image for a specified time. If the currently playing disc contains commercials, it is possible to skip them.

### ● To skip progressively backward or forward, touch or .

Each time you touch or it changes steps in the following order:

#### CM back

5 sec.—15 sec.—30 sec.—1.0 min.—2.0 min.—3.0 min.—0 sec.

#### CM skip

30 sec.—1.0 min.—1.5 min.—2.0 min.—3.0 min.—5.0 min.—10.0 min.—0 sec.

## Frame-by-frame playback

This lets you move ahead one frame at a time during playback.

### ● Touch during playback.

Each time you touch , you move ahead one frame.

- To return to normal playback, touch /||.
- With some discs, images may be unclear during frame-by-frame playback.
- If a DVD-VR disc contains a still image, touch while displaying a still image to switch to the next image or video.

## Slow motion playback

This lets you slow down playback speed.

### ● Keep touching until is displayed during playback.

The icon is displayed, forward slow motion playback begins.

- Touching or during slow motion playback, you can change the playback speed in four steps as follows:  
1/16—1/8—1/4—1/2
- To return to normal playback, touch /||.

### Notes

- There is no sound during slow motion playback.
- With some discs, images may be unclear during slow motion playback.
- Reverse slow motion playback is not possible. 

## Pausing playback

- **Touch ►/II during playback.**
  - To resume playback at the same point that you turned pause on, touch ►/II again. 

## Searching for the part you want to play

You can use the search function to find the part you want to play.

For DVD video, you can select **Title** (title), **Chapter** (chapter), **Time** (time) or **10key** (numeric keypad).

For DVD-VR, you can select **Title** (title), **Chapter** (chapter) or **Time** (time).

- Chapter search and time search are not possible when disc playback has been stopped.

- 1 Touch Search.**
- 2 Touch the desired search option (e.g., Chapter).**
- 3 Touch 0 to 9 to input the desired number.**
  - To cancel the inputted numbers, touch **C**.
  - In the time search function, to select 1 hour 11 minutes, convert the time into 071 minutes 00 seconds and touch **0**, **7**, **1**, **0** and **0** in that order.
- 4 Touch ↵.**  
This starts playback from the selected part.

### Note

With discs featuring a menu, you can also touch **Menu** or **Top Menu** and then make selections from the displayed menu. 

## Changing audio language during playback (Multi-audio)

DVDs can provide audio playback with different languages and different systems (Dolby Digital, DTS etc.). With DVDs featuring multi-audio recordings, you can switch between languages/audio systems during playback.

- **Touch Audio during playback.**  
Each time you touch **Audio** it switches between audio systems.

### Notes

- With some DVDs, switching between languages/audio systems may only be possible using a menu display.
- You can also switch between languages/audio systems using **Setup**. For details, refer to *Setting the audio language* on page 49.
- Only digital output of DTS audio is possible. If this unit's optical digital outputs are not connected, DTS audio will not be output, so select an audio setting other than DTS.
- Display indications such as **Dolby D** and **5.1ch** indicate the audio system recorded on the DVD. Depending on the setting, playback may not be with the same audio system as that indicated.
- Touching **Audio** during fast forward/fast reverse, pause or slow motion playback returns you to normal playback. 

## Playing DVD discs

### Changing the subtitle language during playback (Multi-subtitle)

With DVDs featuring multi-subtitle recordings, you can switch between subtitle languages during playback.

#### ● Touch Subtitle during playback.

Each time you touch **Subtitle** it switches between subtitle languages.

#### Notes

- With some DVDs, switching between subtitle languages may only be possible using a menu display.
- You can also switch between subtitle languages using **Setup**. For details, refer to *Setting the subtitle language* on page 49.
- Touching **Subtitle** during fast forward/fast reverse, pause or slow motion playback returns you to normal playback. 

### Changing the viewing angle during playback (Multi-angle)

With DVDs featuring multi-angle (scenes shot from multiple angles) recordings, you can switch among viewing angles during playback.

- This function is available for DVD video.
- During playback of a scene shot from multiple angles, the angle icon  is displayed. Turn angle icon display on or off using **Setup**. For details, refer to *Setting the angle icon display* on page 50.

#### ● Touch Angle during playback of a scene shot from multiple angles.

#### Note

Touching **Angle** during fast forward/fast reverse, pause or slow motion playback returns you to normal playback. 

### Return to the specified scene

You can return to the specified scene where the DVD you are currently playing has been preprogrammed to return.

- This function is available for DVD video.

#### ● Touch Return to return to the specified scene.

- If a specified scene has not been preprogrammed in DVD disc, this function is not possible. 

### Automatic playback of DVDs

When a DVD disc with DVD menu is inserted, this unit will cancel the DVD menu automatically and start playback from the first chapter of the first title.

- This function is available for DVD video.
- Some DVDs may not operate properly. If this function is not fully operated, turn this function off and start playback.

#### ● Touch Auto Play to turn automatic playback on.

- To turn automatic playback off, touch **Auto Play** again.
- When the automatic playback is on, you cannot operate repeating play of DVD disc (refer to *Repeating play* on the next page). 

### Introduction of advanced DVD operation

#### 1 Touch AV Menu and then touch Function Menu to display the function names.

The function names are displayed and operable ones are highlighted.

#### 2 Touch ESC to return to the playback display.

- To return to the previous display, touch **Back**. 

## Repeating play

There are three repeat play ranges for DVD playback.

- **Touch Repeat on the function menu to select the repeat range.**

- **Disc** – Play through the current disc
- **Chapter** – Repeat the current chapter
- **Title** – Repeat the current title
- If you perform chapter search or fast forward/reverse, the repeat play range changes to **Disc**. 

## Selecting audio output

When playing DVD video discs recorded with LPCM audio, you can switch the audio output.

- This function is not possible when disc playback has been stopped.
- If you select **Linear PCM**, when playing a disc recorded on a dual mono mode, you can operate this function. (Refer to *Setting for digital output* on page 52.)

- **Touch L/R Select on the function menu to select the audio output.**

Touch **L/R Select** repeatedly until the desired audio output appears in the display.

- **L+R** – left and right
- **Left** – left
- **Right** – right
- **Mix** – mixing left and right
- Depending on the disc and the playback location on the disc, the function may not be selectable, indicating that operating this function is not possible. 

## Playing Video CDs

### Watching a Video CD

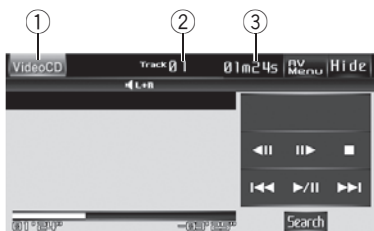

These are the basic steps necessary to play a Video CD with your DVD player. More advanced Video CD operation is explained starting in the following section. Refer to the next page.

#### ① Source icon

Shows which source has been selected.

#### ② Track number indicator

Shows the number of the track playing.

#### ③ Play time indicator

Shows the elapsed playing time of the current track.

### 1 Touch the source icon and then touch Disc to select the DVD player.

- If no disc is loaded in the unit, you cannot select **Disc** (DVD player). Insert a disc in the unit. (Refer to page 17.)

- With a Video CD featuring the PBC (playback control) function, a menu is displayed. (Refer to *PBC playback* on this page.)

### 2 Touch the screen to display the touch panel keys.

- Touch **Hide** to hide the touch panel keys.

### 3 To skip back or forward to another track, briefly touch I◀◀ or ▶▶I.

Touching ▶▶I skips to the start of the next track. Touching I◀◀ once skips to the start of the current track. Touching it again will skip to the previous track.

- During PBC playback, a menu may be displayed if you perform these operations.
- You can also skip back or forward to another track by pressing ◀ or ▶ (TRK).

### 4 To perform fast forward or reverse, keep touching I◀◀ or ▶▶I.

If you keep touching I◀◀ or ▶▶I for five seconds, the icon I◀◀ or ▶▶I is highlighted.

When this happens, fast reverse/fast forward continues even if you release I◀◀ or ▶▶I. To resume playback at a desired point, touch ▶/II.

- Fast forward/fast reverse may not be possible at certain locations on some discs. If this happens, normal playback automatically resumes.
- You can also perform fast reverse/fast forward by pressing and holding ◀ or ▶ (TRK). ◻

## PBC playback

During playback of Video CDs featuring PBC (Playback Control), **PBC ON** is displayed. You can operate PBC menu with **10Key**.

### 1 When PBC menu is displayed, touch Search and then touch 10key.

- Depending on the discs, the menu may be two or more pages long. In such case, touch I◀◀ or ▶▶I to display the next or previous menu.

### 2 Touch 0 to 9 corresponding to a menu number and then touch ↵ to start playback.

Playback starts from the selected menu item.

### 3 Touch ESC to hide the touch panel keys.

#### Notes

- You can display the menu by touching **Return** during PBC playback. For details, refer to the instructions provided with the disc.
- PBC playback of Video CD cannot be canceled.

- During playback of Video CDs featuring PBC (Playback Control), **PBC ON**, search and time search functions cannot be used nor can you select the range for repeat play. 

## Frame-by-frame playback

This lets you move ahead one frame at a time during playback.

### ● Touch **II▶** during playback.

Each time you touch **II▶**, you move ahead one frame.

- To return to normal playback, touch **▶/II**.
- With some discs, images may be unclear during frame-by-frame playback. 

## Slow motion playback

This lets you slow down playback speed.

### ● Keep touching **II▶** until **⏮** is displayed during playback.

The icon **⏮** is displayed, forward slow motion playback begins.

- Touching **◀II** or **II▶** during slow motion playback, you can change the playback speed in four steps as follows:

1/16—1/8—1/4—1/2

- To return to normal playback, touch **▶/II**.



### Notes

- There is no sound during slow motion playback.
- With some discs, images may be unclear during slow motion playback.
- Reverse slow motion playback is not possible. 

## Pausing playback

### ● Touch **▶/II** during playback.

- To resume playback at the same point that you turned pause on, touch **▶/II** again. 

## Searching for a desired scene, starting playback from a specified time

You can use the search function to search for a desired scene by specifying a track, and the time search function to specify the time on a disc at which play starts.

- During playback of Video CDs featuring PBC (playback control), this function cannot be operated.
- Time search is not possible when disc playback has been stopped.

### 1 Touch Search.

### 2 Touch Track (track), Time (time) or 10key (numeric keypad).

### 3 Touch 0 to 9 to input the desired number.

- To cancel the inputted numbers, touch **C**.
- In the time search function, to select 1 hour 11 minutes, convert the time into 071 minutes 00 seconds and touch **0**, **7**, **1**, **0** and **0** in that order.

### 4 Touch **↵**.

This starts playback from the selected scene. 

## Introduction of advanced Video CD operation

### 1 Touch AV Menu and then touch Function Menu to display the function names.

The function names are displayed and operable ones are highlighted.

### 2 Touch ESC to return to the playback display.

- To return to the previous display, touch **Back**. 

## Playing Video CDs

### Repeating play

There are two repeat play ranges for the Video CD playback: **Track** (track repeat) and **Disc** (disc repeat).

- During playback of Video CDs featuring PBC (playback control), this function cannot be operated.
- **Touch Repeat on the function menu to select the repeat range.**
  - **Disc** – Repeat the current disc
  - **Track** – Repeat the current track
  - If you perform track search or fast forward/reverse, the repeat play range changes to **Disc**.

### Selecting audio output

You can switch between stereo and monaural audio output.

- This function is not possible when disc playback has been stopped.
- **Touch L/R Select on the function menu to select the audio output.**

Touch **L/R Select** repeatedly until the desired audio output appears in the display.

  - **L+R** – left and right
  - **Left** – left
  - **Right** – right
  - **Mix** – mixing left and right

## Listening to a CD

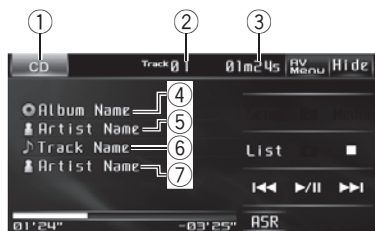

These are the basic steps necessary to play a CD with your DVD player. More advanced CD operation is explained starting in the following section. Refer to the next page.

- ① **Source icon**  
Shows which source has been selected.
- ② **Track number indicator**  
Shows the number of the track playing.
- ③ **Play time indicator**  
Shows the elapsed playing time of the current track.
- ④ **Disc title indicator**  
Shows the title of the currently playing disc only when playing CD TEXT discs.
- ⑤ **Disc artist name indicator**  
Shows the artist name of the currently playing disc only when playing CD TEXT disc.
- ⑥ **Track name list display**  
Shows the track name list only when playing CD TEXT disc.
- ⑦ **Track artist name indicator**  
Shows the artist name of the currently playing track only when playing CD TEXT disc.

### 1 Touch the source icon and then touch Disc to select the DVD player.

- Touch **Hide** to hide the touch panel keys.
- If no disc is loaded in the unit, you cannot select **Disc** (DVD player). Insert a disc in the unit. (Refer to page 17.)

### 2 To skip back or forward to another track, briefly touch I<< or >>I.

Touching >>I skips to the start of the next track. Touching I<< once skips to the start of the current track. Touching it again will skip to the previous track.

- You can also skip back or forward to another track by pressing ◀ or ▶ (TRK).

### 3 To perform fast forward or reverse, keep touching I<< or >>I.

- You can also perform fast reverse/fast forward by pressing and holding ◀ or ▶ (TRK).



#### Note

If specific information has not been recorded on a CD TEXT disc, **No xxxx** will be displayed (e.g., **No Name**). ◻

## Selecting tracks from the track title list

Track title list lets you see the list of tracks on a disc and select one of them to play back. When playing a CD TEXT disc, track titles are displayed.

### 1 Touch List.

### 2 Touch your favorite track title.

That selection will begin to play.

### 3 Touch ESC to return to the ordinary display. ◻

## Pausing playback

### ● Touch >>II during playback.

- To resume playback at the same point that you turned pause on, touch >>II again. ◻

## Playing CDs

### Switching the media file type

If a disc contains a mixture of various media file types such as DivX and MP3, you can switch between media file types to play. Refer to *Switching the media file type* on page 18.

- **Touch Media to switch between media file types.** 

### Using advanced sound retriever

Advanced sound retriever function automatically enhances compressed audio and restores rich sound.

- **Touch ASR repeatedly to select the desired setting.**

**Off** (off)—**ASR1**—**ASR2**

- **ASR2** is more effective than **ASR1**.



#### Note

When you use this unit with a multi-channel processor (DEQ-P7650/DEQ-P6600) and switch the advanced sound retriever function to **ASR1** or **ASR2**, the volume will become slightly lower. The volume will become much lower for **ASR2** than it will for **ASR1**. Take care when you increase the volume for **ASR2** and then switch to **Off**, because the volume will suddenly seem much louder. 

### Introduction of advanced CD operation

- 1 Touch AV Menu and then touch Function Menu to display the function names.**

The function names are displayed and operable ones are highlighted.

- 2 Touch ESC to return to the playback display.**

- To return to the previous display, touch **Back**. 

### Repeating play

There are two repeat play ranges for the CD playback: **Track** (track repeat) and **Disc** (disc repeat).

- **Touch Repeat on the function menu to select the repeat range.**

- **Disc** – Repeat the current disc
- **Track** – Repeat the current track
  - If you perform track search or fast forward/reverse, the repeat play range changes to **Disc**.
  - When playing discs with compressed audio and audio data (CD-DA), repeat play performs within the currently playing data type even if **Disc** is selected. 

### Playing tracks in random order

Random play lets you play back tracks on the CD in a random order.

- **Touch Random on the function menu to turn random play on.**

Tracks play in a random order.

- To turn random play off, touch **Random** again. 

### Scanning tracks of a CD

Scan play lets you hear the first 10 seconds of each track on the CD.

- 1 Touch Scan on the function menu to turn scan play on.**

The first 10 seconds of each track is played.

- 2 When you find the desired track touch Scan again.**

- After scanning of a CD is finished, normal playback of the tracks will begin again. 

## Listening to compressed audio

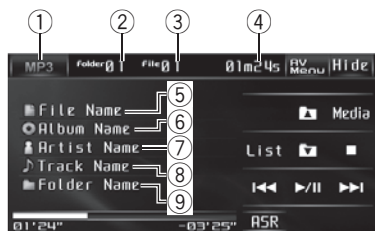

These are the basic steps necessary to play a compressed audio with your DVD player. More advanced compressed audio operation is explained starting in the following section. Refer to the next page.

- ① **Source icon**  
Shows the media type currently playing.
- ② **Folder number indicator**  
Shows the folder number currently playing.
- ③ **File number indicator**  
Shows the file number currently playing.
- ④ **Play time indicator**  
Shows the elapsed playing time of the current file.
- ⑤ **File name indicator**  
Shows the name of the currently playing file.
- ⑥ **Album title indicator**  
Shows the title of the currently playing album.
- ⑦ **Artist name indicator**  
Shows the artist name of the currently playing file.
- ⑧ **Track title indicator**  
Shows the name of the currently playing track.

- ⑨ **Folder name indicator**  
Shows the name of the currently playing folder.

### 1 Touch the source icon and then touch Disc to select the DVD player.

- Touch **Hide** to hide the touch panel keys.
- If no disc is loaded in the unit, you cannot select **Disc** (DVD player). Insert a disc in the unit. (Refer to page 17.)

### 2 Touch ▲ or ▼ to select a folder.

- You cannot select a folder that does not have a compressed audio file recorded in it.

### 3 To skip back or forward to another file, touch ◀◀ or ▶▶.

Touching ▶▶ skips to the start of the next file. Touching ◀◀ once skips to the start of the current file. Touching it again will skip to the previous file.

- You can also skip back or forward to another file by pressing ◀ or ▶ (TRK).

### 4 To perform fast forward or reverse, keep touching ◀◀ or ▶▶.

- You can also perform fast reverse/fast forward by pressing and holding ◀ or ▶ (TRK).



#### Notes

- This DVD player can play back a compressed audio recorded on CD-R/RW/ROM and DVD-R/RW/ROM. (Please see the following section for files that can be played back. Refer to page 96)
- Playback is carried out in order of file number. Folders are skipped if they contain no files. (If folder **01** (ROOT) contains no files, playback commences with folder **02**.)
- When playing back files recorded as VBR (variable bit rate) files, the play time will not be correctly displayed if fast forward or reverse operations are used.
- If specific information has not been recorded on a compressed audio disc, **No xxxx** will be displayed (e.g., **No Name**).

## Playing compressed audio

- If the characters recorded on the disc are not compatible with this unit, those characters will not be displayed.
- Text information may not be correctly displayed depending on the recorded environment. 

## Selecting files from the file name list

File name list lets you see the list of file names (or folder names) and select one of them to playback.

### 1 Touch List.

### 2 Touch your favorite file name (or folder name).

That selection will begin to play.

- You can start playback throughout the selected list by touching .
- When you have selected a folder, a list of the names of the files (or the folders) in it can be viewed. Repeat this operation to select the desired file name.
  - To return to the previous list (the folder one level higher), touch **Back**.
  - To return to folder **01** (ROOT), touch and hold **Back**. However, if folder **01** (ROOT) contains no files, playback commences with folder **02**.

### 3 Touch ESC to return to the ordinary display.

## Pausing playback

- Touch **▶/||** during playback.
  - To resume playback at the same point that you turned pause on, touch **▶/||** again. 

## Switching the media file type

If a disc contains a mixture of various media file types such as DivX and MP3, you can

switch between media file types to play. Refer to *Switching the media file type* on page 18.

- **Touch Media to switch between media file types.** 

## Using advanced sound retriever

Advanced sound retriever function automatically enhances compressed audio and restores rich sound.

- **Touch ASR repeatedly to select the desired setting.**

**Off** (off)—**ASR1**—**ASR2**

- **ASR2** is more effective than **ASR1**.



When you use this unit with a multi-channel processor (DEQ-P7650/DEQ-P6600) and switch the advanced sound retriever function to **ASR1** or **ASR2**, the volume will become slightly lower. The volume will become much lower for **ASR2** than it will for **ASR1**. Take care when you increase the volume for **ASR2** and then switch to **Off**, because the volume will suddenly seem much louder. 

## Introduction of advanced compressed audio operation

### 1 Touch AV Menu and then touch Function Menu to display the function names.

The function names are displayed and operable ones are highlighted.

### 2 Touch ESC to return to the playback display.

- To return to the previous display, touch **Back**. 

## Repeating play

For compressed audio playback, there are three repeat play ranges: **Folder** (folder repeat), **File** (one-track repeat) and **Disc** (repeat all tracks).

- **Touch Repeat on the function menu to select the repeat range.**

- **Disc** – Repeat all tracks
- **File** – Repeat the current track
- **Folder** – Repeat the current folder
  - If you select another folder during repeat play, the repeat play range changes to **Disc**.
  - If you perform track search or fast forward/reverse during **File**, the repeat play range changes to **Folder**.
  - When **Folder** is selected, it is not possible to play back a subfolder of that folder.
  - When playing discs with compressed audio and audio data (CD-DA), repeat play performs within the currently playing data type even if **Disc** is selected.

## Playing tracks in random order

Random play lets you play back tracks in a random order within the repeat range, **Folder** and **Disc**.

- **Touch Random on the function menu to turn random play on.**

Tracks will play in a random order within the previously selected repeat range.

- To turn random play off, touch **Random** again.

## Scanning folders and tracks

While you are using **Folder**, the beginning of each track in the selected folder plays for about 10 seconds. When you are using **Disc**, the beginning of the first track of each folder is played for about 10 seconds.

- 1 **Touch Scan on the function menu to turn scan play on.**

The first 10 seconds of each track of the current folder (or the first track of each folder) is played.

- 2 **When you find the desired track (or folder) touch Scan again.**

- After track or folder scanning is finished, normal playback of the tracks will begin again.

## Playing DivX/JPEG files

### Watching a DivX/JPEG

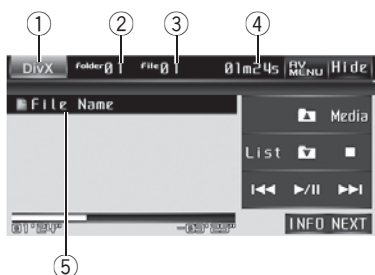

These are the basic steps necessary to play a DivX/JPEG with your DVD player. More advanced DivX/JPEG operation is explained starting in the following section. Refer to page 38.

#### ① Source icon

Shows which source has been selected.

#### ② Folder number indicator

Shows the folder number currently playing.

#### ③ File number indicator

Shows the file number currently playing.

#### ④ Play time indicator

Shows the elapsed playing time of the current file.

- When playing a JPEG disc, play time indicator does not appear.

#### ⑤ File name indicator

Shows the name of the currently playing file.

### 1 Touch the source icon and then touch Disc to select the DVD player.

- If no disc is loaded in the unit, you cannot select **Disc** (DVD player). Insert a disc in the unit. (Refer to page 17.)

### 2 Touch the screen to display the touch panel keys.

- Touch **Hide** to hide the touch panel keys.

### 3 Touch ▲ or ▼ to select a folder.

- You cannot select a folder that does not have a DivX/JPEG file recorded in it.

### 4 To skip back or forward to another file, touch ◀◀ or ▶▶.

Touching ▶▶ skips to the start of the next file. Touching ◀◀ once skips to the start of the current file. Touching it again will skip to the previous file.

- You can also skip back or forward to another file by pressing ◀ or ▶ (TRK).

### 5 To perform fast forward or reverse, keep touching ◀◀ or ▶▶.

When DivX disc is playing, if you keep touching ◀◀ or ▶▶ for five seconds, the icon ◀◀ or ▶▶ is highlighted. When this happens, fast reverse/fast forward continues even if you release ◀◀ or ▶▶. To resume playback at a desired point, touch ▶/||.

- This is fast forward and reverse operation only for the file being played. This operation is canceled when the previous or next file is reached.
- You can also perform fast reverse/fast forward by pressing and holding ◀ or ▶ (TRK).
- When playing JPEG file, performing this operation enables you to search every 10 files.







#### Notes

- This DVD player can play back a DivX file recorded on CD-R/RW/ROM and DVD-R/RW/ROM. (Please see the following section for files that can be played back. Refer to page 98.)
- This unit can play back a JPEG file recorded on CD-R/RW/ROM or USB storage device. (Please see the following section for files that can be played back. Refer to page 98.)
- Playback is carried out in order of file number. Folders are skipped if they contain no files. (If folder **01** (ROOT) contains no files, playback commences with folder **02**.)

## Viewing a JPEG slideshow

When loading a CD/CD-R/RW containing JPEG picture files, this unit automatically starts a slideshow from the first folder/picture on the disc. The player displays the pictures in each folder in alphabetical order.

The table below shows the controls for viewing a slideshow.

Key	What it does
	Starts the slideshow, pauses the slideshow or restarts a paused disc.
	Displays the previous picture.
	Displays the next picture.
	Rotates the displayed picture 90° clockwise.



## Playing DivX® VOD content

Some DivX VOD (video on demand) content may only be playable a fixed number of times. When you load a disc containing this type of DivX VOD content, the remaining number of plays is shown on-screen and you then have the option of playing the disc (thereby using up one of the remaining plays), or stopping. If you load a disc that contains expired DivX VOD content (for example, content that has zero remaining plays), **Rental Expired.** is displayed.

- If your DivX VOD content allows an unlimited number of plays, then you may load the disc into your player and play the content as often as you like, and no message will be displayed.
- Playable number of times is displayed with **Remaining Views.**

### Important

- In order to play DivX VOD content on this unit, you first need to register the unit with your DivX VOD content provider. About your regis-

tration code, refer to *Displaying your DivX® VOD registration code* on page 52.

- DivX VOD content is protected by a DRM (Digital Rights Management) system. This restricts playback of content to specific, registered devices.

### ● If the message is displayed after loading a disc containing DivX VOD content, touch **Play.**

Playback of the DivX VOD content will start.

- To skip to the next file, touch **Next Play.**
- If you do not want to play the DivX VOD content, touch **Stop.** 

## Selecting files from the file name list

File name list lets you see the list of file names (or folder names) and select one of them to playback.

### 1 Touch List.

### 2 Touch your favorite file name (or folder name).

That selection will begin to play.

- When you have selected a folder, a list of the names of the files (or the folders) in it can be viewed. Repeat this operation to select the desired file name.
- You can start playback throughout the selected list by touching .
- To return to the previous list (the folder one level higher), touch **Back.**
- To return to folder **01** (ROOT), touch and hold **Back.** However, if folder **01** (ROOT) contains no files, playback commences with folder **02.**

### 3 Touch **ESC** to return to the ordinary display.

## Playing DivX/JPEG files

### Displaying text information on DivX/JPEG disc

Text information recorded on a DivX/JPEG disc can be displayed.

#### ● Touch INFO.

Touch **INFO** repeatedly to switch between the following settings:

**Folder Name** (folder name)—**File Name** (file name)

- If the characters recorded on the disc are not compatible with this unit, those characters will not be displayed.

### Pausing playback

#### ● Touch ►/II during playback.

- To resume playback at the same point that you turned pause on, touch ►/II again.

### Switching the media file type

If a disc contains a mixture of various media file types such as DivX and MP3, you can switch between media file types to play. Refer to *Switching the media file type* on page 18.

#### ● Touch Media to switch between media file types.

### Searching for the part you want to play

You can use the time search function to specify the time on a disc at which play starts.

- This function is available for DivX disc.
- This function is not possible when disc playback has been stopped.

#### 1 Touch Search.

#### 2 Touch 0 to 9 to input the desired number.

- To cancel the inputted numbers, touch **C**.

- To select 1 hour 11 minutes, convert the time into 071 minutes 00 seconds and touch **0, 7, 1, 0** and **0** in that order.

#### 3 Touch ◀.

This starts playback from the selected part.

### Changing audio language during playback (Multi-audio)

You can switch audio language during playback when playing a file recorded with dialog in two or more languages.

- This function is available for DivX disc.

#### ● Touch Audio during playback.

Each time you touch **Audio** it switches between audio systems.

- Touching **Audio** during fast forward/fast reverse, pause or slow motion playback returns you to normal playback.

### Changing the subtitle language during playback (Multi-subtitle)

You can switch subtitle language during playback when playing file recorded with subtitles in one or more languages.

- This function is available for DivX disc.

#### ● Touch Subtitle during playback.

Each time you touch **Subtitle** it switches between subtitle languages.

- Touching **Subtitle** during fast forward/fast reverse, pause or slow motion playback returns you to normal playback.

### Capture an image in JPEG files

Image data can be captured in order to use it for wallpaper. Images can be stored in this unit, and recall easily.

- This function is available for JPEG disc.

## Playing DivX/JPEG files

- This unit can store only one image data. Old image is overwritten with new one.

**1 Touch ►/II to pause the slideshow when the desired image is displayed.**

**2 Touch Capture.**  
**Captureing the image** is displayed.

**3 When Do you save this image? is displayed, touch Yes.**

While storing the image to this unit, **Saving the image Don't switch off the battery.** is displayed. After stored completely, **Image saved** is displayed.

- To cancel the storage process, touch **No.**

## Introduction of advanced DivX/JPEG operation

**1 Touch AV Menu and then touch Function Menu to display the function names.**

The function names are displayed and operable ones are highlighted.

**2 Touch ESC to return to the playback display.**

- To return to the previous display, touch **Back.**

## Repeating play

For DivX video file playback, there are three repeat play ranges: **Folder** (folder repeat), **File** (file repeat) and **Disc** (repeat all files).

For JPEG picture file playback, there are two repeat play ranges: **Folder** (folder repeat) and **Disc** (repeat all files).

● **Touch Repeat on the function menu to select the repeat range.**

- **Disc** – Repeat all files
- **Folder** – Repeat the current folder
- **File** – Repeat just the current file

- If you select another folder during repeat play, the repeat play range changes to **Disc**.
- If you perform track search or fast forward/reverse during **File**, the repeat play range changes to **Folder**.
- When **Folder** is selected, it is not possible to play back a subfolder of that folder.

## Playing tracks in random order

When playing a JPEG disc, random play lets you play back files in a random order within the repeat range, **Folder** and **Disc**.

- This function is available for JPEG disc.

● **Touch Random on the function menu to turn random play on.**

Files will play in a random order within the previously selected **Folder** or **Disc** ranges.

- To turn random play off, touch **Random** again.

## Playing songs in a USB storage device

### Basic Operations

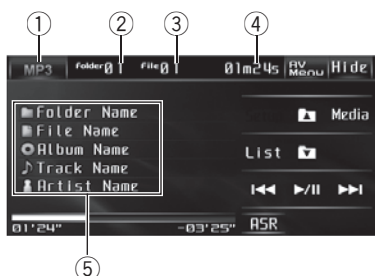

For details about the supported device, refer to *Portable audio player compatibility* on page 8. Operation of JPEG in a USB storage device is the same as JPEG on a disc.

#### ① Source icon

Shows the media type currently playing.

#### ② Folder number indicator

Shows the folder number currently playing.

#### ③ File number indicator

Shows the file number currently playing.

- Last four-digit can be displayed as the file number.

#### ④ Play time indicator

Shows the elapsed playing time of the current file.

#### ⑤ Song information

Shows detailed information of currently playing song.

### 1 Touch the source icon and then touch USB to select the USB.

- When the source icon is not displayed, you can display it by touching the screen.
- Touch **Hide** to hide the touch panel keys.

### 2 Touch ▲ or ▼ to select a folder.

- You cannot select a folder that does not have a compressed audio file recorded in it.

### 3 To skip back or forward to another file, touch ◀◀ or ▶▶.

Touching ▶▶ skips to the start of the next file. Touching ◀◀ once skips to the start of the

current file. Touching it again will skip to the previous file.

- You can also skip back or forward to another file by pressing ◀ or ▶ (**TRK**).

### 4 To perform fast forward or reverse, keep touching ◀◀◀ or ▶▶▶.

- You can also perform fast reverse/fast forward by pressing and holding ◀ or ▶ (**TRK**).



#### Notes

- Optimum performance of this unit may not be obtained depending on the connected USB portable audio player/USB memory.
- If folder 01 (ROOT) contains no files, playback commences with folder 02.
- If an error message or icon is displayed, refer to *Error messages* on page 90.
- When the USB portable audio player having battery charging function is connected to this unit and the ignition switch is set to ACC or ON, the battery is charged.
- You can disconnect the USB portable audio player/USB memory anytime you want to finish listening to it.
- If USB portable audio player/USB memory is connected to this unit, the source is changed to USB automatically. If you do not use an USB device, disconnect it from this unit. Depending on the connected USB device, turning on the ignition switch while USB device is connected to this unit may change the source automatically.
- If the characters recorded on the audio file are not compatible with this unit, those characters will not be displayed.
- Text information may not be correctly displayed depending on the recorded environment. □

## Selecting files from the file name list

The operation is the same as that of the built-in DVD player.

Refer to *Selecting files from the file name list* on page 33. □

## Pausing compressed audio playback

- **Touch ►/|| during playback.**
  - To resume playback at the same point that you turned pause on, touch ►/|| again. 

## Switching the media file type

The operation is the same as that of the built-in DVD player.  
If a USB portable audio player/USB memory contains compressed audio files and JPEG file, you can switch between media file types to play. Refer to *Switching the media file type* on page 18. 

## Using advanced sound retriever

Advanced sound retriever function automatically enhances compressed audio and restores rich sound.

- **Touch ASR repeatedly to select the desired setting.**

**Off** (off)—**ASR1**—**ASR2**

- **ASR2** is more effective than **ASR1**.

### Note

When you use this unit with a multi-channel processor (DEQ-P7650/DEQ-P6600) and switch the advanced sound retriever function to **ASR1** or **ASR2**, the volume will become slightly lower. The volume will become much lower for **ASR2** than it will for **ASR1**. Take care when you increase the volume for **ASR2** and then switch to **Off**, because the volume will suddenly seem much louder. 

## Introduction to advanced operations

- 1 **Touch AV Menu and then touch Function Menu to display the function names.**

The function names are displayed and operable ones are highlighted.

- 2 **Touch ESC to return to the playback display.**

- To return to the previous display, touch **Back**.

## Function and operation

**Repeat**, **Random** and **Scan** operations are basically the same as that of the built-in DVD player.

Function name	Operation
<b>Repeat</b>	Refer to <i>Repeating play</i> on page 34. However, the repeat play ranges you can select are different from that of the built-in DVD player. The repeat play ranges of the USB portable audio player/USB memory are: <ul style="list-style-type: none"> <li>• <b>File</b> – Repeat just the current file</li> <li>• <b>Folder</b> – Repeat the current folder</li> <li>• <b>All</b> – Repeat all files</li> </ul>
<b>Random</b>	Refer to <i>Playing tracks in random order</i> on page 34.
<b>Scan</b>	Refer to <i>Scanning folders and tracks</i> on page 34.

### Notes

- If you select another folder during repeat play, the repeat play range changes to **All**.
- If you perform track search or fast forward/reverse during **File**, the repeat play range changes to **Folder**.
- When **Folder** is selected, it is not possible to play back a subfolder of that folder.
- After file or folder scanning is finished, normal playback of the files begins again. 

## Using iPod

### Basic Operations

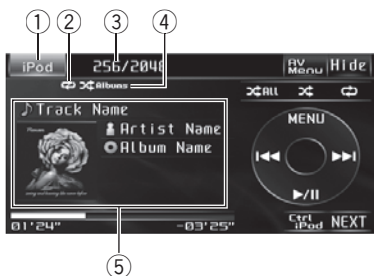

- You can use this unit to control an iPod by using a cable (e.g., CD-IU50), which is sold separately.
- If an iPod with video capabilities is connected to this unit via interface cable (e.g. CD-IU50V), which is sold separately, you can enjoy the video contents of the iPod as the **iPod** source. In this case, set the **AUX1** to **iPod**. Refer to *Switching the auxiliary setting on page 53*.

#### ① Source icon

Shows which source has been selected.

#### ② Repeat indicator

Shows when repeat range is set to or .

#### ③ Song number indicator

Up to 65 535 can be displayed as the song number.

#### ④ Shuffle indicator

Shows when random play is set to **Songs** or **Albums**.

#### ⑤ Song information

Shows detailed information of currently playing song.

### 1 Touch the source icon and then touch iPod to select the iPod.

While connected to this unit, **PIONEER, Accessory Attached** or ✓ (check mark) is displayed on the iPod.

- When the source icon is not displayed, you can display it by touching the screen.

- Touch **Hide** to hide the touch panel keys.
- Before connecting the dock connector of this unit to the iPod, disconnect the headphones from the iPod.
- Depending on the model of iPod or the data size in the iPod, there may be a delay to start playing after connection.
- After the iPod has been connected to this unit, use touch panel keys to select the iPod.
- When removing the iPod from this unit, this unit is turned off.

### 2 To skip back or forward to another song/video, touch ◀◀ or ▶▶.

- You can also skip back or forward to another song/video by pressing ◀ or ▶ (**TRK**).

### 3 To perform fast forward or reverse, keep touching ◀◀ or ▶▶.

When video is playing, if you keep touching ◀◀ or ▶▶ for five seconds, the icon ◀◀ or ▶▶ is highlighted. When this happens, fast reverse/fast forward continues even if you release ◀◀ or ▶▶. To resume playback at a desired point, touch ▶/||.

- You can also perform fast reverse/fast forward by pressing and holding ◀ or ▶ (**TRK**).

### 4 When playing a file with chapter, touch ◀◀ or ▶▶ to select a chapter.



#### Notes

- Read the precautions for iPod in the following section. Refer to page 98.
- If an error message or icon is displayed, refer to *Error messages* on page 90.
- Connect directly the dock connector cable to the iPod so that this unit works properly.
- When the ignition switch is set to ACC or ON, the iPod's battery is charged while the iPod is connected to this unit.
- While the iPod is connected to this unit, the iPod cannot be turned on or off.
- The iPod is turned off about two minutes after the ignition switch is set to OFF.
- If specific information is not recorded on the iPod, **No xxxx** will be displayed (e.g., **No Name**).

- If the characters recorded on the iPod are not compatible with this unit, those characters are not displayed.
- This unit can display the album art. While loading the album art information from iPod, functions may not work properly.
  - List operation may not function promptly.
  - Time display and actual time may not match.

If many songs and album art have been stored in iPod, loading may take long time. 

## Playing video

This unit can play video if an iPod with video capabilities is connected.

- To pause video playback, touch **MENU**.
- This unit can play back "Movies", "Music videos", "Video Podcast" and "TV show" which are downloaded from iTunes store.
- Change the video setting on the iPod so that the iPod can output the video to an external device, before you display the video screen.
- iPod video image is not displayed on the PAL rear monitor.
  - When the control mode is set to iPod, it is possible to change the signal between PAL and NTSC from iPod.
  - When the control mode is set to this unit, it is not possible to display the video on the PAL monitor.
  - For about control mode, see the following section. Refer to *Operating this unit's iPod function from your iPod* on page 44.
- For details, refer to the iPod's manuals.

### 1 Touch MENU to display iPod menus.

### 2 Touch Video.

- To return to the music operation screen, touch **Music**.

### 3 Play video on the iPod.

## Browsing for a song/video

Operations to control an iPod with this unit is designed to be as close to the iPod as possible to make operation and song/video search easy.

- If the characters recorded on the iPod are not compatible with this unit, those characters are not displayed.

## Searching songs/videos by category

### 1 Touch MENU to display iPod menus.

### 2 Touch one of the categories in which you want to search for a song/video.

#### When browsing for a song

- **Playlists** (playlists)
- **Artists** (artists)
- **Albums** (albums)
- **Songs** (songs)
- **Podcasts** (podcasts)
- **Genres** (genres)
- **Composers** (composers)
- **Audiobooks** (audiobooks)

#### When browsing for a video

- **Video Playlists** (video playlists)
- **Movies** (movies)
- **Music Videos** (music videos)
- **Video Podcasts** (video podcasts)
- **TV Shows** (TV shows)

### 3 Touch a list title that you want to play.

Repeat this operation until you find the desired song/video.

- You can start playback throughout the selected list by touching .
- To return to the previous menu, touch **Back**.

### 4 Touch ESC to return to the ordinary display.

## Using iPod

### Searching by alphabet in the list

- 1 **Select a category.** (Refer to *Searching songs/videos by category* on the previous page.)
- 2 **When a list for the selected category is displayed, touch ABC to switch to alphabet search mode.**  
Alphabet search mode is displayed.
- 3 **Touch ◀ or ▶ to select the first letter you are looking for.**



#### 4 **Touch ↵ to show entries starting with the letter you chose.**

While searching, **Searching** flashes. In this condition, touch panel key operation is not available.

- To refine the search with a different letter, touch **Cancel**.

#### 5 **Touch a list title that you want to play.**

Repeat this operation until you find the desired song/video.

- You can start playback throughout the selected list by touching .
- To return to the previous menu, touch **Back**. 

## Displaying text information on iPod Video

### ● **Touch INFO.**

**Song Title** (song title)—**Artist Name** (artist name)—**Album Title** (album title)

- If specific information is not recorded on the iPod, **No xxxx** will be displayed (e.g., **No Name**).
- If the characters recorded on the iPod are not compatible with this unit, those characters are not displayed. 

## Pausing playback

- **Touch ▶/|| during playback.**
  - To resume playback at the same point that you turned pause on, touch ▶/|| again. 

## Using advanced sound retriever

Advanced sound retriever function automatically enhances compressed audio and restores rich sound.

### ● **Touch ASR repeatedly to select the desired setting.**

**Off** (off)—**ASR1**—**ASR2**



- **ASR2** is more effective than **ASR1**.







### Note

When you use this unit with a multi-channel processor (DEQ-P7650/DEQ-P6600) and switch the advanced sound retriever function to **ASR1** or **ASR2**, the volume will become slightly lower. The volume will become much lower for **ASR2** than it will for **ASR1**. Take care when you increase the volume for **ASR2** and then switch to **Off**, because the volume will suddenly seem much louder. 



## Repeating play

For playback of the songs/videos on the iPod, there are two repeat play ranges:  (repeat one song/video) and  (repeat all songs/videos in the list).

- While repeat play range is set to , you cannot select the other songs/videos. However, you can select other songs/videos while browsing.
- **Touch  to select the repeat range.**
  -  – Repeat just the current song/video
  -  – Repeat all songs/videos in the selected list 

## Playing songs/videos in a random order (shuffle)

For playback of songs/videos on the iPod, there are two random play methods: **Songs** (play back songs/videos in a random order) and **Albums** (play back albums in a random order).

- **Touch  to select the random play method.**
  - **Songs** – Play back songs/videos in the selected list in random order.
  - **Albums** – Play back songs/videos from a randomly selected album in order.
    - To cancel the random play, touch  repeatedly until the shuffle icon is turned off. 

## Playing all songs in a random order (shuffle all)

This method plays all songs on the iPod randomly.

- **Touch  to turn shuffle all on.**  
All songs on the iPod play randomly. 

## Operating this unit's iPod function from your iPod

This unit's iPod function can be operated from your iPod. Sound can be heard from the car's speakers, and operation can be conducted from your iPod.

- While this function is in use, even if the ignition key is turned off, the iPod will not be turned off. To turn off power, operate the iPod.

### 1 Touch to switch the control mode to iPod.

- Touching  switches the control mode to this unit.
- Even if this function is performed, track up/down, chapter up/down, fast forward/reverse and

play/pause can be operated from this unit. Also, it is possible to display the text information while playing back video.

### 2 Operate the connected iPod to select a song/video and play.

## Selecting songs from lists related to the currently playing song

Lists related to the currently playing song are displayed. You can select songs from the following lists.

- Album list of currently playing artist
- Song list of currently playing album
- Album list of currently playing genre
- Depending on the number of files in the iPod, there may be a delay when displaying a list.

### 1 Touch Link Play.

Link play selection screen is displayed.

### 2 Touch a desired mode.

- **Artists** – Plays songs related to the currently playing artist.
- **Albums** – Plays songs related to the currently playing album.
- **Genres** – Plays songs related to the currently playing genre.

While searching the song, **Link Play..** flashes. In this condition, touch panel key operation is not available.

- If the related albums/songs are not found, **Not Found** is displayed.

### 3 Display returns to the ordinary display and playback begin.

## Changing audiobook speed

While listening to an audiobook on iPod, playback speed can be changed.

## Using iPod

- **Touch AudioBooks to select your favorite setting.**

- **Faster** – Playback faster than normal speed
- **Normal** – Playback in normal speed
- **Slower** – Playback slower than normal speed

## Changing the screen mode

While video is playing, you can select the display mode between widescreen (16:9) and standard (4:3) screen.

- **Touch Wide Screen.**

- To switch to standard (4:3) screen, touch **Wide Screen** again.

## Introduction of audio adjustments

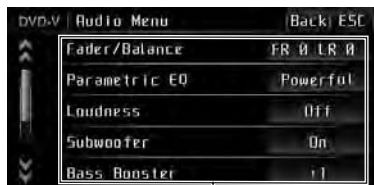

### ① Audio display

Shows the audio adjustment status.

### 📌 Important

If the multi-channel processor (DEQ-P7650/DEQ-P6600) is connected to this unit, the audio function will be changed to the multi-channel processor's audio menu. For details, refer to *Introduction of DSP adjustments* on page 77.

### 1 Touch AV Menu and then touch Audio Menu to display the audio function names.

The audio function names are displayed and operable ones are highlighted.

- When selecting FM as the source, you cannot switch to **Source Level Adjuster**.
- When selecting Bluetooth telephone as the source, you can only switch to **Fader/Balance**.

### 2 Touch ESC to return to the ordinary display.

- To return to the previous display, touch **Back**.

## Using balance adjustment

You can change the fader/balance setting so that it can provide the ideal listening environment in all occupied seats.

### 1 Touch Fader/Balance on the audio function menu.

### 2 Touch ▲ or ▼ to adjust front/rear speaker balance.

**Front:15 to Rear:15** is displayed as the front/rear speaker balance moves from front to rear.

- **FR: 0/LR: 0** is the proper setting when only two speakers are used.
- When the rear output setting is **Subwoofer**, you cannot adjust front/rear speaker balance. Refer to *Setting the rear output and subwoofer controller* on page 54.

### 3 Touch ◀ or ▶ to adjust left/right speaker balance.

**Left:15 to Right:15** is displayed as the left/right speaker balance moves from left to right.

## Using the equalizer

The equalizer lets you adjust the equalization to match the car's interior acoustic characteristics as desired.

You can adjust the center frequency and the Q factor (curve characteristics) of each currently selected curve band (**Low/Mid/High**).

- The actual range of the adjustments are different depending on which equalizer curve is selected.

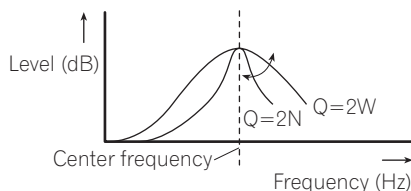

### 1 Touch Parametric EQ on the audio function menu.

### 2 Touch ◀ or ▶ on EQ Select to select the equalizer.

Display	Equalizer curve
Powerful	Powerful
Natural	Natural
Vocal	Vocal

## Audio Adjustments

Custom	Custom
Flat	Flat
Super Bass	Super bass

▪ **Custom** is an adjusted equalizer curve that you create. If you make adjustments to an equalizer curve, the equalizer curve setting is memorized in **Custom**.

▪ When **Flat** is selected, no supplement or correction is made to the sound. This is useful to check the effect of the equalizer curves by switching alternatively between **Flat** and a set equalizer curve.

**3 Touch ◀ or ▶ on Band to select the equalizer band to adjust.**

**Low (low)—Mid (mid)—High (high)**

**4 Touch ◀ or ▶ on Frequency to select the frequency to adjust.**

Low: **40Hz—80Hz—100Hz—160Hz**

Mid: **200Hz—500Hz—1kHz—2kHz**

High: **3.15kHz—8kHz—10kHz—12.5kHz**

**5 Touch ◀ or ▶ on Q.Factor to select the Q factor.**

**2Wide—1Wide—1Narrow—2Narrow**

**6 Touch ▲ or ▼ to adjust the level of the equalizer band.**

**+12dB to -12dB** is displayed as the level is increased or decreased.

▪ You can then select another band and adjust the level.

## Adjusting loudness

Loudness compensates for deficiencies in the low- and high-sound ranges at low volume.

**1 Touch Loudness on the audio function menu.**

**2 Touch ▶ to turn loudness on.**

▪ To turn loudness off, touch ◀.

**3 Touch ◀ or ▶ to select a desired level.**

**Low (low)—Mid (mid)—High (high)**

## Using subwoofer output

This unit is equipped with a subwoofer output which can be turned on or off.

- When the subwoofer output is on, you can adjust the cut-off frequency and the output level of the subwoofer.

**1 Touch Subwoofer on the audio function menu.**

**2 Touch ▶ next to Subwoofer to turn subwoofer output on.**

▪ To turn subwoofer output off, touch ◀.

**3 Touch ◀ or ▶ next to Phase to select the phase of subwoofer output.**

Touch ▶ to select normal phase and **Normal** appears in the display. Touch ◀ to select reverse phase and **Reverse** appears in the display.

**4 Touch ◀ or ▶ next to Level to adjust the output level of the subwoofer.**

**+6 to -24** is displayed as the level is increased or decreased.

**5 Touch ◀ or ▶ next to Frequency to select cut-off frequency.**

Each time you touch ◀ or ▶ selects cut-off frequencies in the following order:

**50Hz—63Hz—80Hz—100Hz—125Hz**

Only frequencies lower than those in the selected range are outputted from the subwoofer.

## Boosting the bass

Bass boost function boosts the bass level of sound.

**1 Touch Bass Booster on the audio function menu.**

**2 Touch ◀ or ▶ to select a desired level.**

**0 to +6** is displayed as the level is increased or decreased.

## Using the high pass filter

When you do not want low sounds from the subwoofer output frequency range to play from the front or rear speakers, turn on the HPF (high pass filter). Only frequencies higher than those in the selected range are output from the front or rear speakers.

### 1 Touch High Pass Filter on the audio function menu.

### 2 Touch ► next to High Pass Filter to turn high pass filter on.

- To turn high pass filter off, touch ◀.

### 3 Touch ◀ or ► next to Frequency to select cut-off frequency.

Each time you touch ◀ or ► selects cut-off frequencies in the following order:

**50Hz—63Hz—80Hz—100Hz—125Hz**

Only frequencies higher than those in the selected range are output from the front or rear speakers. ◻



### Notes

- The AM volume level can also be adjusted with source level adjustments.
- Video CD, CD, compressed audio and DivX are set to the same source level adjustment volume automatically.
- iPod and USB storage device are set to the same source level adjustment volume automatically.
- External unit 1 and external unit 2 are set to the same source level adjustment volume automatically. ◻

## Adjusting source levels

SLA (source level adjustment) lets you adjust the volume level of each source to prevent radical changes in volume when switching between sources.

- Settings are based on the FM volume level, which remains unchanged.

### 1 Compare the FM volume level with the level of the source you wish to adjust.

### 2 Touch Source Level Adjuster on the audio function menu.

### 3 Touch ◀ or ► to adjust the source volume.

Each time you touch ◀ or ► it increases or decreases the source volume.

**+4 to -4** is displayed as the source volume is increased or decreased.

## Setting up the DVD player

### Introduction of DVD setup adjustments



#### ① DVD setup menu display

Shows the DVD setup menu names.

You can use this menu to change audio, subtitle, parental lock and other DVD settings.

#### 1 Touch .

**Setup** will be displayed instead of **Menu**.

#### 2 Touch **Setup**.

The DVD setup function names are displayed.

#### 3 Touch **ESC** to return to the playback display.

- To return to the previous display, touch

**Back**. .

### Setting the subtitle language

You can set a desired subtitle language. If the selected subtitle language is recorded on the DVD, subtitles are displayed in that language.

#### 1 Touch **Subtitle Language** on the DVD setup menu.

A subtitle language menu is displayed.

#### 2 Touch the desired language.

A subtitle language is set.

- If you have selected **Others**, refer to *When you select Others* on this page.



#### Notes

- If the selected language is not recorded on the disc, the language specified on the disc is displayed.
- You can also switch the subtitle language by touching **Subtitle** during playback. (Refer to *Changing the subtitle language during playback (Multi-subtitle)* on page 25.)
- Even if you use **Subtitle** during playback to switch the subtitle language, this does not affect the settings here.

### When you select Others

When you select **Others**, a language code input display is shown. Please see the following section to input the four-digit code of the desired language. Refer to *Language code chart for DVD* on page 101.

#### 1 Touch 0 to 9 to input the language code.

- To cancel the inputted numbers, touch **C**.

#### 2 Touch .

### Setting the audio language

You can set the preferred audio language.

#### 1 Touch **Audio Language** on the DVD setup menu.

An audio language menu is displayed.

#### 2 Touch the desired language.

The audio language is set.

- If you have selected **Others**, refer to *When you select Others* on this page.



#### Notes

- If the selected language is not recorded on the disc, the language specified on the disc is outputted.

## Setting up the DVD player

- You can also switch the audio language by touching **Audio** during playback. (Refer to *Changing audio language during playback (Multi-audio)* on page 24.)
- Even if you use **Audio** during playback to switch the audio language, this does not affect the settings here. 

### Setting the menu language

You can set the preferred language for displays of menus recorded on a disc.

#### 1 Touch Menu Language on the DVD setup menu.

A menu language menu is displayed.

#### 2 Touch the desired language.

The menu language is set.

- If you have selected **Others**, refer to *When you select Others* on the previous page.



#### Note

If the selected language is not recorded on the disc, the language specified on the disc is displayed. 

### Setting the angle icon display

You can set it up so that the angle icon appears on scenes where the angle can be switched.

- Initially, this function is set to on.
- **Touch Multi Angle on the DVD setup menu to turn angle icon display on.**
  - To turn the angle icon display off, touch **Multi Angle** again. 

### Setting the aspect ratio

There are two kinds of display. A wide screen display has a width-to-height ratio (TV aspect) of 16:9, while a regular display has a TV aspect

of 4:3. Be sure to select the correct TV aspect for the display connected to **V OUT**.

- When using a regular display, select either **Letter Box** or **Pan Scan**. Selecting **16:9** may result in an unnatural picture.
- If you select the TV aspect, the unit's display changes to the same setting.

#### ● Touch TV Aspect on the DVD setup menu to select the TV aspect.

Touch **TV Aspect** repeatedly until the desired TV aspect appears in the display.

- **16:9** – Wide screen picture (16:9) is displayed as it is (initial setting)
- **Letter Box** – The picture is the shape of a letterbox with black bands at the top and bottom of the screen
- **Pan Scan** – The picture is cut short at the right and left of the screen



#### Notes

- When playing discs that do not specify **Pan Scan**, playback is with **Letter Box** even if you select **Pan Scan** setting. Confirm whether the disc package bears the **16:9 LB** mark.
- Some discs do not enable changing of the TV aspect. For details, refer to the disc's instructions. 

### Setting the slide show interval

Slide show is possible when JPEG files are playing with this unit. In this setting, interval of slide show can be set.

#### ● Touch Slide Show on the DVD setup menu to select the slide show interval.

Touch **Slide Show** repeatedly until the desired setting appears in the display.

- **10sec** – JPEG images switch at intervals of 10 seconds
- **20sec** – JPEG images switch at intervals of 20 seconds
- **30sec** – JPEG images switch at intervals of 30 seconds

## Setting up the DVD player

- **Manual** – JPEG images can be switched manually 

### Setting the parental lock

Some DVD video discs let you use parental lock to restrict children from viewing violent and adult-oriented scenes. You can set the parental lock to your desired level.

- When you set a parental lock level and then play a disc featuring parental lock, code number input indications may be displayed. In this case, playback will begin when the correct code number is input.

### Setting the code number and level

You need to have registered a code number for playing back discs with parental lock.

#### 1 Touch Parental on the DVD setup menu.

#### 2 Touch 0 to 9 to input a four digit code number.

- To cancel the inputted numbers, touch **C**.

#### 3 Touch .

The code number is set, and you can now set the level.

#### 4 Touch any of 1 to 8 to select the desired level.

The parental lock level is set.

- **8** – Playback of the entire disc is possible (initial setting)
- **7 to 2** – Playback of discs for children and non-adult-oriented discs is possible
- **1** – Playback of discs for children only is possible

#### Notes

- We recommend to keep a record of your code number in case you forget it.
- The parental lock level is recorded on the disc. Look for the level indication written at the disc package, included literature or on the disc itself. Parental lock of this unit is not possible if

a parental lock level is not recorded in the disc.

- With some discs, the parental lock may be active only on the scenes with certain levels. The playback of those scenes will be skipped. For details, refer to the instruction manual that came with the discs.

### Changing the level

You can change the set parental lock level.

#### 1 Touch Parental on the DVD setup menu.

#### 2 Touch 0 to 9 to input the registered code number.

#### 3 Touch .

This enters the code number, and you can now change the level.

- If you input an incorrect code number, the icon  is displayed. Touch **C** and input the correct code number.
- If you forget your code number, refer to *If you forget your code number* on this page.

#### 4 Touch any of 1 to 8 to select the desired level.

The new parental lock level is set.

### If you forget your code number

Please see the following section, and touch **C** 10 times. Refer to *Changing the level* on this page. The registered code number is canceled, letting you register a new one. 

### Setting the DivX subtitle file

You can select whether to display DivX external subtitles or not.

- The DivX subtitles will be displayed even when **Custom** is selected if no DivX external subtitle files exist.
- **Touch DivX Subtitle on the DVD setup menu to select the desired subtitle setting.**
  - **Original** – Display the DivX subtitles

## Setting up the DVD player

- **Custom** – Display the DivX external subtitles



### Notes

- Up to 42 characters can be displayed on one line. If more than 42 characters are set, the line breaks and the characters are displayed on the next line.
- Up to 126 characters can be displayed on one screen. If more than 126 characters are set, the excess characters will not be displayed.

- **Touch Digital Output on the DVD setup menu to select the desired digital output setting.**

- **Stream** – The Dolby Digital/DTS signal is output as it is (initial setting)
- **Linear PCM** – The Dolby Digital/DTS signal is converted to and output as a linear PCM signal.

## Displaying your DivX® VOD registration code

In order to play DivX VOD (video on demand) content on this unit, you first need to register the unit with your DivX VOD content provider. You do this by generating a DivX VOD registration code, which you submit to your provider.

- **Touch DivX VOD on the DVD setup menu.**

Your 8-digit registration code is displayed.

- Make a note of the code as you will need it when you register with a DivX VOD provider.

## Setting for digital output

Audio which is outputted from digital output of this unit can be selected. Normally, set to **Stream**. If this unit's digital output is not used, there is no need to change settings.

- Selecting **Linear PCM** enables you to switch the output channel if playing the following type of discs. (Refer to *Selecting audio output* on page 26.)
  - Dual mono mode DVD video discs
  - Bilingual DVD-VR discs

## Initial Settings

### Adjusting initial settings



#### ① Function display

Shows the function names.

Using the initial settings, you can customize various system settings to achieve optimal performance from this unit.

**1 Touch the source icon and then touch Off to turn this unit off.**

**2 Touch the screen to display the touch panel keys.**

**3 Touch AV Menu and then touch Initial Menu to display the function names.**

The function names are displayed and operable ones are highlighted.

**4 Touch ESC to return to the ordinary display.**

- To return to the previous display, touch **Back**.

### Switching the auxiliary setting

Auxiliary devices connected to this unit can be activated individually. Set each AUX source to ON when using. For more information about connecting or using auxiliary devices, refer to *Using the AUX source* on page 63.

### Switching the auxiliary 1 setting

● **Touch AUX1 on the initial menu to select desired setting.**

- **Video** – auxiliary video device connected with 4-pole mini plug cable (e.g., CD-V150M)
- **Audio** – auxiliary device connected with stereo mini plug cable
- **iPod** – an iPod with video capabilities connected with CD-IU50V
- **Off** – No auxiliary device is connected

### Switching the auxiliary 2 setting

● **Touch AUX2 on the initial menu to turn auxiliary 2 setting on.**

- To turn auxiliary 2 setting off, touch **AUX2** again.

### Setting the FM tuning step

The FM tuning step employed by seek tuning can be switched between 100 kHz, the preset step, and 50 kHz.

● **Touch FM Step on the initial menu to select the FM tuning step.**

Touching **FM Step** will switch the FM tuning step between 50 kHz and 100 kHz. The selected FM tuning step will appear in the display.

- If seek tuning is performed in 50 kHz steps, stations may be tuned in imprecisely. Tune in the stations with manual tuning or use seek tuning again.

### Setting the AM tuning step

The AM tuning step can be switched between 9 kHz, the preset step, and 10 kHz. When using the tuner in North, Central or South America, reset the tuning step from 9 kHz (531 kHz to 1 602 kHz allowable) to 10 kHz (530 kHz to 1 640 kHz allowable).

- **Touch AM Step on the initial menu to select the AM tuning step.**

Touching **AM Step** will switch the AM tuning step between 9 kHz and 10 kHz. The selected AM tuning step will appear in the display. 

## Setting the rear output and subwoofer controller

This unit's rear output (rear speaker leads output and RCA rear output) can be used for full-range speaker (**Full**) or subwoofer (**Subwoofer**) connection. If you switch the rear output setting to **Subwoofer**, you can connect a rear speaker lead directly to a subwoofer without using an auxiliary amp. Initially, the unit is set for rear full-range speaker connection (**Full**). When rear output is connected to full range speakers (when **Full** is selected), you can connect other full range speakers (**Rear**) or a subwoofer (**Subwoofer**) to the RCA rear output.

- When the multi-channel processor (DEQ-P7650/DEQ-P6600) is connected to this unit, you cannot operate this function.

### 1 Touch Rear Speaker on the initial menu.

### 2 Touch ◀ or ▶ next to Rear Speaker to switch the rear output setting.

Touch ◀ to select full-range speaker and **Full** appears in the display. Touch ▶ to select subwoofer and **Subwoofer** appears in the display.

- When no subwoofer is connected to the rear output, select **Full** (full-range speaker).
- When a subwoofer is connected to the rear output, select **Subwoofer** (subwoofer).
- When the rear output setting is **Subwoofer**, you cannot operate the following procedure.

### 3 Touch ◀ or ▶ next to Preout to switch the subwoofer output or rear output.

Touching ◀ or ▶ will switch between **Subwoofer** and **Rear** and that status will be displayed.



#### Notes

- Even if you change this setting, there is no output unless you turn the subwoofer output on (refer to *Using subwoofer output* on page 47).
- If you change this setting, subwoofer output in the audio menu will return to the factory settings.
- Both rear speaker lead outputs and RCA rear output are switched simultaneously in this setting. 

## Switching the sound muting/attenuation

Sound from this system is muted or attenuated automatically when the signal from the equipment with mute function is received.

- Sound from this system returns to normal when the muting or attenuation is canceled.

- **Touch TEL on the initial menu to select the setting.**

Touch **TEL** until the desired setting appears in the display.

- **Mute** – Muting
- **ATT-20dB** – Attenuation (**ATT-20dB** has a stronger effect than **ATT-10dB**)
- **ATT-10dB** – Attenuation
- **Off** – Turn the sound muting/attenuation off



#### Notes

- The sound is turned off, **Mute** is displayed and no audio adjustments are possible.
- The sound is attenuated, **ATT** is displayed and no audio adjustments, except volume control, are possible.
- Operation returns to normal when the phone connection is ended. 

## Initial Settings

### Setting the TV signal

When this unit is connected to a TV tuner, you need to adjust the TV signal suitable to your country TV signal setting.

- This function is initially set to **Auto** so that this unit automatically adjusts the TV signal setting.
- About your country TV signal, consult with your nearest Pioneer dealer.
- Only when a Pioneer TV tuner (e.g. GEX-P5750TV(P)) is connected to this unit, you can operate this function.

#### ● Touch TV Signal on the initial menu to select an appropriate TV signal.

Touching **TV Signal** switches TV signal settings in the following order:

**Auto—PAL—NTSC—PAL-M—SECAM** 

### Entering PIN code for Bluetooth wireless connection

To connect your cellular phone to this unit via Bluetooth wireless technology, you need to enter PIN code on your phone to verify the connection. The default code is **0000**, but you can change this in this function.

- With some Bluetooth audio players, you may be required to enter the Bluetooth audio player PIN code in advance to set this unit for a connection.
- You can only operate this function when Bluetooth adapter (e.g. CD-BTB100) is connected to this unit.

#### 1 Touch PIN Code Input on the initial menu.

PIN code input display appears.

#### 2 Touch 0 to 9 to input the PIN code of your Bluetooth audio player.

- To cancel the inputted numbers, touch **C**.

#### 3 After inputting PIN code (up to 16 digits), touch **↵**.

The PIN code you entered is stored in this system. 

### Correcting distorted sound

You can minimize distortion that may be caused by the equalizer curve settings. Setting an equalizer level high can cause distortion. If high sound is crippled or distorted, try switching to **Low**. Normally, leave the setting at **High** to ensure quality sound.

- Only when the multi-channel processor (DEQ-P7650/DEQ-P6600) is connected to this unit, you can operate this function.

#### ● Touch Digital ATT on the initial menu to switch the digital attenuator setting.

Touch **Digital ATT** repeatedly until the desired setting appears in the display.

- **High** – High quality sound
- **Low** – Minimize distortion sound 

### Auto TA and EQ (auto-time alignment and auto-equalizing)

The auto-time alignment is automatically adjusted for the distance between each speaker and the listening position.

The auto-equalizer automatically measures the car interior acoustic characteristics, and then creates the auto-equalizer curve based on that information.

- Only when the multi-channel processor (DEQ-P7650/DEQ-P6600) is connected to this unit, you can operate this function.

Please see the following section for Auto TA and EQ operation. Refer to *Auto TA and EQ (auto-time alignment and auto-equalizing)* on page 85 

## Resetting the audio functions

You can reset all audio functions except volume.

- Only when the multi-channel processor (DEQ-P7650/DEQ-P6600) is connected to this unit, you can operate this function.

**1 Touch Audio Reset on the initial menu.**

**2 Touch Reset.**

**3 Touch Reset again to reset audio functions.**

- To cancel resetting the audio functions, touch **Cancel**. 

## System settings

### Introduction of system adjustments

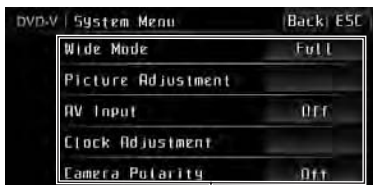

#### ① System menu display

Shows the system function names.

#### 1 Touch AV Menu and then touch System Menu to display the system function names.

The system function names are displayed and operable ones are highlighted.

#### 2 Touch ESC to return to the display of each source.

- To return to the previous display, touch **Back**.

### Changing the wide screen mode

You can select a desired mode for enlarging a 4:3 picture to a 16:9 one.

#### 1 Touch Wide Mode on the system menu.

#### 2 Touch the desired wide mode setting.

##### Full (full)

A 4:3 picture is enlarged in the horizontal direction only, giving you a 4:3 TV picture (normal picture) without any omissions.

##### Just (just)

The picture is enlarged slightly at the center and the amount of enlargement increases horizontally to the ends, enabling you to enjoy a 4:3 picture

without sensing any disparity even on a wide screen.

##### Cinema (cinema)

The picture is enlarged by the same proportion as **Full** or **Zoom** in the horizontal direction and by an intermediate proportion between **Full** and **Zoom** in the vertical direction; ideal for a cinema-sized picture (wide screen picture) where captions lie outside.

##### Zoom (zoom)

A 4:3 picture is enlarged in the same proportion both vertically and horizontally; ideal for a cinema-sized picture (wide screen picture).

##### Normal (normal)

A 4:3 picture is displayed as it is, giving you no sense of disparity since its proportions are the same as that of the normal picture.



#### Notes

- Different settings can be memorized for each video source.
- When video is viewed in a wide screen mode that does not match its original aspect ratio, it may appear different.
- Remember that using the wide mode feature of this system for commercial or public viewing purposes may constitute an infringement on the author's rights protected by the Copyright Law.
- The video image will appear coarser when viewed in **Cinema** or **Zoom** mode.

## Changing the picture adjustment

You can adjust the **Brightness** (brightness), **Contrast** (contrast), **Color** (color), **Hue** (hue), **Dimmer** (dimmer), **Temperature** (temperature) and **Black Level** (black level) for each source and rear view camera.

- You cannot adjust **Color**, **Hue**, **Contrast** and **Black Level** for the audio source.

### 1 Touch Picture Adjustment on the system menu.

The adjustment function names are displayed.

### 2 Touch any of the following touch panel keys to select the function to be adjusted.

To switch between groups of touch panel keys, touch **NEXT** or **PREV**.

- **Brightness** – Adjusts the black intensity
- **Contrast** – Adjusts the contrast
- **Color** – Adjusts the color saturation
- **Hue** – Adjusts the tone of color (red is emphasized or green is emphasized)
- **Dimmer** – Adjust the brightness of display
- **Temperature** – Adjusts the color temperature, resulting in a better white balance
- **Black Level** – Emphasizes dark portion on images so that the difference between brightness and darkness becomes more distinct
- **Rear View/Source** – Switch the picture adjustment modes
  - You cannot adjust the picture adjustment for rear view camera when **Camera Polarity** is set to **Off**. (Refer to *Setting for rear view camera (back up camera)* on the next page.)
  - If color system is set to PAL/PAL-M/SECAM, you cannot adjust **Hue**.
  - With some rear view cameras, picture adjustment may not be possible.

### 3 Touch ◀ or ▶ to adjust the selected item.

Each time you touch ◀ or ▶ it increases or decreases the level of selected item. **+24** to **-24**

is displayed as the level is increased or decreased.

- **Temperature** can be adjusted from **+3** to **-3**.
- **Black Level** can be set on or off.

## Adjusting the dimmer

To prevent the display from being too bright at night, the display is automatically dimmed when the car's headlights are turned on. You can turn the dimmer on or off.

### 1 Touch Picture Adjustment on the system menu.

The adjustment function names are displayed.

### 2 Touch NEXT.

### 3 Touch Dimmer.

### 4 Touch ◀ or ▶ to adjust the brightness.

Each time you touch ◀ or ▶ it moves cursor towards the left or the right.

The level indicates the brightness of the screen being adjusted. The farther the cursor moves to the right, the brighter the screen becomes.

## Setting the AV input

You can switch the setting according to the connected component.

- Select **Video** to watch video of a connected component as **AV** source.
- Select **EXT-Video** to watch video of a connected video unit as **EXT** source.
- Select **TV** to watch TV pictures from a connected TV tuner as **TV** source.
- **Touch AV Input on the system menu to select the AV input setting.**
  - **Off** – No video component connected
  - **Video** – External video component (such as portable video player)
  - **EXT-Video** – External video unit (such as Pioneer products available in the future)
  - **TV** – TV tuner connected with RCA cable

## System settings

### Setting the clock

Use these instructions to set the clock.

#### 1 Touch Clock Adjustment on the system menu.

#### 2 Touch On/Off to turn the clock display on.

- To turn the clock display off, touch **On/Off** again.

#### 3 Touch ◀ or ▶ to select the segment of the clock display you wish to set.

Each time you touch ◀ or ▶ it will select one segment of the clock display:

Hour—Minute

As you select segments of the clock display the segment selected will be highlighted.

#### 4 Touch ▲ or ▼ to put a clock right.



#### Notes

- You can match the clock to a time signal by touching **Just**.
  - If **00** to **29**, the minutes are rounded down. (e.g., **10:18** becomes **10:00**.)
  - If **30** to **59**, the minutes are rounded up. (e.g., **10:36** becomes **11:00**.)
- Even when the sources are off, the clock display appears on the display. 

### Setting for rear view camera (back up camera)



#### CAUTION

**Pioneer recommends the use of a camera which outputs mirror reversed images, otherwise screen image may appear reversed.**

This unit features a function that automatically switches to the rear view camera video (**V IN** jack) when a rear view camera is installed on your vehicle. When the gear shift is in **REVERSE (R)** position, the video automatically

switches to a rear view camera video. (For more details, consult your dealer.)

- After you set up the rear view camera setting, move the gear shift in **REVERSE (R)** and confirm if a rear view camera video can be shown on the display.
- If the display should be switched to a rear view camera video by error while you are driving forward, change the rear view camera setting.
- To end watching a rear view camera video and return to the source display, press and hold **MUTE**.
- Even while driving, rear view camera image can be displayed. To do this, touch **RearView** source icon. In this case, touch **RearView** again to turn off the rear view camera. For details, refer to *Selecting a source* on page 14.
- **Touch Camera Polarity on the system menu to select an appropriate setting.**
  - **Battery** – When the polarity of the connected lead is positive while the gear shift is in **REVERSE (R)** position
  - **Ground** – When the polarity of the connected lead is negative while the gear shift is in **REVERSE (R)** position
  - **Off** – When a rear view camera is not connected to this unit. 

## Introduction of entertainment settings

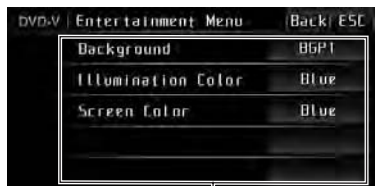

### ① Entertainment menu display

Shows the entertainment function names.

#### 1 Touch AV Menu and then touch Entertainment Menu to display the entertainment function names.

The entertainment function names are displayed and operable ones are highlighted.

#### 2 Touch ESC to return to the display of each source.

- To return to the previous display, touch Back.

## Selecting the background display

You can switch background displays while listening to each source.

#### 1 Touch Background on the entertainment menu.

#### 2 Touch the desired setting.

You can select one from the following list.

- **BGP1** – Background picture 1
- **BGP2** – Background picture 2
- **BGP3** – Background picture 3
- **BGP4** – Background picture 4
- **BGV1** – Background visual 1
- **BGV2** – Background visual 2
- **BGV3** – Background visual 3
- **Photo** – JPEG image stored in this unit

- **AV Input** – Video image from the external video unit that is connected to this unit
  - When the AV (AV input) is not set to **Video**, **AV Input** cannot be selected. (Refer to page 58.)
  - If no JPEG image has been stored in this unit, you cannot select **Photo**. To store JPEG image in this unit, see the following section. Refer to *Capture an image in JPEG files* on page 37.

## Selecting the illumination color

This unit is equipped with multiple-color illumination.

### Direct selection from preset illumination color

You can select an illumination color from the color list.

#### 1 Touch Illumination Color on the entertainment menu.

#### 2 Touch one of the color list.

You can select one from the following list.

- **Blue** (blue)
- **Red** (red)
- **Amber** (amber)
- **Green** (green)
- **White** (white)
- **Scan** (scanning all colors)



#### Notes

- **Scan** setting cycles continuously through all the colors.
- While scanning all colors, touching **Scan** can stop the scanning. When this is done, you can select the displayed color as the background.

## Customizing the illumination color

#### 1 Touch Illumination Color on the entertainment menu.

## Entertainment settings

- 2 Touch **Custom** to display the customizing menu.
- 3 Press **+/- (VOL)** to customize the color.
- 4 To store the customized color in memory, touch and hold one of preset keys (**Memo1, Memo2 or Memo3**) until the beep sounds.

The customized color has been stored in memory.

The next time you touch the same preset key, the color is recalled from memory. 

### Selecting the OSD color

You can change the OSD color.

- 1 Touch **Screen Color** on the entertainment menu.
- 2 Touch one of the color list.

You can select one from the following list.

- **Blue** (blue)
- **Red** (red)
- **Amber** (amber)
- **Green** (green)
- **White** (white) 

## Setting remote control code type

When the remote control operation switch is set to **DVD**, changing the remote control code type enables you to operate the Pioneer DVD player with the supplied remote control. There are three remote codes, code type **A**, code type **B** and code type **AVH**. However, when operating this unit, use the code type **AVH** only.

- With this unit, code **A** and **B** cannot be used.

### 1 Set the remote control selection switch on the left side of the remote control to the appropriate position with a pen tip or other pointed instrument .

- If you select **AVH** mode, there is no need to take the following procedure.
- If you select **A/B** mode, take the following procedure and change the code type to the appropriate type.

### 2 Press 0 and CLEAR on the remote control simultaneously to change the code type.

Initially, the code type is set to **A**. Each time you press **0** and **CLEAR** simultaneously on the remote control the code type switches between **A** and **B**. 

## Adjusting the response positions of the touch panels (Touch Panel Calibration)

If you feel that the touch panel keys on the screen deviate from the actual positions that respond to your touch, adjust the response positions of the touch panel. There are two adjustment methods: 4-point adjustment, in which you touch four corners of the screen; and 16-point adjustment, in which you make fine-adjustments on the entire screen.

- Make sure to use the supplied pen for adjustment, and gently touch the screen. If you press the touch panel forcefully, the

touch panel may be damaged. Do not use a sharp pointed tool such as ballpoint pen or a mechanical pen. Otherwise the screen is damaged.

- If touch panel adjustment cannot be performed properly, consult your local Pioneer dealer.

### 1 Touch the source icon and then touch Off to turn this unit off.

- When the source icon is not displayed, you can display it by touching the screen.

### 2 Press and hold (eject).

The 4-point touch panel adjustment screen appears.

### 3 Touch each of the arrows on the four corners of the screen with the touch panel adjustment pen.

- To cancel the adjustment, press and hold **MUTE**.

### 4 Press DISP OFF to complete the 4-point adjustment.

The adjusted position data is saved.

- Do not turn off the engine while saving the adjusted position data.

### 5 Press DISP OFF to proceed to the 16-point adjustment.

The 16-point touch panel adjustment screen appears.

- To cancel the adjustment, press and hold **MUTE**.

### 6 Gently touch the center of the + mark displayed on the screen with the touch panel adjustment pen.

After you touch all the marks, the adjusted position data is saved.

- Do not turn off the engine while saving the adjusted position data.

### 7 Press and hold MUTE to complete the adjustment.

## Other Functions

### Using the AUX source

A separately sold auxiliary device such as VCR or portable device can be connected to this unit. When connected, auxiliary device is automatically recognized as AUX source and assigned to **AUX**.

### About AUX connection method

You have two methods to connect auxiliary device to this unit.

#### Mini pin plug cable (AUX-1)

*When connecting auxiliary device using a mini plug cable*

- iPod and portable audio/video player can be connected to this unit via mini plug cable.
- If an iPod with video capabilities is connected to this unit via 3.5 mm plug (4 pole) cable (e.g., CD-V150M), you can enjoy the video contents of the iPod.
  - It is possible to connect a portable audio/video player by using a 3.5 mm plug (4 pole) to RCA cable, which is sold separately. However, depending on the cable, reverse connection between red (right side audio) cable and yellow (video) cable is required. Otherwise, audio and video may not be correctly reproduced.

- **Insert the stereo mini plug into the AUX input jack on this unit.**

For more details, refer to *What's what* on page 10.

#### IP-BUS-RCA interconnector (AUX-2)

*When connecting auxiliary device using an IP-BUS-RCA Interconnector (sold separately)*

- **Use an IP-BUS-RCA Interconnector such as the CD-RB20/CD-RB10 (sold separately) to connect this unit to auxiliary device featuring RCA output.**

For more details, refer to the IP-BUS-RCA Interconnector owner's manual.

- You can only make this type of connection if the auxiliary device has RCA outputs.

### Selecting AUX as the source

- **Touch the source icon and then touch AUX-1/AUX-2 to select AUX as the source.**
  - If the auxiliary setting is not turned on, **AUX** cannot be selected. For more details, refer to *Switching the auxiliary setting* on page 53.

### Setting the AUX title

The title displayed for the **AUX** source can be changed.

- Each title can be up to 10 characters long.

- 1 After you have selected AUX as the source, touch AV Menu and Function Menu and then touch Name Edit.**

- When the touch panel keys are not displayed, you can display them by touching the screen.

- 2 Touch ABC to select the desired character type.**

Touch **ABC** repeatedly to switch between the following character types:

- Alphabet (upper case)—Alphabet (lower case)
  - You can select to input numbers and symbols by touching **123**.

- 3 Touch ▲ or ▼ to select a letter of the alphabet.**

- 4 Touch ◀ or ▶ to move the cursor.**

- 5 Touch OK to store the entered title in memory.**

- 6 Touch ESC to return to the ordinary display.** 

## Using the external unit

External unit refers to a Pioneer product (such as ones available in the future) that, although incompatible as a source, enables control of basic functions with this unit. Two external units can be controlled with this unit. When two external units are connected, the external unit is automatically allocated to external unit 1 or external unit 2 by this unit.

Basic operations of the external unit are explained below. Allocated functions are different depending on the connected external unit. For details concerning functions, refer to external unit's owner's manual.

### Selecting the external unit as the source

- Touch the source icon and then touch **EXT-1/EXT-2** to select external unit as the source.

### Basic operation

Functions allocated to the following operations are different depending on the connected external unit. For details concerning functions, refer to the connected external unit's owner's manual.

- Touch **Band**.
- Keep touching **Band**.
- Touch ◀ or ▶.
- Keep touching ◀ or ▶.
- Touch ▲ or ▼.

### Using the functions allocated to 1 to 6 keys

- 1 Touch **NEXT**.
- 2 Touch any of 1 to 6 to select a function.

## Advanced operations

- 1 Touch **AV Menu** and then touch **Function Menu** to display the function names.

The function names are displayed and operable ones are highlighted.

- **Function1** (function 1)
- **Function2** (function 2)
- **Function3** (function 3)
- **Function4** (function 4)
- **Auto/Manual** (auto/manual)

- 2 Touch **ESC** to return to the ordinary display.

- To return to the previous display, touch **Back**. 

### Using the PGM button

You can operate the preprogrammed functions for each source by using **PGM** on the remote control.

- Press **PGM** to turn pause on when selecting the following sources:

- **Disc** – Built-in DVD player
- **iPod** – iPod
- **USB** – USB portable audio player/USB memory
- **M-CD** – Multi-CD player
- **BT Audio** – Bluetooth audio player
- To turn pause off, press **PGM** again.

- Press **PGM** and hold to turn **BSM** on when selecting **Radio** as the source.

Press **PGM** and hold until the **BSM** turns on.

- To cancel the storage process, press **PGM** again.

- Press **PGM** and hold to turn **BSSM** on when selecting **TV** as the source.

Press **PGM** and hold until the **BSSM** turns on.

- To cancel the storage process, press **PGM** again. 

## Available accessories

### Multi-CD Player

#### Listening to a CD

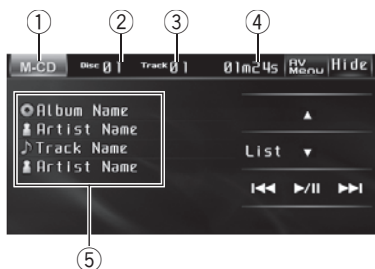

You can use this unit to control a multi-CD player, which is sold separately.

- Only functions described in this section can be operated.
- Only functions described in this manual are supported by 50-disc multi-CD players.
- Only 12 disc title can be displayed even if the 50-disc multi-CD player is connected to this unit.

#### ① Source icon

Shows which source has been selected.

#### ② Disc number indicator

Shows the number of the disc playing.

#### ③ Track number indicator

Shows the number of the track playing.

#### ④ Play time indicator

Shows the elapsed playing time of the current track.

#### ⑤ Title indicator

Shows the disc title and disc artist name of the currently playing disc only when playing CD TEXT discs.

Also, shows the track title and track artist name of the currently playing track only when playing CD TEXT discs.

#### 1 Touch the source icon and then touch M-CD to select the multi-CD player.

#### 2 Touch ▲ or ▼ to select a disc.

#### 3 To skip back or forward to another track, briefly touch I◀◀ or ▶▶I.

Touching ▶▶I skips to the start of the next track. Touching I◀◀ once skips to the start of the current track. Touching it again will skip to the previous track.

- You can also skip back or forward to another track by pressing ◀ or ▶ (TRK).

#### 4 To perform fast forward or reverse, keep touching I◀◀ or ▶▶I.

- You can also perform fast reverse/fast forward by pressing and holding ◀ or ▶ (TRK).

#### Notes

- When multi-CD player completes preparatory operations, **Ready** is displayed.
- If an error message is displayed, refer to the multi-CD player owner's manual.
- If there are no discs in the multi-CD player magazine, **No Disc** is displayed.

### Pausing CD playback

Pause lets you temporarily stop disc playback.

#### ● Touch ▶/II to turn pause on.

Playback of the current track pauses.

- To turn pause off, touch ▶/II again.

### Selecting discs from the disc title list

Disc title list lets you see the list of disc titles and select one of them to playback.

#### 1 Touch List to display the disc list.

#### 2 Touch your favorite disc title (track title).

- To return to the disc list, touch **Back**.
- If no title is entered for a disc, **No Title** is displayed.

#### 3 Touch ESC to return to the ordinary display.

## Introduction to advanced operations

You can only use these functions with a multi-CD player that supports them.

### 1 Touch AV Menu and then touch Function Menu to display the function names.

The function names are displayed and operable ones are highlighted.

### 2 Touch ESC to return to the playback display.

- To return to the previous display, touch **Back**.

## Function and operation

**Repeat**, **Random** and **Scan** operations are basically the same as that of the built-in DVD player.

Function name	Operation
<b>Repeat</b>	Refer to <i>Repeating play</i> on page 31. However, the repeat play ranges you can select are different from that of the built-in DVD player. The repeat play ranges of the multi-CD player are: <ul style="list-style-type: none"> <li>• <b>Multi-CD</b> – Repeat all discs in the multi-CD player</li> <li>• <b>Track</b> – Repeat just the current track</li> <li>• <b>Disc</b> – Repeat the current disc</li> </ul>
<b>Random</b>	Refer to <i>Playing tracks in random order</i> on page 31.
<b>Scan</b>	Refer to <i>Scanning tracks of a CD</i> on page 31. While you are using <b>Disc</b> , the beginning of each track on the selected disc plays for about 10 seconds. When you are using <b>Multi-CD</b> , the beginning of the first track of each disc is played for about 10 seconds.

## Notes

- If you select other discs during repeat play, the repeat play range changes to **Multi-CD**.

- If you perform track search or fast forward/reverse during **Track**, the repeat play range changes to **Disc**.
- After track or disc scanning is finished, normal playback of the tracks begins again.
- If the multi-CD player does not support COMP/DBE, you cannot operate this function.

## Using compression and bass emphasis

You can only use these functions with a multi-CD player that supports them.

COMP (compression) and DBE (dynamic bass emphasis) functions lets you adjust the sound playback quality of the multi-CD player.

### ● Touch Compression on the function menu to select your favorite setting.

Touch **Compression** repeatedly to switch between the following settings:

**Off—COMP1—COMP2—Off—DBE 1—DBE 2**

- If the multi-CD player does not support COMP/DBE, you cannot operate this function. 

## Available accessories

### Bluetooth Audio

#### Basic Operations

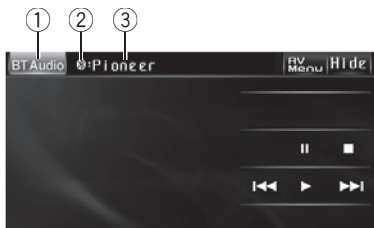

- If you connect a Bluetooth adapter (e.g. CD-BTB100) to this unit, you can control Bluetooth audio players via Bluetooth wireless technology.
- In some countries, CD-BTB100 is not sold on the market.

#### Important

- Depending on the Bluetooth audio player connected to this unit, the operations available with this unit are limited to the following two levels:
  - A2DP profile (Advanced Audio Distribution Profile): Only playing back songs on your audio player is possible.
  - AVRCP profile (Audio/Video Remote Control Profile): Playing back, pausing, selecting songs, etc., are possible.
- Since there are a number of Bluetooth audio players available on the market, operations with your Bluetooth audio player using this unit vary extensively. Refer to the instruction manual that came with your Bluetooth audio player as well as this manual while operating your player on this unit.
- Information about songs (e.g. the elapsed playing time, song title, song index, etc.) cannot be displayed on this unit.
- While you are listening to songs on your Bluetooth audio player, refrain from using on your cellular phone as much as possible. If you use your cellular phone, the signal from your cel-

lular phone may cause noise on the song playback.

- When you are talking on a cellular phone connected to this unit via Bluetooth wireless technology, song playback from your Bluetooth audio player connected to this unit is muted.
- Even if you are listening to a song on your Bluetooth audio player and you switch to another source, song playback continues.

For details concerning operation, refer to the Bluetooth adapter's operation manual. This section provides brief information on Bluetooth audio player operations with this unit, which slightly differs or is abbreviated from that described in the Bluetooth adapter's operation manual.

- Even though your audio player does not contain a Bluetooth module, you can still control it from this unit via Bluetooth wireless technology. To control your audio player using this unit, connect a product featuring Bluetooth wireless technology (available on the market) to your audio player and connect the Bluetooth adapter (e.g. CD-BTB100) to this unit.

#### ① Source icon

Shows which source has been selected.

#### ② Connection indicator

Shows the Bluetooth wireless connection status.

#### ③ Device name

Shows the device name of the connected Bluetooth audio player (or Bluetooth adapter).

### 1 Touch the source icon and then touch BT Audio to select the Bluetooth audio source.

- For this unit to control your Bluetooth audio player it needs to establish a Bluetooth wireless connection. (Refer to *Connecting a Bluetooth audio player* on the next page.)

**2 Touch ▶.**

Playback starts.

**3 To skip back or forward to another track, briefly touch I◀◀ or ▶▶I.**

- You can also skip back or forward to another track by pressing ◀ or ▶ (TRK).

**4 To perform fast forward or reverse, keep touching I◀◀ or ▶▶I.**

- You can also perform fast reverse/fast forward by pressing and holding ◀ or ▶ (TRK).

**5 To stop playback, touch ■.****Pausing playback**● **Touch II during playback.**

- To resume playback at the same point that you turned pause on, touch ▶.

**Introduction to advanced operations****1 Touch AV Menu and then touch Function Menu to display the function names.**

The function names are displayed and operable ones are highlighted.

**2 Touch ESC to return to the ordinary display.**

- To return to the previous display, touch **Back**.

**Connecting a Bluetooth audio player**● **Touch Connection Open on the function menu to turn the connection open on.**

**Connection Waiting** is displayed. This unit is now on standby for connection from Bluetooth audio player.

If your Bluetooth audio player is set ready for Bluetooth wireless connection, connection to this unit is automatically established.

**Note**

Before you can use audio players you may need to enter the PIN code into this unit. If your player requires a PIN code to establish a connection, look for the code on the player or in its accompanying documentation. Refer to *Entering PIN code for Bluetooth wireless connection* on page 55.

**Disconnecting a Bluetooth audio player**● **Touch Disconnect on the function menu.**

After the disconnection is completed, **No Connection** is displayed.

**Displaying BD (Bluetooth Device) information**● **Touch Device Information on the function menu to display the BD address.**

Various information regarding the Bluetooth wireless technology are displayed.

- **Device Name** (device name of this system)
- **BD Address** (address of Bluetooth device)
- **System Version** (system version)
- **BT Module Version** (version of Bluetooth module) 

## Available accessories

# Bluetooth Telephone

## Basic Operations

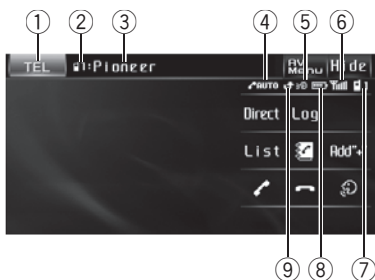

- If you use a Bluetooth adapter (e.g. CD-BTB100), you can connect a cellular phone featuring Bluetooth wireless technology to this unit for hands-free, wireless calls, even while driving.
- In some countries, CD-BTB100 is not sold on the market.



### Important

- Since this unit is on standby to connect with your cellular phone via Bluetooth wireless technology, using this unit without running the engine can result in battery drainage.
- Advanced operations that require your attention such as dialing numbers on the monitor, using phone book, etc., are prohibited while you are driving. When you need to use these advanced operations, stop your vehicle in a safe place.

#### ① Source icon

Shows which source has been selected.

#### ② User number indicator

Shows the registration number of the cellular phone.

#### ③ Device name

Shows the device name of the cellular phone.

#### ④ Automatic answering/Automatic rejecting indicator

Shows when the automatic answering function is on (for more details, refer to *Setting automatic answering* on page 75).

Shows when the automatic rejecting function is on (for more details, refer to *Setting automatic rejecting* on page 75).

#### ⑤ Voice recognition indicator

Shows when the voice recognition function is on (for more details, refer to *Voice recognition* on the next page).

#### ⑥ Signal level indicator

Shows the signal strength of cellular phone.

- The level shown on the indicator may differ from the actual signal level.
- Depending on the cellular phones featuring Bluetooth wireless technology, radio field intensity is not available. In this case, the signal level indicator does not appear.
- If your cellular phone is out of service,  $\nabla \times$  is displayed.

#### ⑦ Telephone indicator

Shows when a phone connection using Bluetooth wireless technology is established (for more details, refer to *Connecting a cellular phone* on page 71).

- While connecting automatically, telephone indicator is flashing.

#### ⑧ Battery strength indicator

Shows the battery strength of cellular phone.

- The level shown on the indicator may differ from the actual battery strength.
- If the battery strength is not available, nothing is displayed in the battery strength indicator area.

#### ⑨ Incoming call notice indication

Shows when an incoming call has been received and not checked yet.

- Incoming call notice is not displayed for calls made when your cellular phone is disconnected from this unit.

For details concerning operation, refer to the Bluetooth adapter's operation manual. This section provides brief information on the hands-free phoning operations with this unit which slightly differs or is cut short from that described in the Bluetooth adapter's operation manual.

- This unit is not compatible with registration for guest phone.

- This unit does not have the name edit function of a Phone Book entry.
- **Touch the source icon and then touch TEL to select the telephone.**

**Note**

The equalizer curve for the phone source is fixed. When selecting the phone source, you cannot perform the operation in the following section. Refer to *Using the equalizer* on page 46. When the multi-channel processor is connected to this unit, you can operate the equalizer function even when selecting the phone source. Refer to *Recalling equalizer curves* on page 84.

**Setting up for hands-free phoning**

Before you can use the hands-free phoning function you must set up the unit for use with your cellular phone. This entails establishing a Bluetooth wireless connection between this unit and your phone, registering your phone with this unit, and adjusting the volume level.

**1 Connection**

For detailed instructions on connecting your phone to this unit via Bluetooth wireless technology, refer to *Connecting a cellular phone* on the next page.

- Your phone should now be temporarily connected. However, to make best use of the technology, we recommend you register the phone to this unit.

**2 Registration**

To register your temporarily connected phone, refer to *Registering a connected cellular phone* on the next page.

**3 Volume adjustment**

Adjust the earpiece volume on your cellular phone for comfort. When adjusted, the volume level is recorded in this unit as the default setting.

- Caller's voice volume and ring volume may vary depending on the type of cellular phone.
- If the difference between the ring volume and caller's voice volume is big, overall volume level may become unstable.
- Before disconnecting the cellular phone from this unit, make sure to adjust the volume to a

proper level. If the volume is muted (zero level) on your cellular phone, the volume level of your cellular phone remains muted even after the cellular phone is disconnected.

**Making a phone call****Voice recognition****1 Touch  to turn the voice recognition function on.**

Voice dial icon appears on the information bar. Voice recognition function is now ready.

- To cancel the voice recognition function, touch  again.

**2 Pronounce the name of your contact.****Taking a phone call****Answering an incoming call****1 When a call comes in, touch .**

- You can also perform the same operation by pressing **◀ (TRK)**.
- If private mode is selected on the cellular phone, hands-free phoning may not be performed.

**2 To end the call, touch .**

- You can also perform the same operation by pressing **▶ (TRK)**.

**Rejecting an incoming call****● When a call comes in, touch .**

The call is rejected.

- You can also perform the same operation by pressing **▶ (TRK)**.

**Answering a call waiting****1 Touch  to answer a call waiting.**

- You can also perform the same operation by pressing **◀ (TRK)**.

**2 Touch  to end all calls.**

- The caller you have been talking to is now on hold. To end the call, both you and your caller need to hang up the phone.
- While your callers hold the line, touching  switches between callers.

## Available accessories

- You can also perform the same operation by pressing ► (TRK).

### Rejecting call waiting

- **Touch ↶ to reject a call waiting.**
  - You can also perform the same operation by pressing ► (TRK).

## Introduction to advanced operations

### 1 Touch AV Menu and then touch Function Menu to display the function names.

The function names are displayed and operable ones are highlighted.

### 2 Touch ESC to return to the telephone standby display.

- To return to the previous display, touch **Back**.

## Connecting a cellular phone

### Searching for available cellular phones

#### 1 Touch Phone Connect on the function menu.

#### 2 Touch Search to search for available cellular phones.

While searching, **Searching** flashes. When available cellular phones featuring Bluetooth wireless technology are found, device name or **Name Not Found** (if names cannot be obtained) is displayed.

- If this unit fails to find any available cellular phones, **Not Found** is displayed.
  - You can display the BD address by touching **BD ADDR**. To return to the device name, touch **Phone Name**.

#### 3 Touch the device name you want to connect.

While connecting, **Connecting** flashes. To complete the connection, check the device name (**Pioneer BT unit**) and enter the link code on your cellular phone.

- Up to five peripheral cellular phones are displayed.
- PIN code is set to **0000** as the default. You can change this code in the initial setting. Refer

to *Entering PIN code for Bluetooth wireless connection* on page 55.

## Using a cellular phone to initiate a connection

### 1 Touch Phone Connect on the function menu.

### 2 Touch Connection Open.

**Connection Waiting** flashes and the unit is now on standby for connection from a cellular phone.

### 3 Use cellular phone to connect to this unit.

- To cancel this function, touch **Connection Open** again.
- PIN code is set to **0000** as the default. You can change this code in the initial setting. Refer to *Entering PIN code for Bluetooth wireless connection* on page 55.

## Disconnecting a cellular phone

### 1 Touch Phone Connect on the function menu.

### 2 Touch Disconnect to disconnect the currently connected cellular phone from this unit.

After disconnection is completed, **No Connection** is displayed.

## Registering a connected cellular phone

### 1 Touch Phone Register on the function menu.

Registration assignments for user phone 1, 2 and 3 appear on the display.

### 2 Touch and hold one of the registration assignments to register the currently connected phone.

If the registration is succeeded, the device name of the connected phone is displayed in the selected assignment.

- If the assignment is empty, the device name is not displayed. If the assignment is already taken, the device name appears. To replace an assignment with a new phone, first delete the current assignment. For more detailed instructions, see *Deleting a registered phone* on this page.
- If the registration failed, device name of the connected phone is not displayed in the selected assignment. In this case, return to step 1 and try again.

## Deleting a registered phone

**1 Touch Phone Register on the function menu.**

**2 Touch Delete next to the device name you want to delete.**

A confirmation display appears. Touch **OK** to delete the phone.

- To cancel deleting a registered phone, touch **Cancel**.

## Connecting to a registered cellular phone

### Connecting to a registered phone manually

**1 Touch Phone Connect on the function menu.**

**2 Touch Direct Connect.**

**3 Touch the device name you want to connect.**

While connecting, **Connecting** is flashing.

- If connection fails, **Connection Error** is displayed.

### Connecting to a registered phone automatically

● **Touch Auto Connect on the function menu to turn the Automatic Connection function on.**

If your cellular phone is ready for Bluetooth wireless connection, connection to this unit is automatically established.

- To turn automatic connection off, touch **Auto Connect** again.

## Using the phone book

### Transferring entries to the phone book

The Phone Book can hold a total of 500 entries. 300 from User 1, 150 from User 2, and 50 from User 3.

**1 Touch Phone Book Transfer on the function menu.**

**2 Touch Start to turn the Phone Book Transfer function on.**

The Phone Book Transfer is now on standby.

**3 Use the cellular phone to perform phone book transfer.**

Perform phone book transfer using the cellular phone. For detailed instructions, refer to the instruction manual that came with your cellular phone.

- The display indicates how many entries have been transferred and the total number to be transferred.
- To cancel the transferring process, touch **Stop**.

**4 When you are done transferring Phone Book entries, touch ESC.**



#### Note

When the phone book transfer is complete, the connection to your cellular phone is off. To use the Phone Book, connect to your cellular phone once again, referring to *Connecting to a registered cellular phone* on this page.

### Changing the phone book display order

● **Touch Phone Book Name View on the function menu to change the name view order.**

**Inverted** is displayed and the name view order is changed.

- To change to the original order (**Original**), touch **Phone Book Name View** again.



### Calling a number in the phone book



#### Important

Be sure to park your vehicle and apply the parking brake when performing this operation.

## Available accessories

- 1 Touch  to display the Phone Book.
- 2 Touch  or  to select the first letter of the name you are looking for.

- 3 Touch **Enter** to show entries starting with the letter you chose.

The display shows the first six Phone Book entries starting with that letter (e.g. “Ben”, “Brian” and “Burt” when “B” is selected).

- To refine the search with a different letter, touch **Clear**.

- 4 Touch a Phone Book entry you want to call.

The display is switched to the Phone Book detail display.

- 5 Touch phone number of the Phone Book entry you want to call.

If several phone numbers are entered to an entry, touch one you want to call.

The display returns to the normal display and the Phone Book entry you selected is displayed on the information bar.

- 6 Touch  to make a call.

- For an international call, touch **Add “+”** to add **+** to the phone number.

- 7 To end the call, touch .

### Editing phone numbers

#### Important

Be sure to park your vehicle and apply the parking brake when performing this operation.

You can edit the numbers of Phone Book entries. Each phone number can be up to 24 digits long.

- 1 Touch  to display the Phone Book.
- 2 Select a Phone Book entry you want to edit.

Please see Steps 2 to 4 of the following section for how to do this. Refer to *Calling a number in the phone book* on the previous page.

- 3 Touch **Edit** next to the phone number you want to edit.

The display is changed to the Phone Book dial edit display.

- 4 Touch **0** to **9** to input numbers.

- For an international call, touch **Add “+”** to add **+** to the phone number.
- Touch **Clear** to delete the number. Touch and hold **Clear** to delete all the input numbers.

- 5 Touch **OK** to store the new number.

### Clearing a phone book entry

#### Important

Be sure to park your vehicle and apply the parking brake when performing this operation.

- 1 Touch  to display the Phone Book.
- 2 Select a Phone Book entry you want to delete.

Please see Steps 2 to 4 of the following section for how to do this. Refer to *Calling a number in the phone book* on the previous page.

- 3 Touch **Delete** to delete the Phone Book entry.

A confirmation display appears. Touch **Yes** to delete the entry.

- If you do not want to clear a Phone Book entry that you have selected, touch **No**.

### Using the call history

#### Important

Be sure to park your vehicle and apply the parking brake when performing this operation.

The 6 most recent calls made (dialed), received and missed, are stored in the Call History. You can browse the Call History and call numbers from it.

- 1 Touch **Log** to display the Call History.

Touching **Log** repeatedly switches between the following call histories:

**Missed Calls** (missed call)—**Dialed Calls** (dialed call)—**Received Calls** (received call)

- You can switch between phone number and name (if entered) by touching **ABC/123**.
- If no phone numbers have been stored in the selected list, nothing is displayed.

## Available accessories

### 2 Touch a phone number or name (if entered) you want to call.

The display returns to the normal display and the phone number you selected is displayed on the information bar.

### 3 Touch to make a call.

- For an international call, touch **Add “+”** to add + to the phone number.

### 4 To end the call, touch .

## Using preset numbers



### Important

Be sure to park your vehicle and apply the parking brake when performing this operation.

## Assigning preset numbers

Numbers that you dial frequently can be assigned to presets for quick recall.

You can assign up to 6 frequently called phone numbers to number presets.

### 1 Select a desired phone number from the phone book or the call history. Or directly enter a desired phone number.

To select a desired phone number from the Phone Book or the Call History, see the instructions explained in previous pages. To directly enter a desired phone number, please see the following section. Refer to *Making a call by entering phone number* on this page. The display should now be the normal display and the selected phone number is displayed on the information bar.

### 2 Touch List to display preset assignments.

Preset assignments appear in the display (if not displayed yet).

### 3 Keep touching one of preset assignments to store the phone number.

The phone number you selected is stored in presets.

- No Data** is displayed for empty assignment. Even if the assignment is taken, you can replace it to the new one by keeping touching the assignment.

## Recalling preset numbers

### 1 Touch List to display preset assignments.

Preset assignments appear in the display (if not displayed yet).

### 2 Touch one of preset assignments.

The selected phone number should now be displayed on the information bar.

### 3 Touch to make a call.

### 4 To end the call, touch .

## Making a call by entering phone number



### Important

Be sure to park your vehicle and apply the parking brake when performing this operation.

### 1 Touch Direct to display the direct dial display.

### 2 Touch 0 to 9 to input numbers.

- For an international call, touch **Add “+”** to add + to the phone number.
- Touch **Clear** to delete the number. Touch and hold **Clear** to delete all the input numbers.
- Up to 24 digits can be entered.
- If you want to store the entered phone number to preset assignment, touch **Set** here. The display returns to the normal display and the phone number you entered is selected.

### 3 When you completed entering the number, touch to make a call.

### 4 To end the call, touch .

## Clearing memory

### 1 Touch Clear Memory on the function menu.

### 2 Touch Clear next to the item you want to delete from the memory.

Select from the following:

- Phone Book** (phone book)
- Dialed Calls** (dialed call history)
- Received Calls** (received call history)
- Missed Calls** (missed call history)

## Available accessories

- **Dial Preset** (preset phone numbers)

After selecting a desired item, a confirmation display appears. Touch **OK** to delete the memory.

- If you do not want to clear memory that you have selected, touch **Cancel**.
- If you want to clear all the Phone Book, dialed/received/missed call history list and preset phone number, touch **Clear All**.

### Setting automatic answering

- **Touch Auto Answer on the function menu to turn the automatic answer on.**

- To turn the automatic answer off, touch **Auto Answer** again.

### Setting automatic rejecting

- **Touch Refuse All Calls to turn the automatic call rejection on.**

- To turn the automatic call rejection off, touch **Refuse All Calls** again.

### Switching the ring tone

- **Touch Ring Tone to turn the ring tone on.**

- To turn the ring tone off, touch **Ring Tone** again.

### Echo canceling and noise reduction

- **Touch Echo Cancel to turn Echo Cancel function on.**

- To turn echo canceling off, touch **Echo Cancel** again.

### Displaying BD (Bluetooth Device) address

#### Displaying BD address of this system

- **Touch Device Information to display the BD address.**

Various information regarding the Bluetooth wireless technology are displayed.

- **Device Name** (device name of this system)
- **BD Address** (address of Bluetooth device)

- **System Version** (version of this unit's microprocessor)

- **BT Module Version** (version of Bluetooth module)

### Displaying BD address of your cellular phone

#### 1 Touch Phone Connect on the function menu.

#### 2 Touch BD Address to display the BD address.

12-digit hexadecimal string is displayed.

- To return to the device name, touch **Phone Name**. 

## TV tuner

### Basic Operations

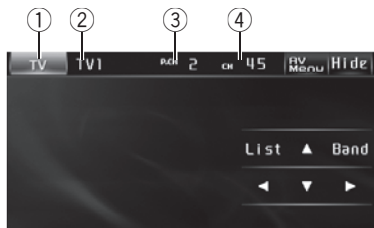

You can use this unit to control a TV tuner (e.g. GEX-P5750TV(P)), which is sold separately. For details concerning operation, refer to the TV tuner's operation manual. This section provides information on TV operations with this unit, which differs from that described in the TV tuner's operation manual.

- ① **Source icon**  
Shows which source has been selected.
- ② **Band indicator**  
Shows which band the TV tuner is tuned to.
- ③ **Preset number indicator**  
Shows which preset has been selected.
- ④ **Channel indicator**  
Shows which channel the TV tuner is tuned to.

#### 1 Touch the source icon and then touch TV to select the TV.

- When the source icon is not displayed, you can display it by touching the screen.

#### 2 Touch the screen to display the touch panel keys.

#### 3 Touch Band to select a band.

Touch **Band** repeatedly until the desired band is displayed, **TV1** or **TV2**.

#### 4 To perform manual tuning, briefly touch ◀ or ▶.

- You can also perform manual tuning by pressing ◀ or ▶ (**TRK**).

#### 5 To perform seek tuning, keep touching ◀ or ▶ for about one second and release.

The tuner will scan the channels until a broadcast strong enough for good reception is found.

- You can cancel seek tuning by briefly touching either ◀ or ▶.
- If you keep touching ◀ or ▶ you can skip broadcasting channels. Seek tuning starts as soon as you release the keys.
- You can also perform seek tuning by pressing and holding ◀ or ▶ (**TRK**).

## Storing and recalling broadcast stations

You can easily store up to 12 broadcast stations for later recall.

- Six stations for each band can be stored in memory.

#### 1 Touch List to display the preset list.

#### 2 When you find a station that you want to store in memory, keep touching one of preset tuning keys P01 to P12 until the beep sounds.

The selected broadcast station has been stored in memory.

The next time you touch the same preset tuning key the station is recalled from memory.

- When **P01** to **P06** and **P07** to **P12** are not displayed, you can display them by touching **List**.
- To switch between **P01** to **P06** and **P07** to **P12**, touch ▲ or ▼.

## Introduction to advanced operations

#### 1 Touch AV Menu and then touch Function Menu to display the function names.

The function names are displayed and operable ones are highlighted.

#### 2 Touch ESC to return to the TV picture.

- To return to the previous display, touch **Back**.

## Available accessories

### Storing the strongest broadcast stations sequentially

- **Touch BSSM on the function menu to turn BSSM on.**

**BSSM** begins to flash. While **BSSM** is flashing the 12 strongest broadcast stations will be stored in order from the lowest channel up. When finished, **BSSM** stops flashing.

- To cancel the storage process, touch **BSSM** again.



#### Note

Storing broadcast stations with BSSM may replace broadcast stations you have saved using **P01** to **P12**.

### Selecting the area group

- 1 **Touch Country on the function menu.**

- 2 **Touch ◀ or ▶ to select the area group.**

Touch ◀ or ▶ until the desired area group appears in the display.

**Country1** (CCIR channel)—**Country2** (IN channel)—**Country3** (CHN channel)—

**Country4** (U.K. channel)—**Country5** (OIRT channel)—**Country6** (AUSTRALIA channel)—**Country7** (SAF channel)

### Digital Signal Processor Introduction of DSP adjustments

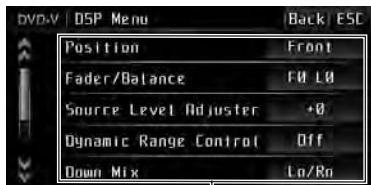

You can use this unit to control multi-channel processor (DEQ-P7650/DEQ-P6600), which is sold separately.

- ① **DSP display**

Shows the DSP function names.

By carrying out the following settings/adjustments in the order shown, you can create a finely-tuned sound field effortlessly.

- 1 *Setting the speaker setting*
- 2 *Using the position selector*
- 3 *Auto TA and EQ (auto-time alignment and auto-equalizing)*
- 4 *Adjusting the time alignment*
- 5 *Adjusting the speaker output levels using a test tone*
- 6 *Selecting a cross-over frequency*
- 7 *Adjusting the speaker output levels*
- 8 *Adjusting 3-band parametric equalizer*

- 1 **Touch AV Menu and then touch DSP Menu to display the DSP function names.**

The DSP function names are displayed and operable ones are highlighted.

- To go to the next group of function names, touch ▼.
- To return to the previous group of function names, touch ▲.
- When playing discs recorded with more than 96 kHz sampling frequency, you cannot use audio functions. Also, equalizer curve setting, **Position**, **Auto EQ** and **Auto TA** will be canceled.

- When playing discs recorded with more than 96 kHz sampling frequency, audio is outputted from front speakers only.
- When selecting FM as the source, you cannot switch to **Source Level Adjuster**.
- When playing other than the DVD disc, you cannot switch to **Dynamic Range Control**.
- When neither **Front-L** nor **Front-R** is selected in **Position**, you cannot switch to

#### Time Alignment

- When both the center speaker and the rear speaker are set to OFF in the speaker setting, you cannot switch to **Dolby Pro Logic II**.

### 2 Touch ESC to return to the ordinary display.

- To return to the previous display, touch **Back**.

## Using the position selector

One way to assure a more natural sound is to accurately position the stereo image, putting you right in the center of the sound field. The position selector function lets you automatically adjust the speaker output levels and inserts a delay time to match the number and position of occupied seats. When used in conjunction with the SFC, the feature will make the sound image more natural and offer a panoramic sound that envelops you.

### 1 Touch Position on the DSP function menu.

### 2 Touch ◀/▶/▲/▼ to select a listening position.

Touch one of these, ◀/▶/▲/▼, to select a listening position as listed in the table.

Key	Display	Position
◀	Front-L	Front seat left
▶	Front-R	Front seat right
▲	Front	Front seats
▼	All	All seats

- To cancel the selected listening position, touch the same key again.



#### Note

When you make adjustments to the listening position, the speaker outputs are automatically set for appropriate levels. You can tailor the levels more precisely referring to *Adjusting the speaker output levels using a test tone* or *Adjusting the speaker output levels*.

## Using balance adjustment

You can change the fader/balance setting so that it can provide the ideal listening environment in all occupied seats.

### 1 Touch Fader/Balance on the DSP function menu.

### 2 Touch ▲ or ▼ to adjust front/rear speaker balance.

Each time you touch ▲ or ▼ it moves the front/rear speaker balance towards the front or the rear.

**Front:25** to **Rear:25** is displayed as the front/rear speaker balance moves from front to rear.

- **FR: 0/LR: 0** is the proper setting when only two speakers are used.

### 3 Touch ◀ or ▶ to adjust left/right speaker balance.

Each time you touch ◀ or ▶ it moves the left/right speaker balance towards the left or the right.

**Left:25** to **Right:25** is displayed as the left/right speaker balance moves from left to right.

## Using the sound field control

The SFC function creates the sensation of a live performance.

## Available accessories

- The acoustics of different performance environments are not the same and depend on the extent and contour of space through which sound waves move and on how sounds bounce off the stage, walls, floors and ceilings. At a live performance you hear music in three stages: direct sound, early reflections, and late reflections, or reverberations. Those factors are programmed into the SFC circuitry to recreate the acoustics of various performance settings.

### ● Touch SFC on the DSP function menu to select the setting.

Touch **SFC** until the desired setting appears in the display.

**Musical—Drama—Action—Jazz—Hall—Club—Off**

Display	Setting
Musical	Musical
Drama	Drama
Action	Action
Jazz	Jazz
Hall	Hall
Club	Club
Off	Off

### Note

If the source is a 2-channel LPCM audio or a 2-channel Dolby Digital audio and you select SFC effects that are most applicable for 5.1-channel audio (i.e., **Musical**, **Drama** or **Action**), we recommend turning Dolby Pro Logic II on. On the other hand, when selecting SFC effects that are intended for use with 2-channel audio (i.e., **Jazz**, **Hall** or **Club**), we recommend turning Dolby Pro Logic II off.

## Adjusting source levels

SLA (source level adjustment) lets you adjust the volume level of each source to prevent radical changes in volume when switching between sources.

- Settings are based on the FM volume level, which remains unchanged.

### 1 Compare the FM volume level with the level of the source you wish to adjust.

### 2 Touch Source Level Adjuster on the DSP function menu.

### 3 Touch ◀ or ▶ to adjust the source volume.

Each time you touch ◀ or ▶ it increases or decreases the source volume.

**+4** to **-4** is displayed as the source volume is increased or decreased.

### Notes

- The AM volume level can also be adjusted with source level adjustments.
- Video CD, CD, compressed audio and DivX are set to the same source level adjustment volume automatically.
- External unit 1 and external unit 2 are set to the same source level adjustment volume automatically.
- AUX (auxiliary input) and AV (AV input) are set to the same source level adjustment volume automatically.

## Using the dynamic range control

The dynamic range refers to the difference between the largest and softest sounds. The dynamic range control compresses this difference so that you can clearly hear sounds even at low volume levels.

- The dynamic range control is effective only on Dolby Digital sounds.
- When playing other than the DVD disc, you cannot switch to **Dynamic Range Control**.

## Available accessories

1 Touch **Dynamic Range Control** on the **DSP** function menu.

2 Touch **▶** to turn the dynamic range control on.

- To turn dynamic range control off, touch **◀**.

### Using the down-mix function

The down-mix function allows you to play back multi-channel audio in 2 channels.

1 Touch **Down Mix** on the **DSP** function menu.

2 Touch **◀** or **▶** to select the desired level.

- **Lo/Ro** – Stereo mix the original audio that do not contain channel modes such as surround components.
- **Lt/Rt** – Down mix so that the surround components can be restored (decoded).

### Using the direct control

You can override audio settings to check for effectiveness of your audio settings.

- All audio functions are locked out when the direct control is on except **VOL** and **Dolby Pro Logic II**.

1 Touch **Digital Direct** on the **DSP** function menu.

2 Touch **▶** to turn the direct control on.

- To turn direct control off, touch **◀**.

### Using the Dolby Pro Logic II

Dolby Pro Logic II creates five full-bandwidth output channels from two-channel sources to achieve high-purity matrix surround.

- Dolby Pro Logic II supports up to 48 kHz sampling rate stereo source and has no effect on other types of source.
- When both the center speaker and the rear speaker are set to **OFF** in the speaker setting, you cannot switch to **Dolby Pro Logic II**.

1 Touch **Dolby Pro Logic II**.

2 Touch any of the following touch panel keys to select the desired mode.

- **Movie** – The Movie mode suitable for movie playback
  - **Music** – The Music mode suitable for music playback
  - **Matrix** – The Matrix mode for when FM radio reception is weak
  - **Off** – Turn Dolby Pro Logic II off
  - **Music Adjust** – Adjust the Music mode
- You can operate **Music Adjust** only when **Music** has been selected.

### Adjusting the Music mode

You can adjust the Music mode with the following three controls.

- **Panorama (Panorama)** extends the front stereo image to include the surround speakers for an exciting “wraparound” effect.
- **Dimension (Dimension)** allows you to gradually adjust the sound field either towards the front or the rear.
- **Center Width Control (Center Width)** allows center-channel sounds to be positioned between the center speaker and the left/right speakers. It improves the left-center-right stage presentation for both the driver and the front passenger.

1 Touch **Dolby Pro Logic II**.

2 Touch **Music** and then touch **Music Adjust**.

- You can operate **Music Adjust** only when **Music** has been selected.

3 Touch **▲** or **▼** to select **Panorama (panorama)**.

Each time you touch **▲** or **▼** selects the item in the following order:

**Panorama** (panorama)—**Dimension** (dimension)—**Center Width** (center width)

## Available accessories

### 4 Touch ► to turn the panorama control on.

- To turn the panorama control off, touch ◀.

### 5 Touch ▼ to select Dimension and then touch ◀ or ► to adjust front/rear speaker balance.

Each time you touch ◀ or ► it moves the sound towards the front or the rear.

**+3** to **-3** is displayed as the front/rear speaker balance moves from front to rear.

### 6 Touch ▼ to select Center Width and then touch ◀ or ► to adjust the center image.

Each time you touch ◀ or ► it gradually spreads the center channel sound into the front left and right speakers over a range **0** to **7**.

**3** is the default and it's recommended for most recordings. **0** places all center sound in the center speaker. **7** places all center sound equally in the left/right speakers.

## Setting the speaker setting

You need to make with/without (or yes/no) and size (bass reproducing capacity) selection/adjustments depending on the installed speakers. The size needs to be set to **Large** (large) if the speaker is capable of reproducing sounds of about 100 Hz or below. Otherwise select **Small** (small).

- Low frequency range is not output if the subwoofer is set to **Off** and the front and rear speakers set to **Small** or **Off**.
- It is imperative that non-installed speakers be set to **Off**.
- Set the front or rear speaker to **Large** if the speaker is capable of reproducing bass content, or if no subwoofer is installed.

### 1 Touch Speaker Setting.

### 2 Touch ▲ or ▼ to select the speaker to be adjusted.

Each time you touch ▲ or ▼ selects the speaker in the following order:

**Front** (front speakers)—**Center** (center speaker)—**Rear** (rear speakers)—**Subwoofer** (subwoofer)—**Phase** (subwoofer setting)

- You can switch to **Phase** only when the subwoofer has been set to **On**.

### 3 Touch ◀ or ► to select the correct size for the selected speaker.

Each time you touch ◀ or ► selects the size in the following order:

**Off** (off)—**Small** (small)—**Large** (large)

- You cannot select **Off**, when **Front** (front speakers) have been selected.
- You can select **On** or **Off**, when **Subwoofer** (subwoofer) has been selected.
- You can switch **Reverse** (reverse phase) or **Normal** (normal phase), when **Phase** (subwoofer setting) has been selected.

## Correcting the subwoofer's phase

If trying to boost the bass output of the subwoofer doesn't do much or rather makes you feel that the bass gets more murky, this may indicate that the subwoofer's output and bass content you hear over other speakers cancel each other out. To remove this problem, try changing the phase setting for the subwoofer.

### 1 Touch Speaker Setting.

### 2 Touch ▲ or ▼ to select Subwoofer (subwoofer).

Each time you touch ▲ or ▼ selects the speaker in the following order:

**Front** (front speakers)—**Center** (center speaker)—**Rear** (rear speakers)—**Subwoofer** (subwoofer)—**Phase** (subwoofer setting)

### 3 Touch ► to turn subwoofer output on.

- To turn subwoofer output off, touch ◀.

### 4 Touch ▼ and then touch ◀ or ► to select the phase of subwoofer output.

Touch ► to select normal phase and **Normal** appears in the display. Touch ◀ to select reverse phase and **Reverse** appears in the display.

 **Note**

When playing a 2-channel mono source with Dolby Pro Logic II turned on, there may be occasions when the following will occur:

- No audio is outputted if the center speaker setting is **Small** or **Large** and no center speaker is installed.
- Audio is heard only over the center speaker if installed and the center speaker setting is **Small** or **Large**.

## Adjusting the speaker output levels

Speaker level can be adjusted finely by listening to an audio output. First, use test tone to adjust the approximate speaker level, and then use this function to adjust finely.

### 1 Touch Speaker Level.

#### 2 Touch ▲ or ▼ to select the speaker to be adjusted.

Each time you touch ▲ or ▼ selects the speaker in the following order:

**Front-L** (front speaker left)—**Center** (center speaker)—**Front-R** (front speaker right)—**Rear-R** (rear speaker right)—**Rear-L** (rear speaker left)—**Subwoofer** (subwoofer)

- You cannot select speakers whose size is set to **Off**. (Refer to *Setting the speaker setting* on the previous page.)

#### 3 Touch ◀ or ▶ to adjust the speaker output level.

Each time you touch ◀ or ▶ it increases or decreases the equalizer level. **+10** to **-10** is displayed as the level is increased or decreased.

 **Note**

To adjust the speaker output levels in this mode is the same as making the speaker output levels at **Test Tone**. Both provide the same results.

## Selecting a cross-over frequency

You can select a frequency, under which sounds are reproduced through the subwoofer. If the installed speakers include one whose size has been set to **Small**, you can select a frequency, under which sounds are reproduced through a **Large** speaker or subwoofer.

### 1 Touch Cross Over.

#### 2 Touch ▲ or ▼ to select the speaker to be adjusted.

Each time you touch ▲ or ▼ selects the speaker in the following order:

**Front** (front speakers)—**Center** (center speaker)—**Rear** (rear speakers)—**Subwoofer** (subwoofer)

#### 3 Touch ◀ or ▶ to select cross-over frequency.

Each time you touch ◀ or ▶ selects cross-over frequencies in the following order:

**63Hz—80Hz—100Hz—125Hz—160Hz—200Hz**

 **Note**

Selecting a cross-over frequency is to set a cross-over frequency of the subwoofer's L.P.F. (low-pass filter) and that of the **Small** speaker H.P.F. (high-pass filter). The cross-over frequency setting has no effect if the subwoofer is set to **Off** and other speakers are set to **Large** or **Off**.

## Adjusting the speaker output levels using a test tone

This function allows you to easily get the overall balance right among the speakers.

### 1 Touch Test Tone.

## Available accessories

### 2 Touch Start to start the test tone output.

The test tone is outputted. It rotates from speaker to speaker in the following sequence at intervals of about two seconds. The current settings for the speaker over which you hear the test tone are shown in the display.

**Front-L** (front speaker left)—**Center** (center speaker)—**Front-R** (front speaker right)—

**Rear-R** (rear speaker right)—**Rear-L** (rear speaker left)—**Subwoofer** (subwoofer)

Check each speaker output level. If no adjustments are needed, perform step 4 to stop the test tone.

- The settings do not appear for speakers whose size is set to **Off**. (Refer to *Setting the speaker setting* on page 81.)

### 3 Touch ◀ or ▶ to adjust the speaker output level.

Each time you touch ◀ or ▶ it increases or decreases the equalizer level. **+10** to **-10** is displayed as the level is increased or decreased.

- The test tone rotates to the next speaker after about two seconds from the last operation.

### 4 Touch Stop to stop the test tone output.

#### Notes

- If needed, select speakers and adjust their 'absolute' output levels. (Refer to *Adjusting the speaker output levels* on the previous page.)
- To adjust the speaker output levels in this mode is the same as making the speaker output levels at **Speaker Level** (speaker output level). Both provide the same results.

## Using the time alignment

The time alignment lets you adjust the distance between each speaker and the listening position.

### 1 Touch Time Alignment.

### 2 Touch any of the following touch panel keys to select the time alignment.

- **Initial** – Initial time alignment (factory setting)
- **Auto TA** – Time alignment created by auto TA and EQ. (Refer to *Auto TA and EQ (auto-time alignment and auto-equalizing)* on page 85.)
- **Custom** – Adjusted time alignment that you can create for yourself
- **Off** – Turn the time alignment off
- **TA Adjust** – Adjust the time alignment as desired
  - You cannot select **Auto TA** if auto TA and EQ has not been carried out.
  - You cannot select **TA Adjust** when neither **Front-L** nor **Front-R** is selected in **Position**.

### Adjusting the time alignment

You can adjust the distance between each speaker and the selected position.

- An adjusted time alignment is memorized in **Custom**.

### 1 Touch Time Alignment and then touch TA Adjust.

- You cannot select **TA Adjust** when neither **Front-L** nor **Front-R** is selected in **Position**.

### 2 Touch ▲ or ▼ to select the speaker to be adjusted.

Each time you touch ▲ or ▼ selects the speaker in the following order:

**Front-L** (front speaker left)—**Center** (center speaker)—**Front-R** (front speaker right)—**Rear-R** (rear speaker right)—**Rear-L** (rear speaker left)—**Subwoofer** (subwoofer)

- You cannot select speakers whose size is set to **Off**. (Refer to *Setting the speaker setting* on page 81.)

### 3 Touch ◀ or ▶ to adjust the distance between the selected speaker and the listening position.

Each time you touch ◀ or ▶ increases or decreases the distance. **0.0cm** to **500.0cm** is displayed as the distance is increased or decreased.

## Using the equalizer

The equalizer lets you adjust the equalization to match the car's interior acoustic characteristics as desired.

### Recalling equalizer curves

There are seven stored equalizer curves which you can easily recall at any time. Here is a list of the equalizer curves.

Display	Equalizer curve
Powerful	Powerful
Natural	Natural
Vocal	Vocal
Flat	Flat
Custom1	Custom 1
Custom2	Custom 2
Super Bass	Super bass

- **Custom1** and **Custom2** are adjusted equalizer curves.
- When **Flat** is selected, no supplement or correction is made to the sound. This is useful to check the effect of the equalizer curves by switching alternatively between **Flat** and a set equalizer curve.

#### 1 Touch Parametric EQ.

#### 2 Touch ▲ or ▼ to select the desired item.

Each time you touch ▲ or ▼ selects the item in the following order:

**Equalizer** (equalizer)—**SP-Select** (speakers)—**Band** (bands)—**Frequency** (center frequency)—**Level** (equalizer level)—**Q. Factor** (Q factor)

#### 3 Touch ▶ to select the equalizer.

Touch ▶ repeatedly to switch between the following equalizers:

**Powerful—Natural—Vocal—Flat—Custom1—Custom2—Super Bass**

### Adjusting 3-band parametric equalizer

For **Custom1** and **Custom2** equalizer curves, you can adjust the front, rear and center equalizer curves separately by selecting a center frequency, an equalizer level and a Q factor for each band.

- A separate **Custom1** curve can be created for each source.
- A **Custom2** curve can be created common to all sources.
- The center speaker largely determines the sound image and getting the balance right isn't easy. We recommend reproducing a 2-ch. audio (a CD for example) and getting the balance right among the speakers except for the center, and then reproducing a 5.1-ch. audio (Dolby Digital or DTS) and adjusting the center speaker output to the balance you have already got among the other speakers.

#### 1 Touch Parametric EQ.

#### 2 Touch ▲ or ▼ to select the desired item.

Each time you touch ▲ or ▼ selects the item in the following order:

**Equalizer** (equalizer)—**SP-Select** (speakers)—**Band** (bands)—**Frequency** (center frequency)—**Level** (equalizer level)—**Q. Factor** (Q factor)

#### 3 Touch ▶ to select the equalizer.

Touch ▶ repeatedly to switch between the following equalizers:

**Powerful—Natural—Vocal—Flat—Custom1—Custom2—Super Bass**

#### 4 Touch ▼ and then touch ◀ or ▶ to select the speaker to be adjusted.

Touch ◀ or ▶ until the desired speaker appears in the display.

## Available accessories

**Rear** (rear speakers)—**Center** (center speaker)  
—**Front** (front speakers)

▪ You cannot select speakers whose size is set to **Off**. (Refer to *Setting the speaker setting* on page 81.)

### 5 Touch ▼ and then touch ◀ or ▶ to select the equalizer band to be adjusted.

Each time you touch ◀ or ▶ selects equalizer bands in the following order:

**Low** (low)—**Mid** (mid)—**High** (high)

### 6 Touch ▼ and then touch ◀ or ▶ to select the center frequency of selected band.

Touch ◀ or ▶ until the desired frequency appears in the display.

**40Hz—50Hz—63Hz—80Hz—100Hz—125Hz—160Hz—200Hz—250Hz—315Hz—400Hz—500Hz—630Hz—800Hz—1kHz—1.25kHz—1.6kHz—2kHz—2.5kHz—3.15kHz—4kHz—5kHz—6.3kHz—8kHz—10kHz—12.5kHz**

### 7 Touch ▼ and then touch ◀ or ▶ to adjust the equalizer level.

Each time you touch ◀ or ▶ it increases or decreases the equalizer level. **+12** to **-12** is displayed as the level is increased or decreased.

### 8 Touch ▼ and then touch ◀ or ▶ to select the desired Q factor.

Each time you touch ◀ or ▶ switches between the following Q factor:

**Narrow** (narrow)—**Wide** (wide)

▪ You can adjust parameters for each band of the other speakers in the same way.

### **Note**

You can select a center frequency for each band. You can change the center frequency in 1/3-octave steps, but you cannot select frequencies that have intervals shorter than 1 octave among the center frequencies of the three bands.

## Using the auto-equalizer

The auto-equalizer is the equalizer curve created by auto TA and EQ (refer to *Auto TA and EQ (auto-time alignment and auto-equalizing)* on this page).

You can turn the auto-equalizer on or off.

### 1 Touch Auto EQ.

▪ You cannot use this function if auto TA and EQ has not been carried out.

### 2 Touch ▶ to turn the auto-equalizer on.

▪ To turn auto-equalizer off, touch ◀.

## Auto TA and EQ (auto-time alignment and auto-equalizing)

The auto-time alignment is automatically adjusted for the distance between each speaker and the listening position.

The auto-equalizer automatically measures the car interior acoustic characteristics, and then creates the auto-equalizer curve based on that information.

### **WARNING**

To prevent accidents, never carry out auto TA and EQ while driving. When this function measures the car interior acoustic characteristics to create an auto-equalizer curve, a loud measurement tone (noise) may be outputted from the speakers.

### **CAUTION**

- Carrying out auto TA and EQ under the following conditions may damage the speakers. Be sure to check the conditions thoroughly before carrying out auto TA and EQ.
  - When speakers are incorrectly connected. (e.g., When a rear speaker is connected to a subwoofer output.)
  - When a speaker is connected to a power amp delivering output higher than the speaker's maximum input power capability.

- If the microphone is placed in an unsuitable position the measurement tone may become loud and measurement may take a long time, resulting in a drain on battery power. Be sure to place the microphone in the specified location.

### Before operating the auto TA and EQ function

- Carry out auto TA and EQ in as quiet a place as possible, with the car engine and air conditioning switched off. Also cut power to car phones or portable telephones in the car, or remove them from the car before carrying out auto TA and EQ. Sounds other than the measurement tone (surrounding sounds, engine sound, telephones ringing etc.) may prevent correct measurement of the car interior acoustic characteristics.
- Be sure to carry out auto TA and EQ using the supplied microphone. Using another microphone may prevent measurement, or result in incorrect measurement of the car interior acoustic characteristics.
- When front speaker is not connected, auto TA and EQ cannot be carried out.
- When this unit is connected to a power amp with input level control, auto TA and EQ may not be possible if you lower power amp input level. Set the power amp's input level to the standard position.
- When this unit is connected to a power amp with an LPF, turn off the LPF on the power amp before carrying out auto TA and EQ. In addition, the cut-off frequency for built-in LPF of an active subwoofer should be set to the highest frequency.
- The time alignment value calculated by auto TA and EQ may differ from the actual distance in the following circumstances. However, the distance has been calculated by computer to be the optimum delay to give accurate results for the circumstances, so please continue to use this value.
  - When the reflected sound within a vehicle is strong and delays occur.
  - When delays occur for low sounds due to the influence of the LPF on active subwoofers or external amps.

- Auto TA and EQ changes the audio settings as below:
  - The fader/balance settings return to the center position. (Refer to page 78.)
  - The equalizer curve switches to **Flat**. (Refer to page 84.)
  - It will be adjusted automatically to high pass filter setting for front, center and rear speaker.
- If you carry out auto TA and EQ when a previous setting of this already exists, the setting will be replaced.

### Carrying out auto TA and EQ

#### 1 Stop the car in a place that is as quiet as possible, close all doors, windows and the sun roof, and then turn the engine off.

If the engine is left running, engine noise may prevent correct auto TA and EQ.

#### 2 Fix the supplied microphone in the center of the headrest of the driver's seat, facing forward, using the belt (sold separately).

The auto TA and EQ may differ depending on where you place the microphone. If desired, place the microphone on the front passenger seat to carry out auto TA and EQ.

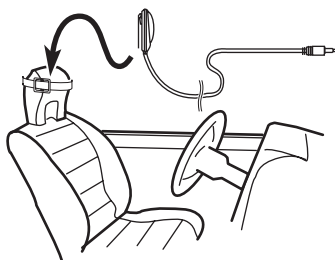

## Available accessories

### 3 Turn the ignition switch to ON or ACC.

If the car's air conditioner or heater is turned on, turn it off. Noise from the fan in the air conditioner or heater may prevent correct auto TA and EQ.

- Press **SRC/OFF** to turn the source on if this unit is turned off.

### 4 Select the position for the seat on which the microphone is placed.

Refer to *Using the position selector* on page 78.

- If no position is selected before you start auto TA and EQ, **Front-L** is selected automatically.

### 5 Touch the source icon and then touch Off to turn this unit off.

### 6 Touch the screen to display the touch panel keys.

### 7 Touch AV Menu and then touch Initial Menu to display the function names.

### 8 Touch Auto EQ&TA to enter the auto TA and EQ measurement mode.

### 9 Plug the microphone into the microphone input jack on the multi-channel processor.

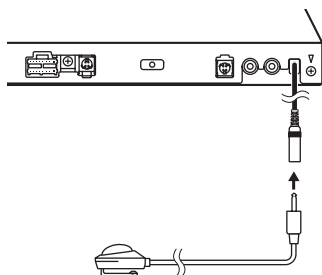

For details concerning operation, refer to the multi-channel processor's operation manual.

### 10 Touch Start to start the auto TA and EQ.

### 11 Get out of the car and close the door within 10 seconds when the 10-second count-down starts.

The measurement tone (noise) is outputted from the speakers, and auto TA and EQ begins.

- When all speakers are connected, auto TA and EQ is completed in about nine minutes.
- To stop auto TA and EQ, touch **Stop**.
- To cancel auto TA and EQ on the way, touch **Back** or **ESC**.

### 12 When auto TA and EQ is completed, Complete is displayed.

When correct measurement of car interior acoustic characteristics is not possible, an error message is displayed. (Refer to *Understanding auto TA and EQ error messages* on page 92.)

### 13 Touch ESC to cancel the auto TA and EQ mode.

### 14 Store the microphone carefully in the glove compartment.

Store the microphone carefully in the glove compartment or any other safe place. If the microphone is subjected to direct sunlight for an extended period, high temperatures may cause distortion, color change or malfunction. 

## Additional Information

### Troubleshooting

#### Common

Symptom	Cause	Action (See)
Power doesn't turn on. The unit doesn't operate.	Leads and connectors are incorrectly connected.	Confirm once more that all connections are correct.
	The fuse is blown.	Rectify the reason for the fuse blowing, then replace the fuse. Be very sure to install a fuse with the same rating.
	Noise and other factors are causing the built-in microprocessor to operate incorrectly.	Press <b>RESET</b> . (Page 8)
Operation with the remote control isn't possible. The unit does not operate correctly even when the appropriate remote control buttons are pressed.	The remote control operation mode is incorrect.	Switch to the correct remote control mode.
	The remote control code is incorrect.	Make sure the remote control selection switch setting and code type setting are the same.
	Battery power is low.	Load new battery.
	Some operations are prohibited with certain discs.	Check by using another disc.
Playback is not possible.	The disc is dirty.	Clean disc. (Page 94)
	The loaded disc is a type this unit cannot play.	Check what type the disc is.
	Non compatible video system disc is loaded.	Change to a disc compatible to your video system.
No sounds are heard. The volume level will not rise.	Cables are not connected correctly.	Connect the cables correctly.
	The unit is performing still, slow motion or frame-by-frame playback.	There is no sound during still, slow motion or frame-by-frame playback.
There is no picture.	The parking brake cord is not connected.	Connect a parking brake cord, and apply the parking brake.
	The parking brake is not applied.	Connect a parking brake cord, and apply the parking brake.
The icon  is displayed, and operation is not possible.	The operation is prohibited for the disc.	This operation is not possible.
	The operation is not compatible with the disc's organization.	This operation is not possible.
The picture stops (pauses) and the unit cannot be operated.	Reading of data has become impossible during playback.	After stopping playback once, start playback once more.
There is no sound. Volume level is low.	The volume level is low.	Adjust the volume level.
	The attenuator is on.	Turn the attenuator off.
There is audio and video skipping.	The unit is not firmly secured.	Secure the unit firmly.
The picture is stretched, the aspect is incorrect.	The aspect setting is incorrect for the display.	Select the appropriate setting for your display. (Page 50)
When the ignition switch is turned ON (or turned to ACC), the motor sounds.	The unit is confirming whether a disc is loaded or not.	This is a normal operation.

## Additional Information

Nothing is displayed. The touch panel keys cannot be used.	The rear view camera is not connected. <b>Camera Polarity</b> is at incorrect setting.	Connect a rear view camera. Press and hold <b>MUTE</b> to return to the source display and then select the correct setting for <b>Camera Polarity</b> . (Page 59)
---	---	--

### Problems during DVD playback

Symptom	Cause	Action (See)
Playback is not possible.	The loaded disc has a different region number from this unit.	Replace the disc with one featuring the same region number as this unit. (Page 7, Page 106)
A parental lock message is displayed and playback is not possible.	Parental lock is on.	Turn parental lock off or change the level. (Page 51)
Parental lock cannot be canceled.	The code number is incorrect. You have forgotten your code number.	Input the correct code number. (Page 51) Touch <b>C</b> 10 times to cancel the code number. (Page 51)
Dialog language (and subtitle language) cannot be switched.	The DVD playing does not feature multiple language recordings. You can only switch between items indicated in the disc menu.	You cannot switch among multiple languages if they are not recorded on the disc. Switch using the disc menu.
No subtitles are displayed.	The DVD playing does not feature subtitles. You can only switch between items indicated in the disc menu.	Subtitles are not displayed if they are not recorded on the disc. Switch using the disc menu.
Playback is not with the audio language and subtitle language settings selected in <b>Setup</b> .	The DVD playing does not feature dialog or subtitles in the language selected in <b>Setup</b> .	Switching to a selected language is not possible if the language selected in <b>Setup</b> is not recorded on the disc.
Switching the viewing angle is not possible.	The DVD playing does not feature scenes shot from multiple angles. You are trying to switch to multiple angle viewing of a scene that is not recorded from multiple angles.	You cannot switch between multiple angles if the DVD does not feature scenes recorded from multiple angles. Switch between multiple angles when watching scenes recorded from multiple angles.
The picture is extremely unclear/distorted and dark during playback.	The disc features a signal to prohibit copying. (Some discs may have this.)	Since this unit is compatible with the copy guard analog copy protect system, when playing a disc that has a signal prohibiting copying, the picture may suffer from horizontal stripes or other imperfections when viewed on some displays. This does not mean this unit is malfunctioning.

### Problems during Video CD playback

Symptom	Cause	Action
The PBC (playback control) menu display cannot be called up.	The Video CD playing does not feature PBC.	This operation is not possible with Video CDs not featuring PBC.
Repeat play and track/time search are not possible.	The Video CD playing features PBC.	This operation is not possible with Video CDs featuring PBC.

## Additional Information

### Problems during iPod playback

Symptom	Cause	Action
iPod doesn't operate correctly.	Cables are incorrectly connected.	Disconnect the cable from iPod. Once iPod main menu is displayed, connect the cable again. Reset the iPod.
	The iPod version is old.	Update the iPod version.

### Problems during multi-channel processor connection

Symptom	Cause	Action (See)
No sounds are heard. The volume level will not rise.	Optical cables are not connected correctly.	Connect the cables correctly.
Even if multi-channel audio is selected, 2-channel audio is output.	Digital output setting is set to <b>Linear PCM</b> .	Normally, set the digital output setting to <b>Stream</b> . (Page 52)



## Error messages

When you contact your dealer or your nearest Pioneer Service Center, be sure to have the error message recorded.

### Built-in DVD player

Message	Cause	Action
<b>Different Region Disc</b>	The disc does not have the same region number as this unit	Replace the DVD video with one bearing the correct region number.
<b>Error-02-XX/FF-FF</b>	Dirty disc	Clean disc.
	Scratched disc	Replace disc.
	The disc is loaded upside down	Check that the disc is loaded correctly.
	Electrical or mechanical	Press <b>RESET</b> .
<b>Unplayable Disc</b>	This type of disc cannot be played by this unit	Replace the disc with one this unit can play.
	The inserted disc does not contain any files that can be played back	Replace disc.
<b>Protect</b>	All the files on the inserted disc are secured by DRM	Replace disc.
<b>Skipped</b>	The inserted disc contains WMA files that are protected by DRM	Replace disc.
<b>Temp</b>	The temperature of this unit is outside the normal operating range	Wait until the unit's temperature returns to within normal operating limits.
<b>Rental Expired.</b>	The inserted disc that contains expired DivX VOD content.	Replace disc.
<b>File Not Playable-High Definition.</b>	The inserted disc contains high definition DivX file.	This unit cannot play DivX HD file. Replace the disc with one this unit can play.

## Additional Information

<b>It is not possible to write it in the flash.</b>	This unit's flash memory used for temporary storage area is full.	Select the playable file.
<b>Authorization Error</b>	This unit's DivX registration code has not been authorized by DivX VOD contents provider.	Register this unit to DivX VOD contents provider. (Page 52)
<b>Unplayable File</b>	This type of file cannot be played by this unit.	Select the playable file.

### USB audio player/USB memory

Message	Cause	Action
<b>Unplayable File</b>	This type of file cannot be played by this unit.	Select the playable file.
	No songs	Transfer the audio files to the USB portable audio player/USB memory and connect.
	USB memory with security enabled is connected	Follow the USB memory instructions to disable the security.
<b>Skipped</b>	The connected USB portable audio player/USB memory contains WMA files that are protected by Windows Media™ DRM 9/10	Play an audio file not protected by Windows Media DRM 9/10.
<b>Protect</b>	All the files on the connected USB portable audio player/USB memory are protected by Windows Media DRM 9/10	Transfer audio files not protected by Windows Media DRM 9/10 to the USB portable audio player/USB memory and connect.
<b>N/A USB</b>	The USB device connected to is not supported by this unit.	Connect a USB portable audio player or USB memory that is USB Mass Storage Class compliant.
	USB device is not formatted with FAT16 or FAT32	USB device should be formatted with FAT16 or FAT32.
<b>Check USB</b>	The USB connector or USB cable is short-circuited.	Confirm that the USB connector or USB cable is not caught in something or damaged.
	The connected USB portable audio player/USB memory consumes more than 500 mA (maximum allowable current).	Disconnect the USB portable audio player/USB memory and do not use it. Turn the ignition switch to OFF, then to ACC or ON and then connect the compliant USB portable audio player/USB memory.
<b>Error-02-9X/-DX</b>	Communication failure	Perform one of the following operations. –Turn the ignition switch OFF and back ON. –Disconnect the USB portable audio player/USB memory. –Change to a different source. Then, return to the USB portable audio player/USB memory.

## Additional Information

### iPod

Message	Cause	Action
<b>Error-02-6X/-9X/-DX</b>	Communication failure	Disconnect the cable from iPod. Once iPod main menu is displayed, connect the cable again. Reset the iPod.
	iPod failure	Disconnect the cable from iPod. Once iPod main menu is displayed, connect the cable again. Reset the iPod.
<b>Error-02-67</b>	Old version of iPod	Update the iPod version.
<b>No Songs</b>	No songs	Transfer the songs to iPod.
<b>Stop</b>	No songs in the current list	Select a list that contains the songs.



## Understanding auto TA and EQ error messages

When correct measurement of car interior acoustic characteristics is not possible using the auto TA and EQ, an error message may appear on the display. If an error message appears, refer to the table below to see what the problem is and the suggested method of correcting the problem. After checking, try again.

Message	Cause	Action
<b>Error. Please check MIC.</b>	Microphone is not connected.	Plug the supplied microphone securely into the jack.
<b>Error. Please check Front speaker., Error. Please check Front-L speaker., Error. Please check Front-R speaker., Error. Please check Center speaker., Error. Please check Rear speaker., Error. Please check Rear-L speaker., Error. Please check Rear-R speaker., Error. Please check Subwoofer.</b>	The microphone cannot pick up the measuring tone of a speaker.	<ul style="list-style-type: none"> <li>• Confirm that the speakers are connected correctly.</li> <li>• Correct the input level setting of the power amp connected to the speakers.</li> <li>• Set the microphone correctly.</li> </ul>
<b>Error. Please check noise.</b>	The surrounding noise level is too high.	<ul style="list-style-type: none"> <li>• Stop your car in a place that is as quiet as possible, and switch off the engine, air conditioner or heater.</li> <li>• Set the microphone correctly.</li> </ul>



## Additional Information

### Understanding messages

Messages	Translation
CAUTION: Screen image may appear reversed.	Pioneer recommends the use of a camera which outputs mirror reversed images, otherwise screen image may appear reversed.



## Additional Information

### Handling guideline of discs and player

- Use only discs featuring any of following logos.

#### DVD video



#### Video CD



#### CD



- Use only normal, round discs. If you insert irregular, non-round, shaped discs they may jam in the DVD player or not play properly.



- Check all discs for cracks, scratches or warping before playing. Discs that have cracks, scratches or are warped may not play properly. Do not use such discs.
- Avoid touching the recorded (non-printed) surface when handling the disc.
- Store discs in their cases when not in use.
- Keep discs out of direct sunlight and do not expose the discs to high temperatures.
- Do not attach labels, write on or apply chemicals to the surface of the discs.
- To clean a disc, wipe the disc with a soft cloth outward from the center.



- If the heater is used in cold weather, condensation may form on components inside the DVD player. Condensation may cause the DVD player to not operate properly. If you think that condensation is a problem turn off the DVD player for an hour or so to allow it to dry out and wipe any damp discs with a soft cloth to remove the moisture.
- Road shocks may interrupt disc playback. ■

### DVD discs

- With some DVD video discs, it may not be possible to use certain functions.
- It may not be possible to play back some DVD video discs.
- It is not possible to play back DVD-ROM/ DVD-RAM discs. ■

## Additional Information

### DVD-R/DVD-RW discs

- Unfinalized DVD-R/-RW discs which have been recorded with the Video format (video mode) cannot be played back.
- It may not be possible to play back DVD-R/DVD-RW discs, because of disc characteristics, scratches or dirt on the disc, or dirt, condensation, etc. on the lens of this unit.
- Playback of discs recorded on a personal computer may not be possible, depending on the application settings and the environment. Please record with the correct format. (For details, contact the manufacturer of the application.)
- DVD-R/-RW discs which have been recorded with the Video Recording format (VR mode) can be played back. However, unfinalized disc may not be played back. Unplayable disc should be finalized. In addition, finalized DVD-R DL (Dual Layer) disc cannot be recorded/edited.
- DVD-R DL (Dual Layer) discs which have been recorded with the Video Recording format (VR mode) can be played back. However, this unit is not compatible with Layer Jump recording mode.
- For more information about recording mode, please contact manufacture of DVD recorder or application.
- The following logo indicates that this unit is compatible with DVD-RW discs which have been recorded with the Video Recording format (VR mode).

**RW**  
COMPATIBLE



### AVCHD recorded discs

- This unit is not compatible with discs recorded in AVCHD (Advanced Video Codec High Definition) format. Do not insert AVCHD discs. If inserted, the disc may not be ejected. 

### CD-R/CD-RW discs

- When CD-R/CD-RW discs are used, playback is possible only for discs which have been finalized.
- It may not be possible to play back CD-R/CD-RW discs recorded on a music CD recorder or a personal computer because of disc characteristics, scratches or dirt on the disc, or dirt, condensation, etc., on the lens of this unit.
- Playback of discs recorded on a personal computer may not be possible, depending on the application settings and the environment. Please record with the correct format. (For details, contact the manufacturer of the application.)
- Playback of CD-R/CD-RW discs may become impossible in case of direct exposure to sunlight, high temperatures, or the storage conditions in the vehicle.
- Titles and other text information recorded on a CD-R/CD-RW disc may not be displayed by this unit (in the case of audio data (CD-DA)).
- Read the precautions with CD-R/CD-RW discs before using them. 

### Dual Discs

- Dual Discs are two-sided discs that have a recordable CD for audio on one side and a recordable DVD for video on the other.
- Playback of the DVD side is possible with this unit. However, since the CD side of Dual Discs is not physically compatible with the general CD standard, it may not be possible to play the CD side with this unit.
- Frequent loading and ejecting of a Dual Disc may result in scratches on the disc. Serious scratches can lead to playback problems on this unit. In some cases, a Dual Disc may become stuck in the disc loading slot and will not eject. To prevent this, we recommend you refrain from using Dual Disc with this unit.
- Please refer to the information from the disc manufacturer for more detailed information about Dual Discs. 

## Additional Information

### Compressed audio compatibility

#### WMA

- Compatible format: WMA encoded by Windows Media Player
- File extension: .wma
- Bit rate: 5 kbps to 320 kbps (CBR), VBR
- Sampling frequency: 8 kHz to 48 kHz
- Windows Media Audio 9 Professional, Lossless, Voice: No

#### MP3

- File extension: .mp3
- Bit rate: 8 kbps to 320 kbps (CBR), VBR
- Sampling frequency: 8 kHz to 48 kHz (32, 44.1, 48 kHz for emphasis)
- Compatible ID3 tag version: 1.0, 1.1, 2.2, 2.3 (ID3 tag Version 2.x is given priority than Version 1.x.)
- M3u playlist: No
- MP3i (MP3 interactive), mp3 PRO: No

#### AAC

- Compatible format: AAC encoded by iTunes
- File extension: .m4a
- Bit rate: 8 kbps to 320 kbps
- Sampling frequency: 8 kHz to 44.1 kHz
- Transmission rate: 16 kbps to 320 kbps
- Apple Lossless: No

### Handling guideline and supplemental information

- There may be a slight delay when starting playback of audio files encoded with image data.
- Only 32 characters from beginning can be displayed as a file name (including the file extension) or a folder name.
- The text information of some audio files may not be correctly displayed.
- This unit may not operate correctly depending on the application used to encode WMA files.

### Compressed audio files on the disc

- ISO 9660 Level 1 and 2 compliant. Romeo and Joliet file systems are both compatible with this player.
- Multi-session playback is possible.
- Compressed audio files are not compatible with packet write data transfer.
- Regardless of the length of blank section between the songs of original recording, compressed audio discs play with a short pause between songs.

### USB audio player/USB memory



#### CAUTION

Pioneer accepts no responsibility for data lost on the USB memory/USB portable audio player even if that data is lost while using this unit.

- This unit can play back files in the USB portable audio player/USB memory that is USB Mass Storage Class. However, copyright protected files that are stored in above-mentioned USB devices cannot be played back.
- You cannot connect a USB portable audio player/USB memory to this unit via a USB hub.
- Partitioned USB memory is not compatible with this unit.
- Depending on the kind of USB portable audio player/USB memory you use, this unit may not recognize the USB audio player/USB memory or audio files may not be played back properly.
- Do not leave the USB portable audio player/USB memory in direct sunlight for extended amounts of time. Extended exposure to direct sunlight can result in USB portable audio player/USB memory malfunction due to the resulting high temperature.
- Do not leave the USB portable audio player/USB memory in high temperature.

## Additional Information

- Firmly secure the USB portable audio player/USB memory when driving. Do not let the USB portable audio player/USB memory fall onto the floor, where it may become jammed under the brake or accelerator pedal.
- Depending on the USB devices connected to this unit, it may generate noise in the radio.
- There may be a slight delay when starting playback of audio files on a USB portable audio player/USB memory with numerous folder hierarchies.
- Do not connect anything other than the USB portable audio player/USB memory.
- Operations may vary depending on the kind of USB audio player and a USB memory. 

### Example of a hierarchy

: Folder

: Compressed audio file

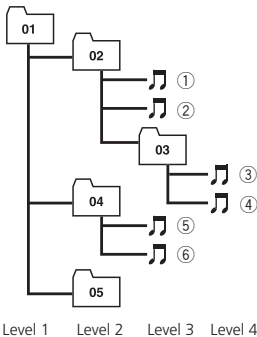

### The sequence of audio files on the disc

- This unit assigns folder numbers. The user cannot assign folder numbers.
- Folder selection sequence or other operation may be altered depending on the encoding or writing software.
- Up to 3 500 files on a DVD (-R/-RW) can be played back.

- Up to 999 files on a CD (-R/-RW) can be played back.
- Up to 700 folders on a disc can be played back.

### The sequence of audio files on USB memory

*For USB portable audio players, the sequence is different from that of USB memory and depends on the player.*

- 01 to 05 represent assigned folder numbers. ① to ⑥ represent the playback sequence. The user cannot assign folder numbers and specify the playback sequence with this unit.
- Playback sequence of the audio file is the same as recorded sequence in the USB device.
- To specify the playback sequence, the following method is recommended.
  - 1 Create the file name including numbers that specify the playback sequence (e.g., 001xxx.mp3 and 099yyy.mp3).
  - 2 Put those files into a folder.
  - 3 Record the folder containing files into the USB device.

However, depending on the system environment, you cannot specify the file playback sequence.

- Up to 65 535 files on a USB portable audio player/USB memory can be played back.
- Up to 6 000 folders on a USB portable audio player/USB memory can be played back. 

### iPod compatibility

- This unit supports only the following iPods. Supported iPod software versions are shown below. Older versions of iPod software may not be supported.
  - iPod nano first generation (software version 1.3.1)
  - iPod nano second generation (software version 1.1.3)
  - iPod nano third generation (software version 1.1.2)

## Additional Information

- iPod fifth generation (software version 1.3.0)
- iPod classic (software version 1.1.2)
- iPod touch (software version 2.0)
- iPhone 3G (software version 2.0)
- iPhone (software version 2.0)
- Depending on the generation or version of the iPod, some functions can not be operated.
- Operations may vary depending on the software version of iPod.
- When using an iPod, iPod Dock Connector to USB Cable is required.
- Pioneer CD-IU50 interface cable is also available. For details, consult your dealer. 

### About handling the iPod

#### CAUTION

- Pioneer accepts no responsibility for data lost on the iPod even if that data is lost while using this unit.
- Do not leave the iPod in direct sunlight for extended amounts of time. Extended exposure to direct sunlight can result in iPod malfunction due to the resulting high temperature.
- Do not leave the iPod in a high temperature.
- Firmly secure the iPod when driving. Do not let the iPod fall onto the floor, where it may become jammed under the brake or accelerator pedal.

For details, refer to the iPod's manuals.

### About iPod settings

- When an iPod is connected, this unit changes the EQ (equalizer) setting of the iPod to Flat in order to optimize the acoustics. When you disconnect the iPod, the EQ returns to the original setting.
- You cannot set Repeat to off on the iPod when using this unit. Even if you set Repeat to off on the iPod, Repeat is automatically changed to All when connecting the iPod to this unit. 

### JPEG picture files

- JPEG is short for Joint Photographic Experts Group and refers to a still image compression technology standard.
- Files are compatible with Baseline JPEG and EXIF 2.1 still image up to resolution of 8 192 × 7 680. (EXIF format is used most commonly with digital still cameras.)
- EXIF format that processed by the personal computer may not be played back.
- There is no progressive JPEG compatibility.

#### Important

- When naming a JPEG picture file, add the corresponding filename extension (.jpg, .jpeg, .jpe or .jfif).
- This unit plays back files with the filename extension (.jpg, .jpeg, .jpe or .jfif) as a JPEG picture file. To prevent malfunctions, do not use these extensions for files other than JPEG picture files. 

### DivX video files

- Depending on the file information composition such as the number of audio stream, there may be a slight delay in the start of playback on discs.
- Some special operation may be prohibited because of the composition of DivX files.
- DivX files downloaded only from DivX partner site are guarantee of proper operation. Unauthorized DivX file may not operate properly.
- DRM rental file cannot be operated until starting playing back.
- This unit corresponds to a DivX file display up to 1 590 minutes 43 seconds. Also, search operation beyond this time limit is prohibited.
- If a file contains more than 4 GB, playback is stopped on the way.
- DivX VOD file playback requires ID code of this unit to DivX VOD provider. About ID code, refer to *Displaying your DivX® VOD registration code* on page 52.

## Additional Information

- For more details about DivX, visit the following site:  
<http://www.divx.com/>

### DivX compatibility

- Compatible format: DivX video format implemented in relation to DivX standards
- File extensions: .avi or .divx
- DivX Ultra format: No
- DivX HD format: No
- DivX files without video data: No
- Compatible audio codec: MP2, MP3, Dolby Digital
- LPCM: No
- Bit rate: 8 kbps to 320 kbps (CBR), VBR
- Sampling frequency: 8 kHz to 48 kHz
- Compatible external subtitle file extension: .srt 

### Using the display correctly

#### CAUTION

- If liquid or foreign matter should get inside this unit, turn off the power immediately and consult your dealer or the nearest authorized PIONEER Service Station. Do not use the unit in this condition because doing so may result in fire, electric shock, or other failure.
- If you notice smoke, a strange noise or smell, or any other abnormal signs from the display, turn off the power immediately and consult your dealer or the nearest authorized PIONEER Service Station. Using this unit in this condition may result in permanent damage to the system.
- Do not disassemble or modify this unit, as there are high-voltage components inside which may cause electric shock. Be sure to consult your dealer or the nearest authorized PIONEER Service Station for internal inspection, adjustments, or repairs.

### Handling the display

- Do not allow direct sunlight to fall on the display when this unit is not being used. Extended exposure to direct sunlight can

result in LCD screen malfunction due to the resulting high temperatures.

- Never touch the screen with anything besides your finger when operating the touch panel function. The screen can scratch easily.
- When the display is subjected to direct sunlight for a long period of time, it will become very hot resulting in possible damage to the LCD screen. You should avoid exposing the display unit to direct sunlight as much as possible.
- The display should be used within the temperature ranges shown below.  
Storage temperature range: -20 °C to +80 °C  
At temperatures higher or lower than the operating temperature range, the display may not operate normally.
- The LCD screen is exposed in order to increase its visibility within the vehicle. Please do not press strongly on it as this may damage it.
- Do not push the LCD screen forcefully as this may scratch it.

### Liquid crystal display (LCD) screen

- Heat from the heater may damage the LCD screen, and cool air from the cooler may cause moisture to form inside the display resulting in possible damage. Also, if the display is cooled down by the cooler, the screen may become dark, or the life span of the small fluorescent tube used inside the display may be shortened.
- Small black dots or white dots (bright dots) may appear on the LCD screen. These are due to the characteristics of the LCD screen and do not indicate a problem with the display.
- At low temperatures, the LCD screen may be dark for a while after the power is turned on.
- The LCD screen will be difficult to see if it is exposed to direct sunlight.

## Additional Information

- When using a portable phone, keep the antenna of the portable phone away from the display to prevent disruption of the video by the appearance of spots, colored stripes, etc.

### Changing the wide screen size

By changing the screen size from 4:3 to 16:9, you can adjust the screen so that the screen can fit to the video image you are playing.

For details concerning operation, refer to *Changing the wide screen mode* on page 57.

### Changing the picture adjustment

You can make the best adjustment to the picture display by the **Brightness**, **Contrast**, **Color** and **Hue**. You can also dim or brighten the overall picture the **Dimmer**.

For details concerning operation, refer to *Changing the picture adjustment* on page 58.

### Keeping the display in good condition

- When removing dust from the screen or cleaning the display, first turn the system power off, then wipe with a soft dry cloth.
- When wiping the screen, take care not to scratch the surface. Do not use harsh or abrasive chemical cleaners.

### Small fluorescent tube

- A small fluorescent tube is used inside the display to illuminate the LCD screen.
  - The fluorescent tube should last for approximately 10 000 hours, depending on operating conditions. (Using the display at low temperatures reduces the service life of the fluorescent tube.)
  - When the fluorescent tube reaches the end of its useful life, the screen will be dark and the image will no longer be projected. If this happens, consult your dealer or the nearest authorized PIONEER Service Station. 

## Additional Information

### Language code chart for DVD

Language (code), input code	Language (code), input code	Language (code), input code
Japanese (ja), <b>1001</b>	Guarani (gn), <b>0714</b>	Pashto, Pushto (ps), <b>1619</b>
English (en), <b>0514</b>	Gujarati (gu), <b>0721</b>	Quechua (qu), <b>1721</b>
French (fr), <b>0618</b>	Hausa (ha), <b>0801</b>	Rhaeto-Romance (rm), <b>1813</b>
Spanish (es), <b>0519</b>	Hindi (hi), <b>0809</b>	Kirundi (rn), <b>1814</b>
German (de), <b>0405</b>	Croatian (hr), <b>0818</b>	Romanian (ro), <b>1815</b>
Italian (it), <b>0920</b>	Hungarian (hu), <b>0821</b>	Kinyarwanda (rw), <b>1823</b>
Chinese (zh), <b>2608</b>	Armenian (hy), <b>0825</b>	Sanskrit (sa), <b>1901</b>
Dutch (nl), <b>1412</b>	Interlingua (ia), <b>0901</b>	Sindhi (sd), <b>1904</b>
Portuguese (pt), <b>1620</b>	Interlingue (ie), <b>0905</b>	Sangho (sg), <b>1907</b>
Swedish (sv), <b>1922</b>	Inupiak (ik), <b>0911</b>	Serbo-Croatian (sh), <b>1908</b>
Russian (ru), <b>1821</b>	Indonesian (in), <b>0914</b>	Sinhalese (si), <b>1909</b>
Korean (ko), <b>1115</b>	Icelandic (is), <b>0919</b>	Slovak (sk), <b>1911</b>
Greek (el), <b>0512</b>	Hebrew (iw), <b>0923</b>	Slovenian (sl), <b>1912</b>
Afar (aa), <b>0101</b>	Yiddish (ji), <b>1009</b>	Samoa (sm), <b>1913</b>
Abkhazian (ab), <b>0102</b>	Javanese (jw), <b>1023</b>	Shona (sn), <b>1914</b>
Afrikaans (af), <b>0106</b>	Georgian (ka), <b>1101</b>	Somali (so), <b>1915</b>
Amharic (am), <b>0113</b>	Kazakh (kk), <b>1111</b>	Albanian (sq), <b>1917</b>
Arabic (ar), <b>0118</b>	Greenlandic (kl), <b>1112</b>	Serbian (sr), <b>1918</b>
Assamese (as), <b>0119</b>	Cambodian (km), <b>1113</b>	Siswati (ss), <b>1919</b>
Aymara (ay), <b>0125</b>	Kannada (kn), <b>1114</b>	Sesotho (st), <b>1920</b>
Azerbaijani (az), <b>0126</b>	Kashmiri (ks), <b>1119</b>	Sundanese (su), <b>1921</b>
Bashkir (ba), <b>0201</b>	Kurdish (ku), <b>1121</b>	Swahili (sw), <b>1923</b>
Byelorussian (be), <b>0205</b>	Kirghiz (ky), <b>1125</b>	Tamil (ta), <b>2001</b>
Bulgarian (bg), <b>0207</b>	Latin (la), <b>1201</b>	Telugu (te), <b>2005</b>
Bihari (bh), <b>0208</b>	Lingala (ln), <b>1214</b>	Tajik (tg), <b>2007</b>
Bislama (bi), <b>0209</b>	Laothian (lo), <b>1215</b>	Thai (th), <b>2008</b>
Bengali (bn), <b>0214</b>	Lithuanian (lt), <b>1220</b>	Tigrinya (ti), <b>2009</b>
Tibetan (bo), <b>0215</b>	Latvian (lv), <b>1222</b>	Turkmen (tk), <b>2011</b>
Breton (br), <b>0218</b>	Malagasy (mg), <b>1307</b>	Tagalog (tl), <b>2012</b>
Catalan (ca), <b>0301</b>	Maori (mi), <b>1309</b>	Setswana (tn), <b>2014</b>
Corsican (co), <b>0315</b>	Macedonian (mk), <b>1311</b>	Tonga (to), <b>2015</b>
Czech (cs), <b>0319</b>	Malayalam (ml), <b>1312</b>	Turkish (tr), <b>2018</b>
Welsh (cy), <b>0325</b>	Mongolian (mn), <b>1314</b>	Tsonga (ts), <b>2019</b>
Danish (da), <b>0401</b>	Moldavian (mo), <b>1315</b>	Tatar (tt), <b>2020</b>
Bhutani (dz), <b>0426</b>	Marathi (mr), <b>1318</b>	Twi (tw), <b>2023</b>
Esperanto (eo), <b>0515</b>	Malay (ms), <b>1319</b>	Ukrainian (uk), <b>2111</b>
Estonian (et), <b>0520</b>	Maltese (mt), <b>1320</b>	Urdu (ur), <b>2118</b>
Basque (eu), <b>0521</b>	Burmese (my), <b>1325</b>	Uzbek (uz), <b>2126</b>
Persian (fa), <b>0601</b>	Nauru (na), <b>1401</b>	Vietnamese (vi), <b>2209</b>
Finnish (fi), <b>0609</b>	Nepali (ne), <b>1405</b>	Volapük (vo), <b>2215</b>
Fiji (fj), <b>0610</b>	Norwegian (no), <b>1415</b>	Wolof (wo), <b>2315</b>
Faroese (fo), <b>0615</b>	Occitan (oc), <b>1503</b>	Xhosa (xh), <b>2408</b>
Frisian (fy), <b>0625</b>	Oromo (om), <b>1513</b>	Yoruba (yo), <b>2515</b>
Irish (ga), <b>0701</b>	Oriya (or), <b>1518</b>	Zulu (zu), <b>2621</b>
Scots-Gaelic (gd), <b>0704</b>	Panjabi (pa), <b>1601</b>	
Galician (gl), <b>0712</b>	Polish (pl), <b>1612</b>	



## Additional Information

### Copyright and trademark notice

- This product incorporates copyright protection technology that is protected by method claims of certain U.S. patents and other intellectual property rights owned by Macrovision Corporation and other rights owners. Use of this copyright protection technology must be authorized by Macrovision Corporation, and is intended for home and other limited viewing uses only unless otherwise authorized by Macrovision Corporation. Reverse engineering or disassembly is prohibited.

#### DVD video



**DVD** is a trademark of DVD Format/Logo Licensing Corporation.

#### WMA



Windows Media and the Windows logo are trademarks or registered trademarks of Microsoft Corporation in the United States and/or other countries.

- This product includes technology owned by Microsoft Corporation and cannot be used or distributed without a license from Microsoft Licensing, Inc.

#### MP3

Supply of this product only conveys a license for private, non-commercial use and does not convey a license nor imply any right to use this product in any commercial (i.e. revenue-generating) real time broadcasting (terrestrial, satellite, cable and/or any other media), broadcasting/streaming via internet, intranets and/or other networks or in other electronic content distribution systems, such as pay-audio or audio-on-demand applications. An independent license for such use is required. For details, please visit <http://www.mp3licensing.com>.

#### iTunes

iTunes is a trademark of Apple Inc., registered in the U.S. and other countries.

#### iPod



iPod is a trademark of Apple Inc., registered in the U.S. and other countries.

#### iPhone



iPhone is a trademark of Apple Inc.

## Additional Information

### Dolby Pro Logic II



Manufactured under license from Dolby Laboratories. "Dolby", "Pro Logic", and the double-D symbol are trademarks of Dolby Laboratories.

### DTS Digital Out



Manufactured under license under U.S. Patent #: 5,451,942 & other U.S. and worldwide patents issued & pending. DTS and DTS Digital Out are registered trademarks and the DTS logos and Symbol are trademarks of DTS, Inc. © 1996-2007 DTS, Inc. All Rights Reserved.

### DivX



DivX, DivX Certified, and associated logos are trademarks of DivX, Inc. and are used under license. ▣

## Additional Information

### Terms

#### AAC

AAC is short for Advanced Audio Coding and refers to an audio compression technology standard used with MPEG 2 and MPEG 4.

#### Aspect ratio

This is the width-to-height ratio of a TV screen. A regular display has an aspect ratio of 4:3. Wide screen displays have an aspect ratio of 16:9, providing a bigger picture for exceptional presence and atmosphere.

#### Bit rate

This expresses data volume per second, or bps (bits per second) units. The higher the rate, the more information is available to reproduce the sound. Using the same encoding method (such as MP3), the higher the rate, the better the sound.

#### Chapter

DVD titles are in turn divided into chapters which are numbered in the same way as the chapters of a book. With DVD video discs featuring chapters, you can quickly find a desired scene with chapter search.

#### DivX

DivX is a popular media technology created by DivX, Inc. DivX media files contain highly compressed video with high visual quality that maintains a relatively small file size. DivX files can also include advanced media features like menus, subtitles, and alternate audio tracks. Many DivX media files are available for download online, and you can create your own using your personal content and easy-to-use tools from DivX.com.

#### DivX Certified

DivX Certified products are officially tested by the creators of DivX and guaranteed to play all versions of DivX video, including DivX 6.

#### Dolby Digital

Dolby Digital provides multi-channel audio from up to 5.1 independent channels. This is

the same as the Dolby Digital surround sound system used in theaters.

#### Dolby Pro Logic II

Dolby Pro Logic II can create five full-bandwidth output channels from two-channel sources. This new technology enables a discrete 5-channel playback with 2 front channels, 1 center channel, and 2 rear channels. A music mode is also available for 2-channel sources in addition to the movie mode.

#### DTS

This stands for Digital Theater Systems. DTS is a surround system delivering multi-channel audio from up to 6 independent channels.

#### Dynamic range control

Dolby Digital has a function for compressing the difference between the loudest and softest sounds: Dynamic range control. This control ensures sounds with an increased dynamic range are heard clearly even at low volume levels.

#### EXIF (Exchangeable image file)

A file format developed by Fuji Photo Film for digital still cameras. Digital cameras from various manufacturers use this compressed file format which carries date, time and thumbnail information, as well as the picture data.

#### ID3 tag

This is a method of embedding track-related information in an MP3 file. This embedded information can include the track title, the artist's name, the album title, the music genre, the year of production, comments and other data. The contents can be freely edited using software with ID3 Tag editing functions. Although the tags are restricted as to the number of characters, the information can be viewed when the track is played back.

## Additional Information

### ISO9660 format

This is the international standard for the format logic of CD-ROM folders and files. For the ISO9660 format, there are regulations for the following two levels.

#### Level 1:

The file name is in 8.3 format (the name consists of up to 8 characters, half-byte English capital letters and half-byte numerals and the “\_” sign, with a file-extension of three characters).

#### Level 2:

The file name can have up to 31 characters (including the separation mark “.” and a file extension). Each folder contains less than 8 hierarchies.

### Extended formats

Joliet:

File names can have up to 64 characters.

Romeo:

File names can have up to 128 characters.

### JPEG

This stands for Joint Photographic Experts Group, and is an international still image compression standard.

### Linear PCM (LPCM)/Pulse code modulation

This stands for linear pulse code modulation, which is the signal recording system used for music CDs and DVDs. Generally, DVDs are recorded with higher sampling frequency and bit rate than CDs. Therefore, DVDs can provide higher sound quality.

### m3u

Playlists created using the “WINAMP” software have a playlist file extension (.m3u).

### MP3

MP3 is short for MPEG Audio Layer 3. It is an audio compression standard set by a working group (MPEG) of the ISO (International Standards Organization). MP3 is able to compress audio data to about 1/10th the level of a conventional disc.

### MPEG

This stands for Moving Pictures Experts Group, and is an international video image compression standard. Some DVDs feature digital audio compressed and recorded using this system.

### MS ADPCM

This stands for Microsoft adaptive differential pulse code modulation, which is the signal recording system used for the multimedia software of Microsoft Corporation.

### Multi-angle

With regular TV programs, although multiple cameras are used to simultaneously shoot scenes, only images from one camera at a time are transmitted to your TV. Some DVDs feature scenes shot from multiple angles, letting you choose your viewing angle as desired.

### Multi-audio (Multilingual dialog)

Some DVDs feature dialog recorded in multiple languages. Dialog in up to 8 languages can be recorded on a single disc, letting you choose as desired.

### Multi-session

Multi-session is a recording method that allows additional data to be recorded later. When recording data on a CD-ROM, CD-R or CD-RW, etc., all data from beginning to end is treated as a single unit or session. Multi-session is a method of recording more than 2 sessions on one disc.

### Multi-subtitle

Subtitles in up to 32 languages can be recorded on a single DVD, letting you choose as desired.

### Number of quantization bits

The number of quantization bits is one factor in the overall sound quality; the higher the “bit-depth”, the better the sound quality. However, increasing the bit-depth also increases the amount of data and therefore storage space required.

## Additional Information

### **Packet write**

This is a general term for a method of writing on CD-R, etc., at the time required for a file, just as is done with files on floppy or hard discs.

### **Parental lock**

Some DVD video discs with violent or adult-oriented scenes feature parental lock which prevents children from viewing such scenes. With this kind of disc, if you set the unit's parental lock level, playback of scenes inappropriate for children will be disabled, or these scenes will be skipped.

### **Playback control (PBC)**

This is a playback control signal recorded on Video CDs (Version 2.0). Using menu displays provided by Video CDs with PBC lets you enjoy playback of simple interactive software and software with search functions. You can also enjoy viewing high- and standard-resolution still images.

### **Region number**

DVD players and DVD discs feature region numbers indicating the area in which they were purchased. Playback of a DVD is not possible unless it features the same region number as the DVD player.

### **Title**

DVD video discs have high data capacity, enabling recording of multiple movies on a single disc. If, for example, one disc contains three separate movies, they are divided into title 1, title 2 and title 3. This lets you enjoy the convenience of title search and other functions.

### **VBR**

VBR is short for variable bit rate. Generally speaking CBR (constant bit rate) is more widely used. But by flexibly adjusting the bit rate according to the needs of audio compression, it is possible to achieve compression-priority sound quality.

### **WMA**

WMA is short for Windows Media™ Audio and refers to an audio compression technology that is developed by Microsoft Corporation. WMA data can be encoded by using Windows Media Player version 7 or later.

Windows Media and the Windows logo are trademarks or registered trademarks of Microsoft Corporation in the United States and/or other countries. ■

# Additional Information

## Specifications

### General

Power source .....	14.4 V DC (12.0 V to 14.4 V allowable)
Grounding system .....	Negative type
Max. current consumption .....	10.0 A
Dimensions (W × H × D): DIN	
Chassis .....	178 mm × 100 mm × 165 mm
Nose .....	171 mm × 97 mm × 8 mm
Weight .....	1.7 kg

### Display

Screen size/aspect ratio .....	5.8 inch wide/16:9 (effective display area: 128.1 × 71 mm)
Pixels .....	336 960 (1 440 × 234)
Display method .....	TFT active matrix, transmissive type
Color system .....	NTSC/PAL/PAL-M/SECAM compatible
Durable temperature range (power off) .....	-20 °C to +80 °C

### Audio

Maximum power output .....	50 W × 4 50 W × 2/4 Ω + 70 W × 1/2 Ω (for subwoofer)
Continuous power output .....	22 W × 4 (1 kHz, 5% THD, 4 Ω load, both channels driven)
Load impedance .....	4 Ω to 8 Ω × 4 4 Ω to 8 Ω × 2 + 2 Ω × 1
Preout max output level .....	4.0 V
Equalizer (3-Band Parametric Equalizer): Low	
Frequency .....	40/80/100/160 Hz
Q Factor .....	0.35/0.59/0.95/1.15 (+6 dB when boosted)
Gain .....	±12 dB
Mid	
Frequency .....	200/500/1k/2k Hz
Q Factor .....	0.35/0.59/0.95/1.15 (+6 dB when boosted)
Gain .....	±12 dB
High	
Frequency .....	3.15k/8k/10k/12.5k Hz
Q Factor .....	0.35/0.59/0.95/1.15 (+6 dB when boosted)
Gain .....	±12 dB

### HPF:

Frequency .....	50/63/80/100/125 Hz
Slope .....	-12 dB/oct

### Subwoofer (mono):

Frequency .....	50/63/80/100/125 Hz
Slope .....	-18 dB/oct
Gain .....	+6 dB to -24 dB
Phase .....	Normal/Reverse

### Bass boost:

Gain .....	+12 dB to 0 dB
------------	----------------

### DVD Player

System .....	DVD video, DVD-VR, Video CD, CD, WMA, MP3, AAC, DivX, JPEG system
Usable discs .....	DVD video, Video CD, CD, CD-R/RW, DVD-R/RW/RDL
Region number:	
for Middle East Asian and South African models .....	2
for Southeast Asian models .....	3
for South American and Oceanian models .....	4
Frequency response .....	5 Hz to 44 000 Hz (with DVD, at sampling frequency 96 kHz)
Signal-to-noise ratio .....	96 dB (1 kHz) (IEC-A network) (RCA level)
Output level:	
Video .....	1.0 Vp-p/75 Ω (±0.2 V)
Number of channels .....	2 (stereo)
MP3 decoding format .....	MPEG-1 & 2 Audio Layer 3
WMA decoding format .....	Ver. 7, 7.1, 8, 9, 10, 11 (2ch audio) (Windows Media Player)
AAC decoding format .....	MPEG-4 AAC (iTunes encoded only) (.m4a) (Ver. 8.0 and earlier)
DivX decoding format .....	Home Theater Ver. 3, 4, 5, 2, 6 (.avi, .divx)

### USB

USB standard specification .....	USB 1.1, USB 2.0 full speed
Maximum current supply .....	500 mA
USB Class .....	MSC (Mass Storage Class)
File system .....	FAT16, FAT32
MP3 decoding format .....	MPEG-1 & 2 Audio Layer 3
WMA decoding format .....	Ver. 7, 7.1, 8, 9, 10, 11 (2ch audio) (Windows Media Player)

## Additional Information

AAC decoding format ..... MPEG-4 AAC (iTunes encoded only) (.m4a)  
(Ver. 8.0 and earlier)

### FM tuner

Frequency range ..... 87.5 MHz to 108.0 MHz  
Usable sensitivity ..... 9 dBf (0.7  $\mu$ V/75  $\Omega$ , mono, S/N: 30 dB)  
Signal-to-noise ratio ..... 72 dB (IEC-A network)

### AM tuner

Frequency range ..... 531 kHz to 1 602 kHz (9 kHz)  
530 kHz to 1 640 kHz (10 kHz)  
Usable sensitivity ..... 25  $\mu$ V (S/N: 20 dB)  
Signal-to-noise ratio ..... 62 dB (IEC-A network)

### Infrared remote control

Wavelength ..... 945 nm  
Output ..... typ; 10 mw/sr per Infrared LED



### Note

Specifications and the design are subject to modifications without notice due to improvements. ■

- A**
  - Angle icon ..... 25, 50
  - Aspect ratio ..... 50, 104
  - Audio language ..... 24, 37, 49
- B**
  - Bookmark ..... 23
  - Brightness ..... 58
- C**
  - Chapter ..... 104
  - Code number ..... 51
  - Color ..... 58
  - Contrast ..... 58
- D**
  - DivX ..... 17, 103, 104
  - DivX Certified ..... 104
  - Dolby Digital ..... 8, 104
  - Dolby Pro Logic II ..... 103, 104
  - DTS ..... 8, 104
  - Dynamic range control ..... 104
- E**
  - EXIF ..... 104
- H**
  - Hue ..... 58
- J**
  - JPEG ..... 105
- L**
  - Language code chart ..... 101
  - Linear PCM (LPCM) ..... 105
- M**
  - Menu language ..... 50
  - MPEG ..... 105
  - Multi-angle ..... 25, 105
  - Multi-audio ..... 24, 37, 105
  - Multi-subtitle ..... 25, 37, 105
- P**
  - Parental lock ..... 51, 106
  - PBC (playback control) ..... 27
  - Playback control (PBC) ..... 106
- R**
  - Region number ..... 7, 106
- S**
  - Subtitle language ..... 25, 37, 49
- T**
  - Title ..... 106
  - TV aspect ..... 50
- V**
  - Video CD ..... 94
- W**
  - Wide screen mode ..... 57

Visit us on the World Wide Web at

<http://pioneer.jp/group/index-e.html>

**<Middle East & Africa>**

*Pioneer Gulf.FZE*

<http://www.pioneer-uae.com>

**<Oceania>**

*Pioneer Electronics Australia. Pty.Ltd*

<http://www.pioneeraus.com.au>

**<Asia>**

*Pioneer Electronics Asiacentre.Pte*

<http://www.pioneer.com.sg>

*Pioneer (HK) Ltd.*

<http://www.pioneerhongkong.com.hk>

*Pioneer High Fidelity Taiwan Co., Ltd.*

<http://www.pioneer-twn.com.tw>

**<Latin>**

*Pioneer International Latin America S.A.*

<http://www.pioneer-latin.com>

**PIONEER CORPORATION**

4-1, MEGURO 1-CHOME, MEGURO-KU  
TOKYO 153-8654, JAPAN

**PIONEER ELECTRONICS (USA) INC.**

P.O. Box 1540, Long Beach, California 90801-1540, U.S.A.  
TEL: (800) 421-1404

**PIONEER EUROPE NV**

Haven 1087, Keetberglaan 1, B-9120 Melsele, Belgium/Belgique  
TEL: (0) 3/570.05.11

**PIONEER ELECTRONICS ASIACENTRE PTE. LTD.**

253 Alexandra Road, #04-01, Singapore 159936  
TEL: 65-6472-7555

**PIONEER ELECTRONICS AUSTRALIA PTY. LTD.**

178-184 Boundary Road, Braeside, Victoria 3195, Australia  
TEL: (03) 9586-6300

**PIONEER ELECTRONICS OF CANADA, INC.**

300 Allstate Parkway, Markham, Ontario L3R 0P2, Canada  
TEL: 1-877-283-5901  
TEL: 905-479-4411

**PIONEER ELECTRONICS DE MEXICO, S.A. de C.V.**

Bvd.Manuel Avila Camacho 138 10 piso  
Col.Lomas de Chapultepec, Mexico, D.F. 11000  
TEL: 55-9178-4270

**先鋒股份有限公司**

總公司：台北市中山北路二段44號13樓  
電話：(02) 2521-3588

**先鋒電子（香港）有限公司**

香港九龍尖沙嘴海港城世界商業中心  
9樓901-6室  
電話：(0852) 2848-6488

Published by Pioneer Corporation.

Copyright © 2008 by Pioneer Corporation.  
All rights reserved.

Printed in Thailand

<CRB2868-A/N> RC, RD, RI

<KOKZX> <08J00000>