

Operation Manual

Multi-CD control DSP High power CD/MP3/WMA/
AAC player with Bluetooth Wireless Technology and
FM/AM tuner

DEH-P9850BT



Thank you for buying this Pioneer product.

Please read through these operating instructions so you will know how to operate your model properly. *After you have finished reading the instructions, keep this manual in a safe place for future reference.*

01 Before You Start

- About this unit **6**
 - Operating environment **6**
- About this manual **6**
- Features **6**
- About WMA **7**
- About AAC **7**
- About Bluetooth **7**
- Resetting the microprocessor **8**
- Clearing all memory **8**
- Protecting your unit from theft **8**
 - Removing the front panel **9**
 - Attaching the front panel **9**
- About the demo mode **9**
 - Reverse mode **9**
 - Feature demo mode **10**
- Use and care of the remote control **10**
 - Installing the battery **10**
 - Using the remote control **10**
 - FUNCTION button and AUDIO button **10**

02 What's What

- Head unit **12**
- Remote control **12**

03 Basic Operations

- Turning the unit on **14**
- Selecting a source **14**
- Loading a disc **14**
- Adjusting the volume **15**
- Turning the unit off **15**

04 Tuner

- Listening to the radio **16**
- Introduction of advanced tuner operation **17**
- Storing and recalling broadcast frequencies **17**
- Storing the strongest broadcast frequencies **17**

- Selecting stations from the preset channel list **18**

- Tuning in strong signals **18**

05 Built-in CD Player

- Playing a CD **19**
- Selecting a track directly **19**
- Introduction of advanced built-in CD player operation **20**
- Repeating play **20**
- Playing tracks in random order **20**
- Scanning tracks of a CD **21**
- Pausing CD playback **21**
- Selecting the search method **21**
- Searching every 10 tracks in the current disc **21**
- Using disc title functions **22**
 - Entering disc titles **22**
 - Displaying disc titles **23**
- Using CD TEXT functions **23**
 - Displaying text information on CD TEXT discs **23**
 - Scrolling text information in the display **23**
 - Selecting tracks from the track title list **23**

06 MP3/WMA/AAC/WAV Player

- Playing MP3/WMA/AAC/WAV files **24**
- Selecting a track directly in the current folder **25**
- Introduction of advanced built-in CD player (MP3/WMA/AAC/WAV) operation **26**
- Repeating play **26**
- Playing tracks in random order **26**
- Scanning folders and tracks **27**
- Pausing MP3/WMA/AAC/WAV playback **27**
- Selecting the search method **27**
- Searching every 10 tracks in the current folder **27**

- Displaying text information on MP3/WMA/
AAC/WAV disc **28**
 - When playing back an MP3/WMA/AAC
disc **28**
 - When playing back a WAV disc **28**
- Scrolling text information in the display **28**
- Selecting tracks from the file name list **29**
- Displaying jacket arts on CD-ROM discs **29**
 - Reading jacket arts **29**
 - Selecting folders with jacket arts **30**

07 Bluetooth Telephone

- Hands-free phoning with cellular phones
featuring Bluetooth wireless
technology **31**
- About the telephone source **32**
 - Standby mode **32**
- Setting up for hands-free phoning **32**
- Basic operation of hands-free phoning **33**
 - Making a phone call **33**
 - Taking a phone call **34**
- Introduction of advanced hands-free phoning
operation **35**
- Connecting a cellular phone **35**
 - Searching for available cellular
phones **36**
 - Using a cellular phone to initiate a
connection **36**
- Disconnecting a cellular phone **37**
- Registering connected cellular phone **37**
- Deleting a registered phone **37**
- Connecting to a registered cellular
phone **38**
 - Connecting to a registered phone
manually **38**
 - Connecting to a registered phone
automatically **38**
- Using the Phone Book **39**
 - Transferring entries to the Phone
Book **39**

- Changing the Phone Book display
order **40**
- Calling a number in the Phone
Book **40**
- Assign genres to phone numbers **40**
- Editing the name of a Phone Book
entry **41**
- Editing phone numbers **42**
- Selecting the icon of a Phone Book
entry **42**
- Clearing a Phone Book entry **43**
- Using preset numbers **43**
- Clearing memory **43**
- Using the Call History **44**
 - Displaying the Call History **44**
 - Calling a number from the Call
History **45**
 - Assigning preset numbers **45**
- Making a call by entering phone number **45**
- Echo canceling and noise reduction **46**
- Changing the ring tone **46**
- Setting the automatic rejecting **47**
- Setting the automatic answering **47**
- Selecting the icon for user phone **47**
- Displaying BD (Bluetooth Device)
address **47**
 - Displaying BD address of your cellular
phone **48**
 - Displaying BD address of this unit **48**
- Displaying system version for repair **48**

08 Bluetooth Audio

- Listening to songs on BT Audio (Bluetooth
audio player) **49**
- Setting up for Bluetooth audio player **49**
- Connecting a Bluetooth audio player **50**
- Function operation **51**
- Playing songs on Bluetooth audio player **51**
- Pausing a song **51**
- Stopping playback **51**
- Disconnecting a Bluetooth audio player **52**

Displaying BD address of this unit **52**
Displaying system version for repair **52**

09 Multi-CD Player

Playing a CD **53**
Selecting a track directly **53**
50-disc multi-CD player **54**
Introduction of advanced multi-CD player operation **54**
Repeating play **55**
Playing tracks in random order **55**
Scanning CDs and tracks **55**
Pausing CD playback **56**
Using ITS playlists **56**

- Creating a playlist with ITS programming **56**
- Playback from your ITS playlist **56**
- Erasing a track from your ITS playlist **57**
- Erasing a CD from your ITS playlist **57**

Using disc title functions **57**

- Entering disc titles **57**
- Displaying disc titles **58**
- Selecting discs from the disc title list **58**

Using CD TEXT functions **58**

- Displaying text information on CD TEXT discs **59**
- Scrolling text information in the display **59**
- Selecting tracks from the track title list **59**

10 Playing songs on iPod

Listening to songs on your iPod **60**
Browsing for a song **60**

- Searching for a song **61**
- Selecting a playlist **61**

Displaying text information on iPod **61**
Introduction of advanced iPod adapter operation **62**

Repeating play **62**
Playing songs in a random order (shuffle) **62**
Pausing a song **63**

11 TV tuner

Watching the television **64**
Introduction of advanced TV tuner operation **65**
Storing and recalling broadcast stations **65**
Storing the strongest broadcast stations sequentially **65**
Selecting stations from the preset channel list **66**

12 DVD Player

Playing a disc **67**
Selecting a disc **67**
Selecting a folder **67**
Introduction of advanced DVD player operation **68**
Repeating play **68**
Pausing disc playback **69**
Playing tracks in random order **69**
Scanning tracks of a CD/MP3/WMA **69**
Using ITS playlist and disc title functions **69**
Using disc title functions **69**

- Entering disc titles **70**

13 Audio Adjustments

Adjusting the audio easily **71**
Adjusting the audio finely **71**
Extra functions **71**
Introduction of audio adjustments **71**
Using the position selector **72**
Using balance adjustment **72**
Using the time alignment **73**

- Adjusting the time alignment **73**

Using subwoofer output **74**

- Adjusting subwoofer settings **74**

- Adjusting low pass filter attenuation slope **74**
 - Using the high pass filter **75**
 - Muting the speaker units (filters) **75**
 - Setting the high pass filter for front speakers **75**
 - Setting the high pass filter for rear speakers **76**
 - Using the auto-equalizer **76**
 - Using the equalizer **76**
 - Recalling equalizer curves **76**
 - Adjusting equalizer curves **77**
 - Adjusting 16-band graphic equalizer **77**
 - Using BBE sound **78**
 - Using compression and BMX **78**
 - Adjusting loudness **79**
 - Adjusting source levels **79**
 - Using auditory user interface **79**
 - Auto TA and EQ (auto-time alignment and auto-equalizing) **80**
 - Before operating the auto TA and EQ function **80**
 - Carrying out auto TA and EQ **81**
- 14 Initial Settings**
- Adjusting initial settings **83**
 - Selecting the display language **83**
 - Setting the date **83**
 - Setting the clock **84**
 - Setting the FM tuning step **84**
 - Setting the AM tuning step **84**
 - Switching the warning tone **85**
 - Switching the face auto open **85**
 - Switching the auxiliary setting **85**
 - Switching the dimmer setting **85**
 - Adjusting the brightness **85**
 - Correcting distorted sound **86**
 - Switching the sound muting/attenuation **86**
 - Switching the feature demo **86**
 - Switching the reverse mode **87**
 - Switching the Ever Scroll **87**
 - Calibrating the RPMs **87**
 - Activating the BT Audio source **87**
 - Entering PIN code for Bluetooth wireless connection **88**
 - Resetting the Bluetooth wireless technology module **88**
- 15 Other Functions**
- Turning the clock display on or off **89**
 - Using the AUX source **89**
 - About AUX1 and AUX2 **89**
 - Selecting AUX as the source **89**
 - Setting the AUX title **89**
 - Using different entertainment displays **90**
 - Setting the entertainment display **90**
 - Setting the background display **91**
 - Rewriting the entertainment displays and the icons for telephone functions **92**
- Additional Information**
- Understanding built-in CD player error messages **93**
 - Understanding auto TA and EQ error messages **93**
 - Understanding error message on rewriting the entertainment displays **94**
 - CD player and care **94**
 - CD-R/CD-RW discs **94**
 - Dual Discs **95**
 - MP3, WMA, AAC and WAV files **95**
 - MP3 additional information **96**
 - WMA additional information **96**
 - AAC additional information **96**
 - WAV additional information **97**
 - About folders and MP3/WMA/AAC/WAV files **97**
 - Terms **99**
 - Specifications **101**

About this unit

CAUTION

- Do not allow this unit to come into contact with liquids. Electrical shock could result. Also, this unit damage, smoke, and overheat could result from contact with liquids.
- Keep this manual handy as a reference for operating procedures and precautions.
- Always keep the volume low enough so that you can hear sounds from outside the vehicle.
- Protect this unit from moisture.
- If the battery is disconnected or discharged, the preset memory will be erased and must be reprogrammed.
- If this unit does not operate properly, contact your dealer or nearest authorized Pioneer Service Station.

Operating environment

This unit should be used within the temperature ranges shown below.

Operating temperature range: -10°C to $+60^{\circ}\text{C}$ (14°F to 140°F)

EN300328 ETC test temperature: -20°C and $+55^{\circ}\text{C}$ (-4°F and 131°F) 

About this manual

This unit features a number of sophisticated functions ensuring superior reception and operation. All the functions have been designed for the easiest possible use, but many are not self-explanatory. This operation manual will help you benefit fully from this unit's potential and to maximize your listening enjoyment. We recommend that you familiarize yourself with the functions and their operation by reading through the manual before you begin using this unit. It is especially important that

you read and observe **WARNINGs** and **CAUTIONs** in this manual. 

Features

CD playback

Music CD/CD-R/CD-RW playback is possible.

MP3 file playback

You can play back MP3 files recorded on CD-ROM/CD-R/CD-RW (ISO9660 Level 1/Level 2 standard recordings).

- Supply of this product only conveys a license for private, non-commercial use and does not convey a license nor imply any right to use this product in any commercial (i.e. revenue-generating) real time broadcasting (terrestrial, satellite, cable and/or any other media), broadcasting/streaming via internet, intranets and/or other networks or in other electronic content distribution systems, such as pay-audio or audio-on-demand applications. An independent license for such use is required. For details, please visit <http://www.mp3licensing.com>.

WMA file playback

You can play back WMA files recorded on CD-ROM/CD-R/CD-RW (ISO9660 Level 1/Level 2 standard recordings).

AAC file playback

You can play back AAC files recorded on CD-ROM/CD-R/CD-RW (ISO9660 Level 1/Level 2 standard recordings).

WAV file playback

You can play back WAV files recorded on CD-ROM/CD-R/CD-RW (Linear PCM (LPCM)/MS ADPCM recordings).

Before You Start

Hands-free phoning

This unit realizes effortless hands-free phoning with Bluetooth wireless technology.

Bluetooth audio player compatibility

When you use this unit with a Bluetooth audio player featuring Bluetooth wireless technology, you can control the Bluetooth audio player.

iPod® compatibility

When you use this unit with a Pioneer iPod adapter (CD-IB100), you can control an iPod with Dock Connector.

- iPod is a trademark of Apple Computer, Inc., registered in the U.S. and other countries. 

About WMA



The Windows Media™ logo printed on the box indicates that this unit can play back WMA data.

WMA is short for Windows Media Audio and refers to an audio compression technology that is developed by Microsoft Corporation. WMA data can be encoded by using Windows Media Player version 7 or later.

Windows Media and the Windows logo are trademarks or registered trademarks of Microsoft Corporation in the United States and/or other countries.

Notes

- This unit may not operate correctly depending on the application used to encode WMA files.

- Depending on the version of Windows Media Player used to encode WMA files, album names and other text information may not be correctly displayed.
- There may be a slight delay when starting playback of WMA files encoded with image data. 

About AAC

AAC is short for Advanced Audio Coding and refers to an audio compression technology standard used with MPEG 2 and MPEG 4. Several applications can be used to encode AAC files, but file formats and extensions differ depending on the application which is used to encode.

This unit plays back AAC files encoded by iTunes® version 4.8 and earlier.

iTunes is a trademark of Apple Computer, Inc., registered in the U.S. and other countries. 

About Bluetooth



Bluetooth is a short-range wireless radio connectivity technology that is developed as a cable replacement for mobile phones, handheld PCs and other devices. Bluetooth operates in 2.4 GHz frequency range and transmits voice and data at speeds up to 1 megabit per second. Bluetooth was launched by a special interest group (SIG) that comprises of Ericsson Inc., Intel Corp., Nokia Corp., Toshiba and IBM in 1998, and it is currently developed by nearly 2 000 companies worldwide.

Before You Start

- The Bluetooth word mark and logos are owned by the Bluetooth SIG, Inc. and any use of such marks by Pioneer Corporation is under license. Other trademarks and trade names are those of their respective owners. ■

Resetting the microprocessor

The microprocessor must be reset under the following conditions:

- Prior to using this unit for the first time after installation
- If the unit fails to operate properly
- When strange or incorrect messages appear on the display

- **Press RESET with a pen tip or other pointed instrument.**

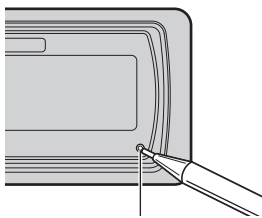

RESET button



Clearing all memory

To protect personal and private information, data about the phone stored in this unit can be deleted.

- 1 Press SOURCE and hold until the unit turns off.**

- 2 Press MULTI-CONTROL and hold until Language select appears in the display.**

- 3 Turn MULTI-CONTROL to select Phone reset.**

Phone reset appears in the display.

- 4 Push MULTI-CONTROL right to show a confirmation display.**

Clear memory YES is displayed. Clearing memory is now on standby.

- If you do not want to reset phone memory, press **BAND**.

- 5 Press MULTI-CONTROL to clear the memory.**

All data in the telephone source, including Phone Book entries, number presets and the Call History is cleared. ■

Protecting your unit from theft

The front panel can be detached from the head unit and stored in the provided protective case to prevent theft.

- If the front panel is not detached from the head unit within five seconds of turning off the ignition, a warning tone will sound and the front panel will open.
- You can turn off the warning tone. See *Switching the warning tone* on page 85.
- You can turn off the face auto open. See *Switching the face auto open* on page 85.



Important

- Never use force or grip the display and the buttons too tightly when removing or attaching.
- Avoid subjecting the front panel to excessive shocks.
- Keep the front panel out of direct sunlight and high temperatures.

Before You Start

- A few seconds after turning the ignition switch to on or off, the front panel automatically moves. When this happens, your fingers may become jammed in the panel, so keep your hands away from it.

Removing the front panel

- 1 Press and hold EJECT to open the front panel.

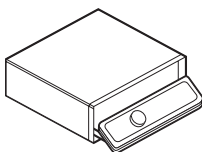

- 2 Slide and remove the front panel toward you.

Take care not to grip it too tightly or to drop the front panel and protect it from contact with water or other fluids to prevent permanent damage.

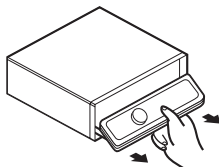

- 3 Put the front panel into provided protective case for safe keeping.

Attaching the front panel

- 1 Make sure the inner cover is closed.

- 2 Replace the front panel by clipping it into place.

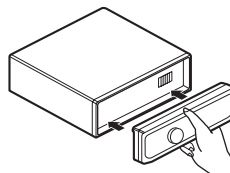

About the demo mode

This unit features two demonstration modes. One is the reverse mode, the other is the feature demo mode.

Important

The red lead (ACC) of this unit should be connected to a terminal coupled with ignition switch on/off operations. If this is not done, the vehicle battery may be drained.

Reverse mode

If you do not perform an operation within about 30 seconds, screen indications start to reverse, and then continue reversing every 10 seconds. Pressing **BAND** when power to this unit is turned off while the ignition switch is set to ACC or ON cancels the reverse mode. Press **BAND** again to start the reverse mode.

Feature demo mode

The feature demo automatically starts when power to this unit is turned off while the ignition switch is set to ACC or ON. Pressing **DISPLAY** during feature demo operation cancels the feature demo mode. Press **DISPLAY** again to start the feature demo mode. Remember that if the feature demo continues operating when the car engine is turned off, it may drain battery power. ▣

Use and care of the remote control

Installing the battery

Slide the tray out on the back of the remote control and insert the battery with the plus (+) and minus (-) poles pointing in the proper direction.

- When using for the first time, pull out the film protruding from the tray.

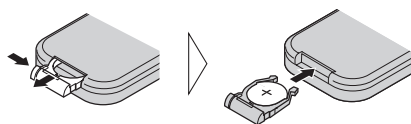

⚠ WARNING

Keep the battery out of the reach of children. Should the battery be swallowed, immediately consult a doctor.

⚠ CAUTION

- Use only one **CR2025 (3 V)** lithium battery.
- Remove the battery if the remote control is not used for a month or longer.
- Do not recharge, disassemble, heat or dispose of the battery in fire.
- Do not handle the battery with metallic tools.

- Do not store the battery with metallic materials.
- In the event of battery leakage, wipe the remote control completely clean and install a new battery.
- When disposing of used batteries, please comply with governmental regulations or environmental public institutions' rules that apply in your country/area.

Using the remote control

Point the remote control in the direction of the front panel to operate.

- The remote control may not function properly in direct sunlight.

🔒 Important

- Do not store the remote control in high temperatures or direct sunlight.
- Do not let the remote control fall onto the floor, where it may become jammed under the brake or accelerator pedal.

FUNCTION button and AUDIO button

You can also select the desired mode by **FUNCTION** button and **AUDIO** button on the remote control. But operation of **FUNCTION** button and **AUDIO** button on the remote control differs from the operation of **MULTI-CONTROL** on the head unit. When operating the remote control, switch through the modes as described below to select the mode.

FUNCTION button operation

- **Press FUNCTION to select the desired mode (e.g., built-in CD player).**

Press **FUNCTION** repeatedly to switch between the following modes:

Before You Start

Play mode (repeat play)—**Random mode** (random play)—**Scan mode** (scan play)—**Pause** (pause)—**Search mode** (search method)—**Title Input** (disc title input)—**Jacket art** (jacket art read)



Note

Refer to *Introduction of advanced built-in CD player operation* on page 20.

AUDIO button operation

● Press AUDIO to select the desired mode.

Press **AUDIO** repeatedly to switch between the following modes:

Fader (balance adjustment)—**Position** (position selector)—**TA Mode** (time alignment setting)—**Time Alignment** (time alignment adjusting)—**Loudness** (loudness)—**Powerful** (graphic equalizer adjustment)—**FREQ.** (16-band graphic equalizer adjustment)—**Subwoofer1** (subwoofer on/off)—**Subwoofer2** (subwoofer cut-off frequency)—**Subwoofer3** (subwoofer slope)—**Front HPF** (front high pass filter slope)—**Front HPF FREQ.** (front high pass filter cut-off frequency)—**Rear HPF** (rear high pass filter slope)—**Rear HPF FREQ.** (rear high pass filter cut-off frequency)—**BBE** (BBE)—**COMP/BMX** (Compression and BMX)—**Auto EQ** (auto-equalizer on/off)—**SLA** (source level adjustment)—**AUI sound level** (auditory user interface)



Note

Refer to *Introduction of audio adjustments* on page 71.

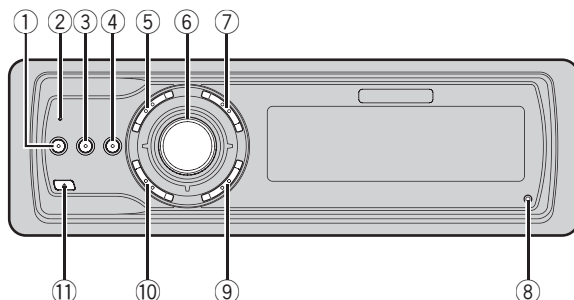

Head unit

① EQ button

Press to select various equalizer curves.

② Connection status indicator

Lights up when your cellular phone is connected via Bluetooth wireless technology.

③ DISPLAY button

Press to select different displays.

④ CLOCK button

Press to change to the clock display.

⑤ PHONE button

Press to select the phone as the source. While operating a phone source, press to end a call, reject an incoming call or cancel making a call.

⑥ MULTI-CONTROL

Move to perform manual seek tuning, fast forward, reverse and track search controls. Also used for controlling functions. Turn to increase or decrease the volume.

⑦ LIST button

Press to display the disc title list, track title list, folder list, file list or preset channel list depending on the source.

⑧ RESET button

Press to reset the microprocessor.

⑨ BAND button

Press to select among three FM bands and one AM band and to cancel the control mode of functions.

⑩ SOURCE button

This unit is turned on by selecting a source. Press to cycle through all the available sources.

⑪ EJECT button

Press to eject a CD from your built-in CD player. Press and hold to open or close the front panel.

Remote control

Operation is the same as when using the buttons on the head unit.

⑫ VOLUME buttons

Press to increase or decrease the volume.

⑬ FUNCTION button

Press to select functions.

What's What

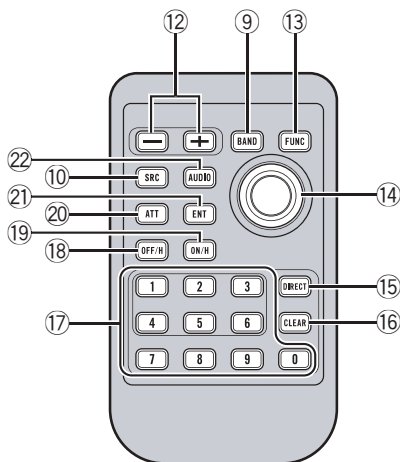

14 Joystick

Move to perform manual seek tuning, fast forward, reverse and track search controls. Also used for controlling functions. Functions are the same as **MULTI-CONTROL** except for volume control.

15 DIRECT button

Press to directly select the desired track.

16 CLEAR button

Press to cancel the input number when **0-9** are used.

17 0-9 buttons

Press to directly select the desired track, preset tuning or disc. Buttons **1-6** can operate the preset tuning for the tuner or disc number search for the multi-CD player.

18 OFF HOOK button

Press to start talking on the phone while operating a phone source.

19 ON HOOK button

While operating the phone source, press to end a call or reject an incoming call.

20 ATT button

Press to quickly lower the volume level, by about 90%. Press once more to return to the original volume level.

21 ENTERTAINMENT button

Press to change to the entertainment display.

22 AUDIO button

Press to select various sound quality controls. 

Turning the unit on

- **Press SOURCE to turn the unit on.**

When you select a source, the unit is turned on. 

Selecting a source

You can select a source you want to listen to. To switch to the built-in CD player, load a disc in the unit (refer to page 19).

- **Press SOURCE to select a source.**

Press **SOURCE** repeatedly to switch between the following sources:

Tuner—Television—DVD player/Multi-DVD player—Built-in CD player—Multi-CD player—iPod—External unit 1—External unit 2—AUX1—AUX2—Telephone—BT Audio



Notes

- In the following cases, the sound source will not change:
 - When there is no unit corresponding to the selected source connected to this unit.
 - When there is no disc in the unit.
 - When there is no disc in the DVD player.
 - When there is no magazine in the multi-CD player.
 - When there is no magazine in the multi-DVD player.
 - When the AUX (auxiliary input) is set to off (refer to page 85).
 - When the **BT Audio** source is set to off (refer to *Activating the BT Audio source* on page 87).
- External unit refers to a Pioneer product (such as one available in the future) that, although incompatible as a source, enables control of basic functions by this unit. Two external units can be controlled by this unit. When two external units are connected, the allocation of

them to external unit 1 or external unit 2 is automatically set by this unit.

- When this unit's blue/white lead is connected to the vehicle's auto-antenna relay control terminal, the vehicle's antenna extends when this unit's source is turned on. To retract the antenna, turn the source off. 

Loading a disc

- 1 Press EJECT to open the front panel.**

CD loading slot appears.

- After a CD has been inserted, press **SOURCE** to select the built-in CD player.

- 2 Insert a CD into the CD loading slot.**

Front panel is closed automatically, and playback will start.

- With jacket art function on, jacket arts on CD-ROM disc are automatically read in this unit when the disc is inserted. To cancel reading jacket arts, press **BAND**. For details, refer to *Reading jacket arts* on page 29.

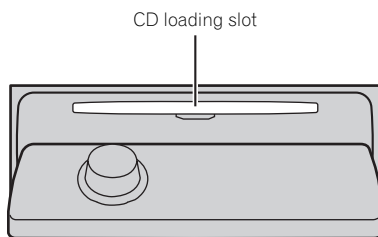

- You can eject a CD by pressing **EJECT**.



Notes

- The built-in CD player plays one standard, 12-cm or 8-cm CD at a time. Do not use an adapter when playing 8-cm CDs.
- Do not insert anything other than a CD into the CD loading slot.

Basic Operations

- There is sometimes a delay between starting up CD playback and the sound being issued. When being read, **Format read** is displayed.
- If you cannot insert a disc completely or if after you insert a disc the disc does not play, check that the label side of the disc is up. Press **EJECT** to eject the disc, and check the disc for damage before inserting it again.
- When the CD loading or ejecting function does not operate properly, you can eject the CD by pressing and holding **EJECT** while opening the front panel.
- If an error message such as **ERROR-11** is displayed, refer to *Understanding built-in CD player error messages* on page 93.

Adjusting the volume

- Use **MULTI-CONTROL** to adjust the sound level.

With the head unit, turn **MULTI-CONTROL** to increase or decrease the volume.

With the remote control, press **VOLUME** to increase or decrease the volume.

Turning the unit off

- Press **SOURCE** and hold until the unit turns off.

Listening to the radio

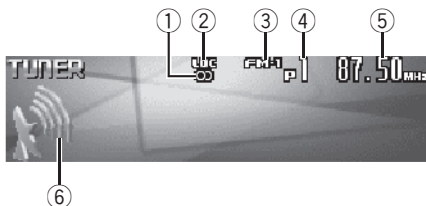

These are the basic steps necessary to operate the radio. More advanced tuner operation is explained starting on the next page.



Important

If you are using this unit in North, Central or South America, reset the AM tuning step (see *Setting the AM tuning step* on page 84).

① Stereo (Ⓞ) indicator

Shows when the selected frequency is being broadcast in stereo.

② LOC indicator

Shows when local seek tuning is on.

③ Band indicator

Shows which band the radio is tuned to, AM or FM.

④ Preset number indicator

Shows which preset has been selected.

⑤ Frequency indicator

Shows the frequency to which the tuner is tuned.

⑥ Signal level indicator

Shows the radio wave strength.

1 Press SOURCE to select the tuner.

Press **SOURCE** until you see **Tuner** displayed.

2 Press BAND to select a band.

Press **BAND** until the desired band (**FM-1**, **FM-2**, **FM-3** for FM or **AM**) is displayed.

3 To perform manual tuning, push MULTI-CONTROL left or right.

The frequencies move up or down step by step.

4 To perform seek tuning, push and hold MULTI-CONTROL left or right for about one second and release.

The tuner will scan the frequencies until a broadcast strong enough for good reception is found.

- You can cancel seek tuning by pushing **MULTI-CONTROL** left or right.
- If you push and hold **MULTI-CONTROL** left or right you can skip stations. Seek tuning starts as soon as you release **MULTI-CONTROL**. 

Tuner

Introduction of advanced tuner operation

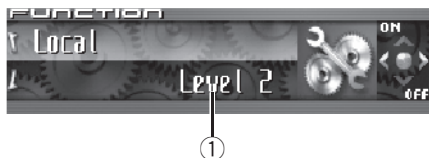

① Function display

Shows the function status.

1 Press **MULTI-CONTROL** to display the main menu.

FUNCTION, **AUDIO** and **ENTERTAINMENT** appear on the display.

2 Use **MULTI-CONTROL** to select **FUNCTION**.

Turn to change the menu option; press to select.

The function name appears on the display.

3 Turn **MULTI-CONTROL** to select the function.

Turn **MULTI-CONTROL** clockwise or counter-clockwise to switch between the functions in the following order:

BSM (best stations memory)—**Local** (local seek tuning)

- To return to the frequency display, press

BAND.

Note

If you do not operate the function within about 30 seconds, the display is automatically returned to the frequency display. 

Storing and recalling broadcast frequencies

You can easily store up to six broadcast frequencies for later recall.

1 When you find a frequency that you want to store in memory press **LIST** to switch to the preset channel list mode.

2 Use **MULTI-CONTROL** to store the selected frequency in memory.

Turn to change the preset number; press and hold to store.

The preset number you have selected will flash and then remain lit. The selected radio station frequency has been stored in memory.

- If you do not operate the list within about 30 seconds, the preset channel list mode is canceled automatically.

Notes

- Up to 18 FM stations, six for each of the three FM bands, and six AM stations can be stored in memory.
- You can also store radio station frequencies assigned to preset tuning numbers by pressing and holding one of the preset tuning buttons **1-6** on the remote control. 

Storing the strongest broadcast frequencies

BSM (best stations memory) lets you automatically store the six strongest broadcast frequencies under preset tuning buttons **1-6**.

Once stored you can tune in to those frequencies with the touch of button.

1 Use **MULTI-CONTROL** to select **BSM** in the function menu.

BSM appears in the display.

2 Press MULTI-CONTROL to turn BSM on.

Searching is displayed. While **Searching** is displayed, the six strongest broadcast frequencies will be stored under preset tuning numbers **1–6** in the order of their signal strength. When finished, the preset channel list appears.

- To cancel the storage process, press **MULTI-CONTROL**.

3 Use MULTI-CONTROL to select the desired station.

Turn to change the station; press to select.

- You can also change the station by pushing **MULTI-CONTROL** up or down.



Note

Storing broadcast frequencies with BSM may replace broadcast frequencies you have saved using buttons **1–6**. 

Selecting stations from the preset channel list

The preset channel list lets you see the list of preset stations and select one of them to receive.

1 Press LIST to switch to the preset channel list mode during the frequency display.

2 Use MULTI-CONTROL to select the desired station.

Turn to change the station; press to select.

- You can also change the station by pushing **MULTI-CONTROL** up or down.
- If you do not operate the list within about 30 seconds, the preset channel list mode is canceled automatically.



Notes

- You can also recall radio station frequencies assigned to preset tuning numbers by pushing **MULTI-CONTROL** up or down during the frequency display.
- You can also recall radio station frequencies assigned to preset tuning numbers by pressing one of the preset tuning buttons **1–6** on the remote control. 

Tuning in strong signals

Local seek tuning lets you tune in only those radio stations with sufficiently strong signals for good reception.

1 Use MULTI-CONTROL to select Local in the function menu.

Local appears in the display.

2 Press MULTI-CONTROL to turn local seek tuning on.

Local seek sensitivity (e.g., **Level 2**) appears in the display.

- To turn local seek tuning off, press **MULTI-CONTROL** again.

3 Push MULTI-CONTROL left or right to set the sensitivity.

There are four levels of sensitivity for FM and two levels for AM:

FM: **Level 1—Level 2—Level 3—Level 4**

AM: **Level 1—Level 2**

The **Level 4** setting allows reception of only the strongest stations, while lower settings let you receive progressively weaker stations. 

Built-in CD Player

Playing a CD

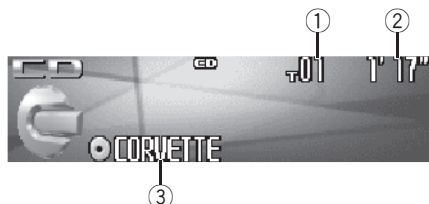

These are the basic steps necessary to play a CD with your built-in CD player. More advanced CD operation is explained starting on the next page.

① Track number indicator

Shows the track number currently playing.

② Play time indicator

Shows the elapsed playing time of the current track.

③ Disc title indicator

Shows the title of the currently playing disc.

- If no title has been entered for the currently playing disc, nothing is displayed.

1 Press SOURCE to select the built-in CD player.

Press **SOURCE** until you see **Compact Disc** displayed.

- If no disc is loaded in the unit, you cannot select **Compact Disc** (built-in CD player). Insert a disc in the unit. (Refer to page 14.)

2 To perform fast forward or reverse, push and hold MULTI-CONTROL left or right.

- If you select **Rough search**, pushing and holding **MULTI-CONTROL** left or right enables you to search every 10 tracks in the current disc. (Refer to *Selecting the search method* on page 21.)

3 To skip back or forward to another track, push MULTI-CONTROL left or right.

Pushing **MULTI-CONTROL** right skips to the start of the next track. Pushing **MULTI-CONTROL** left once skips to the start of the current track. Pushing again will skip to the previous track.



Note

When a CD TEXT disc is inserted, the disc title automatically begins to scroll in the display. When Ever Scroll is set to ON at the initial setting, the disc title scrolls continuously. Refer to *Switching the Ever Scroll* on page 87. ■

Selecting a track directly

When using the remote control, you can select a track directly by entering the desired track number.

1 Press DIRECT.

Track number input display appears.

2 Press 0–9 buttons to enter the desired track number.

- You can cancel the input number by pressing **CLEAR**.

3 Press DIRECT.

The track of entered number will play.



Note

After entering the number input mode, if you do not perform an operation within about eight seconds, the mode is automatically canceled. ■

Introduction of advanced built-in CD player operation



① Function display

Shows the function status.

1 Press MULTI-CONTROL to display the main menu.

FUNCTION, **AUDIO** and **ENTERTAINMENT** appear on the display.

2 Use MULTI-CONTROL to select FUNCTION.

Turn to change the menu option; press to select.

The function name appears on the display.

3 Turn MULTI-CONTROL to select the function.

Turn **MULTI-CONTROL** clockwise or counter-clockwise to switch between the functions in the following order:

Play mode (repeat play)—**Random mode** (random play)—**Scan mode** (scan play)—**Pause** (pause)—**Search mode** (search method)—**Title Input** (disc title input)—**Jacket art** (jacket art read)

- To return to the playback display, press **BAND**.

Notes

- When playing a CD **TEXT** disc, you cannot switch to **Title Input**. The disc title will have already been recorded on a CD **TEXT** disc.
- When playing audio data (CD-DA), it is not effective even if you turn **Jacket art** on. (Refer to page 29.)

- If you do not operate the function within about 30 seconds, the display is automatically returned to the playback display. 

Repeating play

There are two repeat play ranges for the built-in CD player: **Disc repeat** (disc repeat) and **Track repeat** (one-track repeat).

1 Use MULTI-CONTROL to select Play mode in the function menu.

Play mode appears in the display.

2 Press MULTI-CONTROL to select the repeat range.

Press **MULTI-CONTROL** repeatedly until the desired repeat range appears in the display.

- **Disc repeat** – Repeat the current disc
- **Track repeat** – Repeat just the current track

Note

If you perform track search or fast forward/reverse during **Track repeat**, the repeat play range changes to **Disc repeat**. 

Playing tracks in random order

Random play lets you play back tracks on the CD in a random order.

1 Use MULTI-CONTROL to select Random mode in the function menu.

Random mode appears in the display.

2 Press MULTI-CONTROL to turn random play on.

Tracks will play in a random order.

- To turn random play off, press **MULTI-CONTROL** again. 

Built-in CD Player

Scanning tracks of a CD

Scan play lets you hear the first 10 seconds of each track on the CD.

1 Use MULTI-CONTROL to select Scan mode in the function menu.
Scan mode appears in the display.

2 Press MULTI-CONTROL to turn scan play on.
The first 10 seconds of each track is played.

3 When you find the desired track press MULTI-CONTROL to turn scan play off.
The track will continue to play.

- If the display has automatically returned to the playback display, select **Scan mode** again by using **MULTI-CONTROL**.



Note

After scanning of a CD is finished, normal playback of the tracks will begin again. 

Pausing CD playback

Pause lets you temporarily stop playback of the CD.

1 Use MULTI-CONTROL to select Pause in the function menu.
Pause appears in the display.

2 Press MULTI-CONTROL to turn pause on.
Playback of the current track pauses.

- To turn pause off, press **MULTI-CONTROL** again. 

Selecting the search method

You can switch the search method between fast forward/reverse and searching every 10 tracks.

1 Use MULTI-CONTROL to select Search mode in the function menu.
Search mode appears in the display.

2 Press MULTI-CONTROL to select the search method.
Press **MULTI-CONTROL** until the desired search method appears in the display.

- **FF/REV** – Fast forward and reverse
- **Rough search** – Searching every 10 tracks 

Searching every 10 tracks in the current disc

If a disc contains over 10 tracks, you can search every 10 tracks. When a disc contains many tracks, you can roughly search for the track you want to play.

1 Select the search method Rough search.
Refer to *Selecting the search method* on this page.

2 Push and hold MULTI-CONTROL left or right to search every 10 tracks on a disc.

- If a disc contains less than 10 tracks, pushing and holding **MULTI-CONTROL** right recalls the last track of the disc. Also, if the remaining number of tracks after searching every 10 tracks is less than 10, pushing and holding **MULTI-CONTROL** right recalls the last track of the disc.

- If a disc contains less than 10 tracks, pushing and holding **MULTI-CONTROL** left recalls the first track of the disc. Also, if the remaining number of tracks after searching every 10 tracks is less than 10, pushing and holding **MULTI-CONTROL** left recalls the first track of the disc. 

Using disc title functions

You can input CD titles and display the title. The next time you insert a CD for which you have entered a title, the title of that CD will be displayed.

Use the disc title input feature to store up to 48 CD titles in the unit. Each title can be up to 10 characters long.

- When playing a CD TEXT disc, you cannot switch to disc title input display. The disc title will have already been recorded on a CD TEXT disc.

Entering disc titles

You can display the text information of any disc that has had a disc title entered.

1 Play the CD that you want to enter a title for.

2 Use MULTI-CONTROL to select Title Input in the function menu.
Title Input appears in the display.

3 Press DISPLAY to select the desired character type.

Press **DISPLAY** repeatedly to switch between the following character types:

Alphabet (upper case), numbers and symbols
—Alphabet (lower case)—European letters, such as those with accents (e.g. **á, à, ä, ç**)—
Numbers and symbols

4 Push MULTI-CONTROL up or down to select a letter of the alphabet.

Each time **MULTI-CONTROL** is pushed up, alphabet, numbers or symbols are displayed in ascending order (**A B C ...**). Each time **MULTI-CONTROL** is pushed down, letters are displayed in descending order.



5 Push MULTI-CONTROL right to move the cursor to the next character position.

When the letter you want is displayed, push **MULTI-CONTROL** right to move the cursor to the next position and then select the next letter. Push **MULTI-CONTROL** left to move backwards in the display.

6 Move the cursor to the last position by pushing MULTI-CONTROL right after entering the title.

When you push **MULTI-CONTROL** right one more time, the entered title is stored in memory.

7 Press BAND to return to the playback display.



Notes

- Titles remain in memory, even after the disc has been removed from the unit, and are recalled when the disc is reinserted.
- After data for 48 discs has been stored in memory, data for a new disc will overwrite the oldest one.
- If you connect a multi-CD player, you can input disc titles for up to 100 discs.
- When a multi-CD player that does not support disc title functions is connected, you cannot enter disc titles in this unit.

Built-in CD Player

Displaying disc titles

You can display the text information of any disc that has had a disc title entered.

- **Press DISPLAY.**

Press **DISPLAY** repeatedly to switch between the following settings:

: disc title—Simple display

Using CD TEXT functions

Some discs have certain information encoded on the disc during manufacture. These discs may contain such information as the CD title, track title, artist's name and playback time and are called CD TEXT discs. Only these specially encoded CD TEXT discs support the functions listed below.

Displaying text information on CD TEXT discs

You can display the text information of any disc that has had a disc title entered.

- **Press DISPLAY.**

Press **DISPLAY** repeatedly to switch between the following settings:

: disc title—: disc artist name—: track title—: track artist name—: disc title and : disc artist name—: track title and : track artist name—Simple display

- If specific information has not been recorded on a CD TEXT disc, title or name is not displayed.

Scrolling text information in the display

This unit can display the first 24 letters of disc title, disc artist name, track title and track artist name. When the text information is longer

than 24 letters, you can scroll the text information as follows.

- When the source icon is turned off, this unit can display the first 30 letters of text information.

- **Press DISPLAY and hold until the text information begins to scroll through the display.**

The titles scroll.



Note

When Ever Scroll is set to ON at the initial setting, text information scrolls continuously in the display. Refer to *Switching the Ever Scroll* on page 87.

Selecting tracks from the track title list

Track title list lets you see the list of track titles on a CD TEXT disc and select one of them to play back.

- 1 Press LIST to switch to the track title list mode.**

- 2 Use MULTI-CONTROL to select the desired track title.**

Turn to change the track title; press to play.

- You can also change the track title by pushing **MULTI-CONTROL** up or down.
- If you do not operate the list within about 30 seconds, the track title list mode is canceled automatically.

Playing MP3/WMA/AAC/WAV files

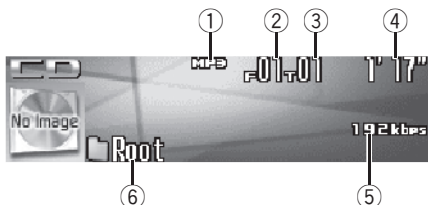

These are the basic steps necessary to play an MP3/WMA/AAC/WAV with your built-in CD player. More advanced MP3/WMA/AAC/WAV operation is explained starting on page 26.

- ① **MP3/WMA/AAC/WAV indicator**
Shows the type of file currently playing.
- ② **Folder number indicator**
Shows the folder number currently playing.
- ③ **Track number indicator**
Shows the track (file) number currently playing.
- ④ **Play time indicator**
Shows the elapsed playing time of the current track (file).
- ⑤ **Bit rate/sampling frequency indicator**
Shows the bit rate or sampling frequency of the current track (file).
- ⑥ **Folder name indicator**
Shows the name of the currently playing folder.

1 Press SOURCE to select the built-in CD player.

Press **SOURCE** until you see **Compact Disc** displayed.

- If no disc is loaded in the unit, you cannot select **Compact Disc** (built-in CD player). Insert a disc in the unit. (Refer to page 14.)

2 Push MULTI-CONTROL up or down to select a folder.

- You cannot select a folder that does not have an MP3/WMA/AAC/WAV file recorded in it.
- To return to folder 01 (ROOT), press and hold **BAND**. However, if folder 01 (ROOT) contains no files, playback commences with folder 02.

3 To perform fast forward or reverse, push and hold MULTI-CONTROL left or right.

- If you select **Rough search**, pushing and holding **MULTI-CONTROL** left or right enables you to search every 10 tracks in the current folder. (Refer to *Selecting the search method* on page 27.)

4 To skip back or forward to another track, push MULTI-CONTROL left or right.

Pushing **MULTI-CONTROL** right skips to the start of the next track. Pushing **MULTI-CONTROL** left once skips to the start of the current track. Pushing again will skip to the previous track.



Notes

- When playing discs with MP3/WMA/AAC/WAV files and audio data (CD-DA) such as CD-EXTRA and MIXED-MODE CDs, both types can be played only by switching mode between MP3/WMA/AAC/WAV and CD-DA with **BAND**.
- If you have switched between playback of MP3/WMA/AAC/WAV files and audio data (CD-DA), playback starts at the first track on the disc.
- The built-in CD player can play back an MP3/WMA/AAC/WAV file recorded on CD-ROM. (Refer to page 95 for files that can be played back.)

MP3/WMA/AAC/WAV Player

- Playback is carried out in order of file number. Folders are skipped if they contain no files. (If folder 01 (ROOT) contains no files, playback commences with folder 02.)
- When playing back files recorded as VBR (variable bit rate) files, the play time will not be correctly displayed if fast forward or reverse operations are used.
- When playing back MP3 files recorded as VBR (variable bit rate) files, the bit rate value is not displayed even after switching to bit rate. (**VBR** will be displayed.)
- When playing back WMA files recorded as VBR (variable bit rate) files, the average bit rate value is displayed.
- There is no sound on fast forward or reverse.
- When an MP3/WMA/AAC/WAV disc is inserted, folder name automatically begins to scroll in the display. When Ever Scroll is set to ON at the initial setting, folder name scrolls continuously. About Ever Scroll, refer to *Switching the Ever Scroll* on page 87. 



Note

After entering the number input mode, if you do not perform an operation within about eight seconds, the mode is automatically canceled. 

Selecting a track directly in the current folder

When using the remote control, you can select a track directly by entering the desired track number.

1 Press DIRECT.

Track number input display appears.

2 Press 0–9 buttons to enter the desired track number.

- You can cancel the input number by pressing **CLEAR**.

3 Press DIRECT.

The track of entered number will play.

Introduction of advanced built-in CD player (MP3/WMA/AAC/WAV) operation



① Function display

Shows the function status.

1 Press MULTI-CONTROL to display the main menu.

FUNCTION, **AUDIO** and **ENTERTAINMENT** appear on the display.

2 Use MULTI-CONTROL to select FUNCTION.

Turn to change the menu option; press to select.

The function name appears on the display.

3 Turn MULTI-CONTROL to select the function.

Turn **MULTI-CONTROL** clockwise or counter-clockwise to switch between the functions in the following order:

Play mode (repeat play)—**Random mode** (random play)—**Scan mode** (scan play)—**Pause** (pause)—**Search mode** (search method)—**Jacket art** (jacket art read)

- To return to the playback display, press **BAND**.



Note

If you do not operate the function within about 30 seconds, the display is automatically returned to the playback display. 

Repeating play

For MP3/WMA/AAC/WAV playback, there are three repeat play ranges: **Folder repeat** (folder repeat), **Track repeat** (one-track repeat) and **Disc repeat** (repeat all tracks).

1 Use MULTI-CONTROL to select Play mode in the function menu. Play mode appears in the display.

2 Press MULTI-CONTROL to select the repeat range.

Press **MULTI-CONTROL** repeatedly until the desired repeat range appears in the display.

- **Folder repeat** – Repeat the current folder
- **Track repeat** – Repeat just the current track
- **Disc repeat** – Repeat all tracks



Notes

- If you select another folder during repeat play, the repeat play range changes to **Disc repeat**.
- If you perform track search or fast forward/reverse during **Track repeat**, the repeat play range changes to **Folder repeat**.
- When **Folder repeat** is selected, it is not possible to play back a subfolder of that folder. 

Playing tracks in random order

Random play lets you play back tracks in a random order within the repeat range.

Folder repeat and **Disc repeat**.

1 Select the repeat range.

Refer to *Repeating play* on this page.

2 Use MULTI-CONTROL to select Random mode in the function menu. Random mode appears in the display.

MP3/WMA/AAC/WAV Player

3 Press MULTI-CONTROL to turn random play on.

Tracks will play in a random order within the previously selected **Folder repeat** or **Disc repeat** ranges.

- To turn random play off, press **MULTI-CONTROL** again. 

Scanning folders and tracks

While you are using **Folder repeat**, the beginning of each track in the selected folder plays for about 10 seconds. When you are using **Disc repeat**, the beginning of the first track of each folder is played for about 10 seconds.

1 Select the repeat range.

Refer to *Repeating play* on the previous page.

2 Use MULTI-CONTROL to select Scan mode in the function menu.

Scan mode appears in the display.

3 Press MULTI-CONTROL to turn scan play on.

The first 10 seconds of each track of the current folder (or the first track of each folder) is played.

4 When you find the desired track (or folder) press MULTI-CONTROL to turn scan play off.

The track (or folder) will continue to play.

- If the display has automatically returned to the playback display, select **Scan mode** again by using **MULTI-CONTROL**.



Note

After track or folder scanning is finished, normal playback of the tracks will begin again. 

Pausing MP3/WMA/AAC/WAV playback

Pause lets you temporarily stop playback of the MP3/WMA/AAC/WAV.

1 Use MULTI-CONTROL to select Pause in the function menu.

Pause appears in the display.

2 Press MULTI-CONTROL to turn pause on.

Playback of the current track pauses.

- To turn pause off, press **MULTI-CONTROL** again. 

Selecting the search method

You can switch the search method between fast forward/reverse and searching every 10 tracks.

1 Use MULTI-CONTROL to select Search mode in the function menu.

Search mode appears in the display.

2 Press MULTI-CONTROL to select the search method.

Press **MULTI-CONTROL** until the desired search method appears in the display.

- **FF/REV** – Fast forward and reverse
- **Rough search** – Searching every 10 tracks 

Searching every 10 tracks in the current folder

If the current folder contains over 10 tracks, you can search every 10 tracks. When one folder contains a lot of tracks, you can roughly search for the track you want to play.

1 Select the search method Rough search.

Refer to *Selecting the search method* on the previous page.

2 Push and hold MULTI-CONTROL left or right to search every 10 tracks in the current folder.

- If the current folder contains less than 10 tracks, pushing and holding **MULTI-CONTROL** right recalls the last track of the folder. Also, if the remaining number of tracks after searching every 10 tracks is less than 10, pushing and holding **MULTI-CONTROL** right recalls the last track of the folder.











- If the current folder contains less than 10 tracks, pushing and holding **MULTI-CONTROL** left recalls the first track of the folder. Also, if the remaining number of tracks after searching every 10 tracks is less than 10, pushing and holding **MULTI-CONTROL** left recalls the first track of the folder. 

Displaying text information on MP3/WMA/AAC/WAV disc

Text information recorded on an MP3/WMA/AAC/WAV disc can be displayed.

When playing back an MP3/WMA/AAC disc**● Press DISPLAY.**

Press **DISPLAY** repeatedly to switch between the following settings:

: folder name—: file name—: folder name and : file name—: artist name and : album title—: artist name and : track title—: comment and : file name—Simple display





- If specific information has not been recorded on an MP3/WMA/AAC disc, title or name is not displayed.

- Depending on the version of iTunes® used to write MP3 files onto a disc, comment information may not be correctly displayed.

- Depending on the version of Windows Media Player used to encode WMA files, album names and other text information may not be correctly displayed.

When playing back a WAV disc**● Press DISPLAY.**

Press **DISPLAY** repeatedly to switch between the following settings:

: folder name—: file name—: folder name and : file name—Simple display

- If specific information has not been recorded on a WAV disc, name is not displayed.
- You can only play back WAV files in the frequencies 16, 22.05, 24, 32, 44.1 and 48 kHz (LPCM), or 22.05 and 44.1 kHz (MS ADPCM). The sampling frequency shown in the display may be rounded. 

Scrolling text information in the display

This unit can display the first 24 letters only of folder name, file name, track title, artist name, album title and comment. When the recorded information is longer than 24 letters, you can scroll the text to the left so that the rest of the text information can be seen.

- When the jacket art is turned off, this unit can display the first 30 letters of text information.

● Press DISPLAY and hold until the text information begins to scroll through the display.

The text information scrolls.

MP3/WMA/AAC/WAV Player



Notes

- Unlike MP3, WMA and AAC file format, WAV files display only the folder name and the file name.
- When Ever Scroll is set to ON at the initial setting, text information scrolls continuously in the display. Refer to *Switching the Ever Scroll* on page 87.

Selecting tracks from the file name list

File name list lets you see the list of file names (or folder names) and select one of them to playback.

1 Press LIST to select the file name list mode.

Press **LIST** repeatedly to switch between the following lists:

Folder/file name list—jacket art list—playback display

2 Use MULTI-CONTROL to select the desired file name (or folder name).

Turn to change the name of file or folder; press to play; push right to see a list of the files (or folders) in the selected folder.

- You can also change the name of file or folder by pushing **MULTI-CONTROL** up or down.
- To return to the previous list (the folder one level higher), push **MULTI-CONTROL** left.
- If the folder/file number is more than 100, last 2-digit of the folder/file number is displayed.
- Number of the folders/files in the currently selected folder will be indicated on the right side of the display.
- If you do not operate the list within about 30 seconds, the file name list mode is canceled automatically.

Displaying jacket arts on CD-ROM discs

If jacket arts are recorded on CD-ROM disc, you can display them on this unit so you can easily find a specific folder looking at the jacket art.

- Record jacket arts for folders on CD-ROM in advance using your computer. For details, please visit the following site: <http://www.pioneer.co.jp/car/pclink4/index-e.html>
- Jacket arts (max. 15 images) directly beneath the ROOT folder can be read. If images have been recorded on the lower tier than the ROOT folder, these images are not displayed. In this case, preset images are displayed. Refer to *About folders and MP3/WMA/AAC/WAV files* on page 97.

Reading jacket arts

With this function on, jacket arts on CD-ROM disc are automatically read in this unit when the disc is inserted.

- Up to 15 jacket arts can be read in this unit.
- Reading jacket arts can take approx. 40 seconds. If the disc is reloaded, this unit read jacket arts again from the beginning.
- Jacket arts are not displayed if MIXED-MODE CD or partial CD is inserted into this unit.
- For other folders with no jacket arts recorded, this unit automatically assigns preset images to them.

1 Use MULTI-CONTROL to select Jacket art in the function menu.

Jacket art appears in the display.

2 Press MULTI-CONTROL to turn jacket art read on.

- To turn jacket art function off, press **MULTI-CONTROL** again.

Selecting folders with jacket arts

You can display the list of folders that are already assigned jacket arts and select one to start playback.

- In the jacket art list, this unit displays up to 15 folders with jacket arts.
- For other folders with no jacket arts recorded, this unit automatically assigns preset images to them.

1 Press LIST to select the jacket art list mode.

Press **LIST** repeatedly to switch between the following lists:

Folder/file name list—jacket art list—playback display

2 Push MULTI-CONTROL up or down to change the group of jacket art.

3 Use MULTI-CONTROL to select jacket art of the desired folder.

Turn to change the jacket art of folder; press to play.

- You can also change the jacket art of folder by pushing **MULTI-CONTROL** left or right.
- If you do not operate the list within about 30 seconds, the jacket art list mode is canceled automatically. 

Bluetooth Telephone

Hands-free phoning with cellular phones featuring Bluetooth wireless technology

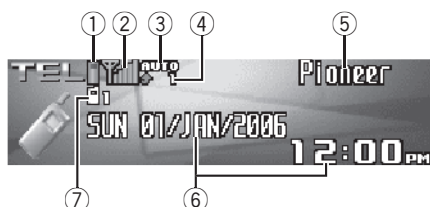

If your cellular phone features Bluetooth wireless technology, you can connect to this unit for hands-free, wireless calls, even while driving.

Important

- Since this unit is on standby to connect with your cellular phones via Bluetooth wireless technology, using this unit without running the engine can result in battery drainage.
- When phone is selected as a source, no audio adjustments, except balance adjustment, are possible.

① Battery strength indicator

Shows the battery strength of cellular phone.

- Battery strength indicator may differ from the actual battery strength.
- If the battery strength is not available, nothing is displayed in the battery strength indicator area.

② Signal level indicator

Shows the signal strength of cellular phone.

- Signal level indicator may differ from the actual signal level.
- Depending on the cellular phones featuring Bluetooth wireless technology, radio field intensity is not available. In this

case, the signal level indicator does not appear.

③ Automatic answering/Automatic rejecting indicator

Shows **AUTO** when the automatic answering function is on (for more details, refer to *Setting the automatic answering* on page 47).

Shows **REF** when the automatic rejecting function is on (for more details, refer to *Setting the automatic rejecting* on page 47).

④ Incoming call notice indicator

Shows when an incoming call has been received and not checked yet.

⑤ Device name

Shows the device name of the cellular phone.

⑥ Calendar display

Shows the date, and time.

⑦ User number indicator

Shows the registration number of the cellular phone.

Notes

- This unit's phone call reception is on standby when ignition switch is set to ACC or ON.
- The line-of-sight distance between this unit and your cellular phone must be 10 meters or less for sending and receiving voice and data via Bluetooth wireless technology. However, the transmission distance may become shorter than the estimated distance, depending on the environment in use.
- In order to use Bluetooth wireless technology, devices must be able to interpret certain profiles. This unit is compatible with the following profiles.
 - GAP (Generic Access Profile)
 - SDP (Service Discovery Protocol)

- OPP (Object Push Profile)
- HSP (Head Set Profile)
- HFP (Hands Free Profile)
- When phone is selected as a source, volume and equalizer curve are automatically changed to suitable settings for the phone source. When the source is returned to another source, volume and equalizer settings automatically return to the original setting.

About the telephone source

Standby mode

Once connected via Bluetooth wireless technology, this unit will remain on telephone source standby in the background all the while the connection is sustained. This means you can freely use the other functions of this unit, but still be ready to receive a call.

● Press **SOURCE** to select the telephone.

Press **SOURCE** until you see **Telephone** displayed.

- You can also select the **Telephone** by pressing **PHONE**.

Setting up for hands-free phoning

Before you can use the hands-free phoning function you will need to set up the unit for use with your cellular phone. This entails establishing a Bluetooth wireless connection between this unit and your phone, registering your phone with this unit, and adjusting the volume level.

1 Connection

For detailed instructions on connecting your phone to this unit via Bluetooth wireless tech-

nology, refer to *Connecting a cellular phone* on page 35.

- Your phone should now be temporarily connected; however, to make best use of the technology, we recommend you register the phone to this unit.

2 Registration

Refer to *Registering connected cellular phone* on page 37 for instructions on how to register your temporarily connected phone.

3 Volume adjustment

Adjust the earpiece volume on your cellular phone for comfort. When adjusted, the volume level is memorized in this unit as the default setting.

- Caller's voice volume and ring volume may vary depending on the type of cellular phones.
- If the difference between the ring volume and caller's voice volume is big, overall volume level may become unstable.
- Before disconnecting cellular phone from this unit, make sure to adjust the volume to proper level. If the volume has been muted (zero level) on your cellular phone, the volume level of your cellular phone remains muted even after the cellular phone is disconnected from this unit.

Bluetooth Telephone

Basic operation of hands-free phoning

These are the basic operations to use hands-free phoning via Bluetooth wireless technology. More advanced hands-free phoning operations are explained starting on *Introduction of advanced hands-free phoning operation* on page 35.

Making a phone call

Dial a number

The most basic way to make a call is to simply dial the number.

1 Press DIRECT on the remote control and dial a phone number by pressing 0–9.

2 Press JOYSTICK on the remote control to confirm the number.

3 Press OFF HOOK on the remote control to call the number.

- You can also dial a phone number in the function menu.

Refer to *Making a call by entering phone number* on page 45 for detailed instructions.

Calling a number in the Phone Book or the Call History

Refer to *Calling a number in the Phone Book* on page 40 and *Calling a number from the Call History* on page 45 for detailed instructions.

Preset number

Numbers that you dial frequently can be assigned to presets for quick recall. Refer to *Using preset numbers* on page 43 for how to assign a number to a preset.

1 Push MULTI-CONTROL up or down to select a preset number.

Preset numbers **Dial preset 1–10** appear in the display.

- You can also recall preset numbers **Dial preset 1–10** by pressing **0–9** on the remote control.
 - If the number is already in the Phone Book then the name is also displayed.
 - No data** is displayed for preset numbers that have not been assigned.

2 Press MULTI-CONTROL to make a call.

- You can also perform this operation by pressing **OFF HOOK** on the remote control.

Voice recognition

If your cellular phone features voice recognition technology, you can make a call by voice commands.

- Operation varies depending on the type of your cellular phone. Refer to the instruction manual that came with your cellular phone for detailed instructions.
- This function can be operated only when the connection is established with HFP (Hands Free Profile).

1 Press BAND and hold until Voice dial appears in the display.

Voice dial appears in the display. When **Voice dial ON** is displayed, voice recognition function is now ready.

- If your cellular phone does not feature voice recognition function, **No voice dial** appears in the display and operation is not available.

2 Pronounce the name of your contact.

For more details concerning the voice recognition operation, refer to your cellular phone's instruction manual.

Taking a phone call

Answering an incoming call

Even when a source other than **Telephone** is selected or when this unit itself is turned off, you can still answer incoming calls. If you set this unit to automatically answering incoming calls, refer to *Setting the automatic answering* on page 47.

1 When a call comes in, press **MULTI-CONTROL**.

- You can also perform this operation by pressing **OFF HOOK** on the remote control.
- If the private mode is selected on the cellular phone, hands-free phoning may not be performed.

2 To end the call, press **PHONE**.

The estimated call time appears in the display (this may differ slightly from the actual call time).

- You can also perform this operation by pressing **ON HOOK** on the remote control.
- You may hear a noise when you disconnect the phone.

Rejecting an incoming call

You can reject an incoming call. If you want to set this unit to automatically rejecting all incoming calls, refer to *Setting the automatic rejecting* on page 47.

● When a call comes in, press **PHONE**.

The call is rejected.

- You can also perform this operation by pressing **ON HOOK** on the remote control.
- The rejected call is recorded in missed call history list. About the missed call history list, refer to *Using the Call History* on page 44.

Answering a call waiting

If while you are talking on the phone another call comes in, the number (or name if it is in your phone book) of the new caller appears in the display to signal that you have a call waiting. You can put the first caller on hold while you answer the call waiting, or you can choose to reject the call, in which case the number is logged as a missed call.

1 Press **MULTI-CONTROL** to answer a call waiting.

- You can also perform this operation by pressing **OFF HOOK** on the remote control.
- Pressing **MULTI-CONTROL** switches between callers on hold.

2 Press **PHONE** to end all calls.

Pressing **PHONE** ends all calls including a call waiting on line.

- You can also perform this operation by pressing **ON HOOK** on the remote control.
- Except for switching between the calls on line, you cannot end each call waiting individually. Pressing **PHONE** ends all calls.

Rejecting a call waiting

If you would rather not interrupt your current call to answer a call waiting, you can reject it and have the number added to the missed call history list.

- With some cellular phones, this feature may not be possible.
- **Press **PHONE** to reject a call waiting.**
 - You can also perform this operation by pressing **ON HOOK** on the remote control. 

Bluetooth Telephone

Introduction of advanced hands-free phoning operation



① Function display

Shows the function status.

1 Press **MULTI-CONTROL** to display the main menu.

FUNCTION, **AUDIO** and **ENTERTAINMENT** appear on the display.

2 Use **MULTI-CONTROL** to select **FUNCTION**.

Turn to change the menu option; press to select.

Function names for hands-free phoning appear on the display.

3 Turn **MULTI-CONTROL** to change functions.

Turn **MULTI-CONTROL** clockwise or counter-clockwise to switch between the functions.

Function names that appear in the display are different depending on your cellular phone's connection and registration status.

If not connected yet

Search & connect (search and connect)—

Connection open (connection open)—

Connect phone (connect phone)—

Delete phone (delete phone)—

Phone book transfer (phone book transfer)—

Refuse calls (automatic reject setting)—

Auto answer (automatic answer setting)—

Ring tone (ring tone select)—**Auto connect** (automatic connection setting)—**Echo cancel** (echo cancel)—**Device INFO.** (device information)

If connected but not registered yet

Disconnect phone (disconnect phone)—

Set phone (registering phone)—

Delete phone (delete phone)—

Phone book transfer (phone book transfer)—

Number dial (call by entering number)—

Refuse calls (automatic reject setting)—

Auto answer (automatic answer setting)—

Ring tone (ring tone select)—**Auto connect** (automatic connection setting)—**Echo cancel** (echo cancel)—**Device INFO.** (device information)

If already connected and registered

Disconnect phone (disconnect phone)—

Delete phone (delete phone)—

Phone book transfer (phone book transfer)—

Phone book name view (phone book name view)—**Clear memory** (clear memory)—

Number dial (call by entering number)—

Refuse calls (automatic reject setting)—

Auto answer (automatic answer setting)—

Ring tone (ring tone select)—**Auto connect** (automatic connection setting)—**Echo cancel** (echo cancel)—**Telephone icon** (telephone icon)—**Device INFO.** (device information)

▪ **Phone book name view** and **Telephone icon** cannot be selected for cellular phone registered guest phone.

▪ If cellular phone is connected to this unit via Bluetooth wireless technology with HSP (Head Set Profile), **Phone book name view**, **Clear memory**, **Number dial** and **Refuse calls** cannot be selected.

▪ To return to the playback display, press **BAND**. 

▪ If cellular phone is connected to this unit via Bluetooth wireless technology with HSP (Head Set Profile), **Phone book name view**, **Clear memory**, **Number dial** and **Refuse calls** cannot be selected.

▪ To return to the playback display, press

BAND. 

Connecting a cellular phone

To use a phone wirelessly with this unit, it is necessary first to establish a connection using Bluetooth wireless technology. There are several ways you can do this.

Bluetooth Telephone

- Connection is normally established by HFP, which gives you a full control of functions available on the telephone source. However, in some cases when you make connection from your cellular phone, the connection may be made by HSP and several functions may not be available.
- A phone may be connected via Bluetooth wireless technology but not yet registered with this unit. In this case it is said to be temporarily connected, and the available features are limited. To take full advantage of all the features available, we recommend you register your phone with this unit. Refer to *Registering connected cellular phone* on the next page for more on this.

Searching for available cellular phones

You can have this unit search for any available phones in the area that have Bluetooth wireless technology, then select which you want to connect to from a list displayed on-screen.

1 Use MULTI-CONTROL to select Search & connect in the function menu. Search & connect appears in the display.

2 Press MULTI-CONTROL to search for available cellular phones.

While searching, **Searching** is displayed. When available cellular phones featuring Bluetooth wireless technology are found, device names or **Name not found** (if names cannot be obtained) are displayed.

- If this unit fails to find any available cellular phones, **Not found** is displayed.

3 Push MULTI-CONTROL up or down to select a device name you want to connect.

4 Press MULTI-CONTROL to connect the selected cellular phone.

While connecting, **Connecting** is displayed. To complete the connection, please check the device name (**Pioneer BT unit**) and enter the link code on your cellular phone. If the connection is established, **Connected** is displayed.

- The link code is set to **0000** as default. You can change this code in the initial setting. Refer to *Entering PIN code for Bluetooth wireless connection* on page 88.

Using a cellular phone to initiate a connection

Putting the unit in **Connection open** mode allows you to establish a Bluetooth wireless connection from your phone. You may need to refer to the operation manual that came with your phone if you are unsure how to initiate a connection from your phone.

1 Use MULTI-CONTROL to select Connection open in the function menu. Connection open appears in the display.

2 Press MULTI-CONTROL to open the connection.

Always waiting is displayed and the unit is now on standby for connection from cellular phone.

3 Use cellular phone to connect to this unit.

- Operation varies depending on the type of your cellular phone. Refer to the instruction manual that came with your cellular phone for detailed instructions.
- You may need to enter the link code on your cellular phone to complete the connection.

Bluetooth Telephone

- The link code is set to **0000** as default. You can change this code in the initial setting. Refer to *Entering PIN code for Bluetooth wireless connection* on page 88. 

Disconnecting a cellular phone

When you are done using your phone with this unit, you can close the Bluetooth wireless connection.

1 Use MULTI-CONTROL to select Disconnect phone in the function menu. **Disconnect phone**, and device name of the connected phone appear in the display.

2 Press MULTI-CONTROL to disconnect a cellular phone from this unit.

After the disconnection is completed, **Disconnected** is displayed. 

Registering connected cellular phone

You can register a phone that is temporarily connected to this unit in order to take full advantage of the features available with Bluetooth wireless technology. A total of five phones can be registered: three user cellular phones and two guest phones. When registered as a user phone, all the possible functions are available for use. When registered as a guest phone, some functions are limited.

1 Use MULTI-CONTROL to select Set phone in the function menu. **Set phone** appears in the display.

2 Push MULTI-CONTROL up or down to select a registration assignment.

Each time **MULTI-CONTROL** is pushed up or down, the registration assignment is switched in the following order:

Phone1 (user phone 1)—**Phone2** (user phone 2)—**Phone3** (user phone 3)—**Guest1** (guest phone 1)—**Guest2** (guest phone 2)

- As you select each assignment, you can see whether or not a phone is already registered there. If the assignment is empty, **No data** is displayed. If the assignment is already taken, the device name appears. If you want to replace an assignment with a new phone, first delete the current assignment. For more detailed instructions, see *Deleting a registered phone* on this page.

- If you need to know the BD (Bluetooth Device) address of the phone, push **MULTI-CONTROL** left here.

3 Press MULTI-CONTROL to register the cellular phone to this unit.

When the registration is completed, **Reg. completed** is displayed. 

Deleting a registered phone

If you no longer need to use a registered phone with this unit, you can delete it from the registration assignment for another phone.

- If a registered phone is deleted from this unit, the Phone Book and other settings of that phone are cleared simultaneously.

1 Use MULTI-CONTROL to select Delete phone in the function menu. **Delete phone** appears in the display.

Bluetooth Telephone

2 Push MULTI-CONTROL up or down to select a registration assignment.

Each time **MULTI-CONTROL** is pushed up or down, the registration assignment is switched in the following order:

Phone1 (user phone 1)—**Phone2** (user phone 2)—**Phone3** (user phone 3)—**Guest1** (guest phone 1)—**Guest2** (guest phone 2)

- If the assignment is empty, **No data** is displayed and the operation is not possible.
- If you need to know the BD (Bluetooth Device) address of the phone, push **MULTI-CONTROL** left here.

3 Push MULTI-CONTROL right to select Delete YES.

Delete YES is displayed. Deleting phone is now on standby.

4 Press MULTI-CONTROL to delete the phone.

After the phone is deleted, **Deleted** is displayed.

Connecting to a registered cellular phone

Once your phone is registered with this unit it is a simple matter to establish a Bluetooth wireless connection, either manually by selecting a registration assignment, or automatically when a registered phone is within range.

Connecting to a registered phone manually

Select a phone from the registration assignments to connect to the phone manually.

- 1 Use **MULTI-CONTROL** to select **Connect phone in the function menu**. **Connect phone** appears in the display.

2 Push MULTI-CONTROL up or down to select a registration assignment.

Each time **MULTI-CONTROL** is pushed up or down, the registration assignment is switched in the following order:

Phone1 (user phone 1)—**Phone2** (user phone 2)—**Phone3** (user phone 3)—**Guest1** (guest phone 1)—**Guest2** (guest phone 2)

- If the assignment is empty, **No data** is displayed and the operation is not possible.
- If you need to know the BD (Bluetooth Device) address of the phone, push **MULTI-CONTROL** left here.

3 Press MULTI-CONTROL to connect the selected cellular phone.

While connecting, **Connecting** is displayed. After the connection is completed, **Connected** is displayed.

Connecting to a registered phone automatically

When Automatic Connection is active the unit will automatically establish a connection with a registered phone when it comes into range.

- This feature may not work with all phones. If your registered phone fails to connect with Automatic Connection, use the manual connection method explained in *Connecting to a registered phone manually* on this page.
- This feature is not possible if you are playing back songs on your Bluetooth audio player via Bluetooth wireless technology. In such case, stop the playback and switch to another source for your cellular phone to connect to this unit through this function.
- While you are operating in the function menu of **Telephone** source or **BT Audio** source, this unit does not initiate an automatic connection to your registered phone.
- This feature cannot be set for each different user phone.

Bluetooth Telephone

1 Use MULTI-CONTROL to select Auto connect in the function menu.
Auto connect appears in the display.

2 Press MULTI-CONTROL to turn automatic connection on.

ON appears in the display.

If your cellular phone is set ready for Bluetooth wireless connection, the connection to this unit will be automatically established.

- To turn automatic connection off, press **MULTI-CONTROL** again.



Note

Automatic connection is performed in the registration number order. 

Using the Phone Book

The Phone Book can store up to 500 names and numbers. Use the Phone Book to browse for numbers on the unit's display and select numbers to call. Names and phone numbers stored in a registered user phone's address book can be transferred to the Phone Book, allowing you to fill the Phone Book quickly and easily with your contacts.

Transferring entries to the Phone Book

This function is available only for cellular phones registered to this unit as user. Phone books from guest phones cannot be transferred to this unit.

To populate the Phone Book you can transfer the numbers in a registered user phone's address book.

The Phone Book can hold a total of 500 entries; 300 from User 1, 150 from User 2, and 50 from User 3.

- With some cellular phones, it may not be possible to transfer whole phone book at a time. In this case, transfer phone book entries one by one from your phone by using your cellular phone.
- Depending on the cellular phone connected via Bluetooth wireless technology, this unit cannot display the Phone Book correctly. (Some characters may be garbled.)
- If the phone book in the cellular phone contains image data, phone book may not be correctly transferred.

1 Use MULTI-CONTROL to select Phone book transfer in the function menu.
Phone book transfer appears in the display.

2 Press MULTI-CONTROL to enter in the phone book transfer standby mode.
Transfer appears in the display.

- With **Telephone** source selected, you can also display the phone book transfer standby mode by pressing and holding **PHONE**.

3 Use cellular phone to perform phone book transfer.

Perform phone book transfer using the cellular phone. For detailed instruction on this, refer to the instruction manual that came with your cellular phone.

- While transferring the phone book, hourglass icon is displayed.
- The display indicates how many entries have been transferred and the total number to be transferred.

4 Data transferred is displayed and phone book transfer is completed.

Changing the Phone Book display order

You can choose to display the Phone Book sorted alphabetically by first name or last name.

- With some cellular phones, this feature may not be possible.

1 Use **MULTI-CONTROL** to select Phone book name view in the function menu.

Phone book name view appears in the display.

2 Press **MULTI-CONTROL** to change the name view order.

Inverted is displayed and the name view order is changed.

Pressing **MULTI-CONTROL** repeatedly changes the name view order between first name and last name.

Calling a number in the Phone Book

After finding the number in the Phone Book you want to call, you can select the entry and make the call.

1 Press **LIST** to display the Phone Book.

2 Push **MULTI-CONTROL** left or right to select the first letter of the name you are looking for.

Each time **MULTI-CONTROL** is pushed left or right alphabetical letters are changed.

- Turning **MULTI-CONTROL** clockwise or counterclockwise can also perform the same operation.

3 Press **MULTI-CONTROL** to display entries.

The display shows the first three Phone Book entries starting with that letter (e.g. "Ben", "Brian" and "Burt" when "B" is selected).

- If you want to go back and select another alphabetical letter, push **MULTI-CONTROL** left.

4 Push **MULTI-CONTROL** up or down to select a Phone Book entry you want to call.

Pushing **MULTI-CONTROL** up or down changes Phone Book entries.

5 Push **MULTI-CONTROL** right to display the detailed list of the selected entry.

The phone number, name and genre (if assigned) of entries are displayed in the detailed list.

- You can scroll the name and phone number by holding **DISPLAY**.
- If several phone numbers are entered to an entry, select one by turning **MULTI-CONTROL**.
- If you want to go back and select another entry, push **MULTI-CONTROL** left.

6 Press **MULTI-CONTROL** to make a call.

7 To end the call, press **PHONE**.

The estimated call time appears in the display (this may differ slightly from the actual call time).

Assign genres to phone numbers

If there are a lot of entries in the Phone Book it can be useful to assign them to specific genres (categories) for easier searching. There are four preset genres that you can assign entries to: **Home**, **Mobile**, **Office** and **Others**.

1 Press **LIST** to display the Phone Book.

Bluetooth Telephone

2 Use MULTI-CONTROL to display the detailed list of your desired Phone Book entry.

See step 2 to 5 on *Calling a number in the Phone Book* on the previous page for how to do this.

3 Press and hold MULTI-CONTROL to display the genre input screen.

Edit genre is displayed.

4 Push MULTI-CONTROL up or down to select a genre.

Each time **MULTI-CONTROL** is pushed up or down, the genres are switched in the following order:

Home (home)—**Mobile** (mobile)—**Office** (office)—**Others** (others)

5 Press MULTI-CONTROL to assign the genre to the phone number.

The selected genre is assigned to the phone number, and the display reverts to the detailed list.

Editing the name of a Phone Book entry

You can edit the names of Phone Book entries. Each name can be up to 40 characters long.

1 Press LIST to display the Phone Book.

2 Use MULTI-CONTROL to display the detailed list of your desired Phone Book entry.

See step 2 to 5 on *Calling a number in the Phone Book* on the previous page for how to do this.

3 Press and hold MULTI-CONTROL to display the genre input screen.

Edit genre is displayed.

4 Turn MULTI-CONTROL clockwise or counterclockwise to switch to the name input screen.

Turning **MULTI-CONTROL** switches input screens in the following order:

Edit genre (genre input screen)—**Edit name** (name input screen)—**Edit number** (number input screen)—**Edit icon** (icon selection screen)—**Clear memory** (clear memory screen)

5 Press DISPLAY to select the desired character type.

Each press of **DISPLAY** switches the character types in the following order:

Alphabet (upper case), numbers and symbols—alphabet (lower case)—numbers and symbols—European characters, such as those with accents (e.g., **á**, **à**, **ä**, **ç**) or Russian characters

- Pressing and holding **DISPLAY** enables you to switch character set between ISO8859-1 (European characters) and ISO8859-5 (Russian characters) alternately.
- European characters and Russian characters can't be mixed.

6 Push MULTI-CONTROL up or down to select a letter.

- To delete a character and leave a space, select " _ " (underbar).

7 Push MULTI-CONTROL right to move the cursor to the next character position.

When the letter you want is displayed, push **MULTI-CONTROL** right to move the cursor to the next position and then select the next letter. Push **MULTI-CONTROL** left to move backwards in the display.

8 Press MULTI-CONTROL to store the new name.

After the name is stored, the display reverts to the Phone Book entry list.

Editing phone numbers

You can edit the phone numbers of Phone Book entries.

- 1 Press LIST to display the Phone Book.**
- 2 Use MULTI-CONTROL to display the detailed list of your desired Phone Book entry.**
See step 2 to 5 on *Calling a number in the Phone Book* on page 40 for how to do this.
- 3 Press and hold MULTI-CONTROL to display the genre input screen.**
Edit genre is displayed.
- 4 Turn MULTI-CONTROL clockwise or counterclockwise to switch to the number input screen.**
Turning **MULTI-CONTROL** switches input screens in the following order:
Edit genre (genre input screen)—**Edit name** (name input screen)—**Edit number** (number input screen)—**Edit icon** (icon selection screen)—**Clear memory** (clear memory screen)
- 5 Push MULTI-CONTROL left or right to move the cursor to the number you want to change.**
- 6 Push MULTI-CONTROL up or down to change numbers.**
Repeat these steps until you have finished changing.
- 7 Press MULTI-CONTROL to store the new number.**

After the number is stored, the display reverts to the detailed list.

Selecting the icon of a Phone Book entry

You can select the icon of Phone Book entries. When you make a call or answer an incoming call, that icon is displayed.

- 1 Press LIST to display the Phone Book.**
- 2 Use MULTI-CONTROL to display the detailed list of your desired Phone Book entry.**
See step 2 to 5 on *Calling a number in the Phone Book* on page 40 for how to do this.
- 3 Press and hold MULTI-CONTROL to display the genre input screen.**
Edit genre is displayed.
- 4 Turn MULTI-CONTROL clockwise or counterclockwise to switch to the icon selection screen.**
Turning **MULTI-CONTROL** switches input screens in the following order:
Edit genre (genre input screen)—**Edit name** (name input screen)—**Edit number** (number input screen)—**Edit icon** (icon selection screen)—**Clear memory** (clear memory screen)
- 5 Push MULTI-CONTROL left or right to select an icon.**
Each time **MULTI-CONTROL** is pushed left or right, the icons are switched in the following order:
icon 1 (icon 1)—**icon 2** (icon 2)—**icon 3** (icon 3)—**icon 4** (icon 4)—**icon 5** (icon 5)
- 6 Press MULTI-CONTROL to assign the icon to the Phone Book entry.**

The selected icon is assigned to the Phone Book entry, and the display reverts to the detailed list.

Bluetooth Telephone



Note

You can rewrite icons of Phone Book entries. (Refer to *Rewriting the entertainment displays and the icons for telephone functions* on page 92.)

Clearing a Phone Book entry

You can delete Phone Book entries in the Phone Book one by one.

To clear all of your entries in the Phone Book, refer to *Clearing memory* on this page.

- 1 Press **LIST** to display the Phone Book.
- 2 Use **MULTI-CONTROL** to display the detailed list of your desired Phone Book entry.
- 3 Press and hold **MULTI-CONTROL** to display the genre input screen. **Edit genre** is displayed.
- 4 Turn **MULTI-CONTROL** clockwise or counterclockwise to switch to the clear memory screen.

Turning **MULTI-CONTROL** switches input screens in the following order:

Edit genre (genre input screen)—**Edit name** (name input screen)—**Edit number** (number input screen)—**Edit icon** (icon selection screen)—**Clear memory** (clear memory screen)

- 5 Push **MULTI-CONTROL** right to show a confirmation display.

Clear memory YES is displayed.

- If you do not want to clear memory that you have selected, push **MULTI-CONTROL** left. The display reverts.

- 6 Press **MULTI-CONTROL** to delete the Phone Book entry.

Cleared is displayed.

The Phone Book entry is deleted. The display returns to Phone Book entry list.

Using preset numbers

Assigning preset numbers

You can assign up to ten frequently called phone numbers to number presets (**Dial preset 1–10**).

- To call the number you assigned to preset, refer to *Preset number* on page 33.

- 1 Press **LIST** to display the Phone Book.
- 2 Use **MULTI-CONTROL** to display the detailed list of your desired Phone Book entry.
- 3 Press and hold one of **0–9** on the remote control to store the selected phone number in that preset.

Press 1 to store in **Dial preset 1**; 4 to store in **Dial preset 4**, etc. Press 0 to store in **Dial preset 10**. Hold the button down until you hear a beep.

- Up to 50 phone numbers (10 phone numbers for each of the three registered phones and two guest phones) can be stored in memory. 

Clearing memory

You can clear memory of each item; Phone Book, dialed/received/missed call history list and preset phone number.

1 Use **MULTI-CONTROL** to select **Clear memory** in the function menu.

Clear memory appears in the display.

2 Push **MULTI-CONTROL** up or down to select an item.

Each time **MULTI-CONTROL** is pushed up or down, the items are switched in the following order:

Phone book (phone book)—**Missed calls** (missed call history)—**Dialled calls** (dialled call history)—**Received calls** (received call history)—**Preset memory** (preset phone numbers)—**All clear** (delete all memory)

- If you select **All clear**, all memory regardless of items will be cleared.
- If guest phone is connected to this unit via Bluetooth wireless technology, **Phone book** cannot be selected.

3 Push **MULTI-CONTROL** right to determine the item that you want to delete from this unit.

Clear memory YES is displayed. Clearing memory is now on standby.

- If you do not want to clear memory that you have selected, push **MULTI-CONTROL** left. The display reverts.

4 Press **MULTI-CONTROL** to clear the memory.

Cleared is displayed and data on the selected item is cleared from this unit's memory. 

Using the Call History

The ten most recent calls made (dialled), received and missed, together with their times and dates, are stored in the Call History. You can browse the Call History and call numbers from it.

Displaying the Call History

The Call History is divided into three groups: Missed calls, Dialled calls, and Received calls. You can see the time and date of the call, as well as the number (and name if the number is in the Phone Book).

1 Press **LIST** to display the list.

Press **LIST** repeatedly to switch between the following lists:

PHONE BOOK (phone book)—**MISSED** (missed call)—**DIALLED** (dialled call)—**RECEIVED** (received call)

- About the Phone Book list, refer to *Using the Phone Book* on page 39.
- If no phone numbers have been stored in the selected list, **No Data** is displayed.

2 Turn **MULTI-CONTROL** to select a phone number.

Turning **MULTI-CONTROL** clockwise or counterclockwise to change the phone numbers stored in the list.

- If the number is already in the Phone Book the name is displayed.
- You can also change the phone number by pushing **MULTI-CONTROL** up or down.

3 Push **MULTI-CONTROL** right to display the detailed list.

Calling time and date, and phone number are displayed in the detailed list.

- If the number is already in the Phone Book then the name is also displayed.
- Turning **MULTI-CONTROL** clockwise or counterclockwise switches to the previous or next phone number displayed in the detailed list.
- If you do not operate anything within about 30 seconds, the list display is canceled automatically.

Bluetooth Telephone

Calling a number from the Call History

1 Display the list and select a phone number.

Display the phone number you want to make a call.

2 Push MULTI-CONTROL right to display the detailed list.

Calling time and date, and phone number are displayed in the detailed list.

- If the number is already in the Phone Book then the name is also displayed.

3 Press MULTI-CONTROL to make a call.

4 To end the call, press PHONE.

The estimated call time appears in the display (this may differ slightly from the actual call time).

Calling an international number from the Call History

When calling an international number stored in the Call History, precede the country code with a +.

1 With the detailed list displayed, press MULTI-CONTROL and hold to add +.

Pressing and holding MULTI-CONTROL adds + to the phone number.

- + can only be added when the detailed list of Missed call, Dialed call or Received call is selected.
- Pressing and holding MULTI-CONTROL again deletes +.

2 Press MULTI-CONTROL to make a call.

3 To end the call, press PHONE.

Assigning preset numbers

You can assign up to ten frequently called phone numbers to number presets (Dial preset 1–10).

1 Display the list and select a phone number.

Display the phone number you want to store in memory.

2 Push MULTI-CONTROL right to display the detailed list.

Calling time and date, and phone number are displayed in the detailed list.

3 Press and hold one of 0–9 on the remote control to store the selected phone number in that preset.

The selected phone number has been stored in memory. The next time you press the same preset button, the phone number is recalled from memory.

- Up to 50 phone numbers (10 phone numbers for each of the three registered phones and two guest phones) can be stored in memory. 

Making a call by entering phone number

You can make a call by directly entering phone numbers on this unit.

1 Use MULTI-CONTROL to select Number dial in the function menu. Number dial appears in the display.

- You can also enter in this menu from the standby display by pressing DIRECT on the remote control.

Bluetooth Telephone

2 Push MULTI-CONTROL up or down to select a number.

Pushing **MULTI-CONTROL** up repeatedly changes numbers in **0 1 2 ... 9 + # * _** order. Pushing it down changes in **_ * # + 9 ... 2 1 0** order.

- You can also input numbers by pressing **0-9** on the remote control.

3 Push MULTI-CONTROL right to move the cursor to the next position.

When the number you want is displayed, push **MULTI-CONTROL** right to move the cursor to the next position and then select the next number. Push **MULTI-CONTROL** left to move backwards in the display.

- Up to 24 digits can be entered.

4 If you have completed entering the number, press MULTI-CONTROL.

Call confirmation appears.

5 Press MULTI-CONTROL again to make a call.

While dialing, **Dialing** appears in the display.

6 To end the call, press PHONE.

The estimated call time appears in the display (this may differ slightly from the actual call time). 

Echo canceling and noise reduction

When you are operating hands-free phoning in the vehicle, you may hear undesired echo. This function reduces the echo and noise and keeps a certain sound quality.

- This feature cannot be set for each different user phone.

1 Use MULTI-CONTROL to select Echo cancel in the function menu.

Echo cancel appears in the display.

2 Press MULTI-CONTROL to turn echo canceling on.

ON appears in the display.

- To turn echo canceling off, press **MULTI-CONTROL** again. 

Changing the ring tone

The unit offers you to turn the ring tone for incoming calls on or off.

- The ring tone you select for this unit has no effect on the ring tone used by your phone. If you do not want your phone and this unit to ring at the same time, we recommend you turn the ring tone of one or the other off.

1 Use MULTI-CONTROL to select Ring tone in the function menu.

Ring tone appears in the display.

2 Push MULTI-CONTROL left or right to select a ring tone.

Each time **MULTI-CONTROL** is pushed left or right, the ring tone is selected in the following order:

OFF (ring tone off)—**Ring tone1** (ring tone 1)—**Ring tone2** (ring tone 2)—**Ring tone3** (ring tone 3)



Note

Ring tone3 differs depending on the situation of the source (on or off). 

Bluetooth Telephone

Setting the automatic rejecting

If this function is on, this unit automatically rejects all incoming calls.

- This feature cannot be set for each different user phone.

1 Use MULTI-CONTROL to select Refuse calls in the function menu.
Refuse calls appears in the display.

2 Press MULTI-CONTROL to turn automatic call rejection on.

ON appears in the display.

- To turn automatic call rejection off, press **MULTI-CONTROL** again. 

Setting the automatic answering

If this function is on, this unit automatically answers all incoming calls.

- This feature cannot be set for each different user phone.

1 Use MULTI-CONTROL to select Auto answer in the function menu.
Auto answer appears in the display.

2 Press MULTI-CONTROL to turn automatic answering on.

ON appears in the display.

- To turn automatic answering function off, press **MULTI-CONTROL** again.



Note

If both the automatic reject and automatic answer functions are set to ON, the automatic reject is prioritized and all incoming calls are automatically rejected. 

Selecting the icon for user phone

You can select one of icons to be displayed for telephone source.

A different icon can be assigned for each different user phone.

1 Use MULTI-CONTROL to select Telephone icon in the function menu.
Telephone icon appears in the display.

2 Push MULTI-CONTROL left or right to select an icon.

Each time **MULTI-CONTROL** is pushed left or right, the icons are switched in the following order:

icon 1 (icon 1)—**icon 2** (icon 2)—**icon 3** (icon 3)—**icon 4** (icon 4)—**icon 5** (icon 5)

3 Press MULTI-CONTROL to assign the icon to the user phone.

The selected icon is assigned to the user phone.



Note

You can rewrite icons for user phones. (Refer to *Rewriting the entertainment displays and the icons for telephone functions* on page 92.) 

Displaying BD (Bluetooth Device) address

Each device featuring Bluetooth wireless technology is allocated a unique 48-bit device address. Each device address consists of a 12-digit of hexadecimal string.

You can display the BD address of your cellular phone and this unit.

Displaying BD address of your cellular phone

1 Use MULTI-CONTROL to select Delete phone in the function menu.
Delete phone appears in the display.

2 Push MULTI-CONTROL up or down to select a registration assignment.
Each time **MULTI-CONTROL** is pushed up or down, the registration assignment is switched in the following order:

Phone1 (user phone 1)—**Phone2** (user phone 2)—**Phone3** (user phone 3)—**Guest1** (guest phone 1)—**Guest2** (guest phone 2)

- If the assignment is empty, **No data** is displayed and the operation is not possible.

3 Push MULTI-CONTROL left to switch to the BD address.

12-digit hexadecimal string is displayed.

- Pushing **MULTI-CONTROL** right returns to the device name.

4 Press BAND to return to the standby display.

Displaying BD address of this unit

1 Use MULTI-CONTROL to select Device INFO. in the function menu.

The device name (**Pioneer BT unit**) of this unit appears in the display.

2 Push MULTI-CONTROL left to switch to the BD address.

12-digit hexadecimal string is displayed.

- Pushing **MULTI-CONTROL** right returns to the device name.



Note

When you push **MULTI-CONTROL** down while the BD address (or the device name) of this unit is displayed, the system version of this unit ap-

pears. About the system version, refer to *Displaying system version for repair* on this page. 

Displaying system version for repair

Should this unit fails to operate properly and you consult with dealer for repair, you may be asked to indicate the system versions of this unit and of Bluetooth module. You can display the versions and confirm them.

1 Use MULTI-CONTROL to select Device INFO. in the function menu.

The device name (**Pioneer BT unit**) of this unit appears in the display.

2 Push MULTI-CONTROL down to switch to the system version of this unit.

The system (microprocessor) version of this unit is displayed.

- Pushing **MULTI-CONTROL** left displays the version of the Bluetooth module of this unit. Pushing **MULTI-CONTROL** right returns to the system version of this unit. 

Bluetooth Audio

Listening to songs on BT Audio (Bluetooth audio player)



You can use this unit to control a separately sold portable audio player featuring Bluetooth wireless technology (Bluetooth audio player). Even though your audio player does not contain a Bluetooth module, you can still control it from this unit via Bluetooth wireless technology using a Bluetooth adapter (sold separately).



Important

- This unit can control a Bluetooth audio player via A2DP or AVRCP profile. Bluetooth audio players (or Bluetooth adapters) compatible with those profiles can be connected to this unit.
 - A2DP profile (Advanced Audio Distribution Profile): Only playing back songs on your audio player is possible.
 - AVRCP profile (Audio/Video Remote Control Profile): Playing back, pausing, selecting songs, etc., are possible.
- Since there are a number of Bluetooth audio players available on the market, operations with your Bluetooth audio player using this unit vary in great range. Please refer to the instruction manual that came with your Bluetooth audio player as well as this manual while operating your player on this unit.
- Information about songs (e.g. the elapsed playing time, song title, song index, etc.) cannot be displayed on this unit.
- While you are listening to songs on your Bluetooth audio player, please refrain from operat-

ing on your cellular phone as much as possible. If you try operating on your cellular phone, the signal from your cellular phone may cause a noise on the song playback.

- When you are talking on the cellular phone connected to this unit via Bluetooth wireless technology, the song playback from your Bluetooth audio player connected to this unit is muted.
- Even if while you are listening to song on your Bluetooth audio player you switch to another source, the playback of song continues to elapse.

① Connection indicator

Shows the Bluetooth wireless connection status.

② Device name

Shows the device name of the connected Bluetooth audio player (or Bluetooth adapter).

● Press SOURCE to select Bluetooth audio player.

Press **SOURCE** until you see **BT Audio** displayed.

- If you cannot display **BT Audio**, first activate the BT audio source in the initial setting. For details, refer to *Activating the BT Audio source* on page 87.

Setting up for Bluetooth audio player

Before you can use Bluetooth audio player you will need to set up the unit for use.

1 Activation

Refer to *Activating the BT Audio source* on page 87 for instructions on how to turn the **BT Audio** on.

2 Connection

Refer to *Connecting a Bluetooth audio player* on this page on how to connect your Bluetooth audio player to this unit.

- Once connected via Bluetooth wireless technology, "Play", "Stop" and "Pause" on Bluetooth audio player can be operated in the **BT Audio** source.
- Before you can use audio players you may need to enter the PIN code into this unit. If your player requires a PIN code to establish a connection, look for the code on the player or in its accompanying documentation. Enter the PIN code referring to *Entering PIN code for Bluetooth wireless connection* on page 88. 

Connecting a Bluetooth audio player

For this unit to control your Bluetooth audio player it needs to establish a Bluetooth wireless connection.

This function initiates the connection via Bluetooth wireless technology.

1 Press **MULTI-CONTROL** to display the main menu.

FUNCTION, AUDIO and **ENTERTAINMENT** appear on the display.

2 Use **MULTI-CONTROL** to select **FUNCTION**.

Turn to change the menu option; press to select.

The function name appears on the display.

3 Turn **MULTI-CONTROL** to select **Connection open**.

4 Press **MULTI-CONTROL** to open the connection.

Always waiting is displayed. This unit is now on standby for connection from Bluetooth audio player.

5 Use your Bluetooth audio player to connect to this unit.

When the connection is successfully established, **Connected** is displayed.

- Operation varies depending on the type of your Bluetooth audio player. Refer to the instruction manual that came with your Bluetooth audio player for detailed instructions. 

Bluetooth Audio

Function operation

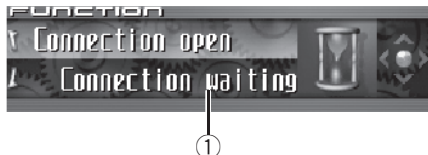

① Function display

Shows the function status.

Once connected via Bluetooth wireless technology, “Play”, “Stop” and other functions on Bluetooth audio player can be controlled from this unit’s function menu.

1 Press MULTI-CONTROL to display the main menu.

FUNCTION, **AUDIO** and **ENTERTAINMENT** appear on the display.

2 Use MULTI-CONTROL to select FUNCTION.

Turn to change the menu option; press to select.

The function name appears in the display.

3 Turn MULTI-CONTROL to select the function.

Turn **MULTI-CONTROL** clockwise or counter-clockwise to switch between the functions in the following order:

Disconnect audio (disconnect audio)—**Play** (Play)—**Stop** (Stop)—**Pause** (pause)—**Device INFO.** (device information)

- If a Bluetooth audio player is connected via A2DP profile, only **Disconnect audio** and **Device INFO.** appear in the function menu.
- If a Bluetooth audio player has not been connected to this unit yet, **Connection open** and **Device INFO.** appear in the function menu and other functions are not available.
- To return to the playback display, press **BAND**.



Notes

- If you do not operate the function within about 30 seconds, the display is automatically returned to the playback display.
- Depending on Bluetooth audio players connected to this unit, function operations may not be correctly operated. 

Playing songs on Bluetooth audio player

1 Use MULTI-CONTROL to select Play in the function menu.

Play appears in the display.

2 Press MULTI-CONTROL to start playback.

Pausing a song

Pause lets you temporarily stop playback of a song.

1 Use MULTI-CONTROL to select Pause in the function menu.

Pause appears in the display.

2 Press MULTI-CONTROL to turn pause on.

Playback of the current song pauses.

- To turn pause off, press **MULTI-CONTROL** again. 

Stopping playback

1 Use MULTI-CONTROL to select Stop in the function menu.

Stop appears in the display.

2 Press **MULTI-CONTROL** to stop the playback.

Playback of the current song stops. 

Disconnecting a Bluetooth audio player

When you are done using your Bluetooth audio player with this unit, you can close the Bluetooth wireless connection.

1 Use **MULTI-CONTROL** to select **Disconnect audio** in the function menu. **Disconnect audio** appears in the display.

2 Press **MULTI-CONTROL** to disconnect the Bluetooth audio player.

Disconnected is displayed. The Bluetooth audio player is now disconnected from this unit. 

Displaying BD address of this unit

Each device featuring Bluetooth wireless technology is allocated a unique 48-bit device address. Each device address consists of a 12-digit of hexadecimal string.

You can display the BD address of this unit.

1 Use **MULTI-CONTROL** to select **Device INFO.** in the function menu.

The device name (**Pioneer BT unit**) of this unit appears in the display.

2 Push **MULTI-CONTROL** left to switch to the BD address.

12-digit hexadecimal string is displayed.

- Pushing **MULTI-CONTROL** right returns to the device name.



Note

When you push **MULTI-CONTROL** down while the BD address (or the device name) of this unit is displayed, the system version of this unit appears. About the system version, refer to *Displaying system version for repair* on page 48. 

Displaying system version for repair

Should this unit fails to operate properly and you consult with dealer for repair, you may be asked to indicate the system versions of this unit and of Bluetooth module. You can display the versions and confirm them.

1 Use **MULTI-CONTROL** to select **Device INFO.** in the function menu.

The device name (**Pioneer BT unit**) of this unit appears in the display.

2 Push **MULTI-CONTROL** down to switch to the system version of this unit.

The system (microprocessor) version of this unit is displayed.

- Pushing **MULTI-CONTROL** left displays the version of the Bluetooth module of this unit. Pushing **MULTI-CONTROL** right returns to the system version of this unit. 

Multi-CD Player

Playing a CD

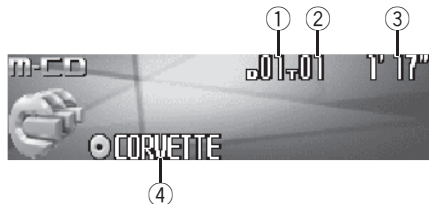

You can use this unit to control a multi-CD player, which is sold separately.

These are the basic steps necessary to play a CD with your multi-CD player. More advanced CD operation is explained starting on the next page.

- ① **Disc number indicator**
Shows the disc number currently playing.
- ② **Track number indicator**
Shows the track number currently playing.
- ③ **Play time indicator**
Shows the elapsed playing time of the current track.
- ④ **Disc title indicator**
Shows the title of the currently playing disc.
 - If no title has been entered for the currently playing disc, nothing is displayed.

1 Press SOURCE to select the multi-CD player.

Press **SOURCE** until you see **Multi-CD** displayed.

2 Push MULTI-CONTROL up or down to select a disc you want to listen to.

- You can also select a disc by using **1-6** buttons on the remote control.
 - For discs 1 to 6, press the corresponding button number.
 - For discs 7 to 12, press and hold the corresponding numbers, such as **1** for disc 7,

until the disc number appears in the display.

3 To perform fast forward or reverse, push and hold MULTI-CONTROL left or right.

4 To skip back or forward to another track, push MULTI-CONTROL left or right.

Pushing **MULTI-CONTROL** right skips to the start of the next track. Pushing **MULTI-CONTROL** left once skips to the start of the current track. Pushing again will skip to the previous track.



Notes

- When the multi-CD player performs the preparatory operations, **Ready** is displayed.
- If an error message such as **ERROR-11** is displayed, refer to the multi-CD player owner's manual.
- If there are no discs in the multi-CD player magazine, **No Disc** is displayed.
- When you select a CD TEXT disc on a CD TEXT compatible multi-CD player, the disc title automatically begins to scroll in the display. Ever Scroll function is ON at the initial setting, the disc title scrolls continuously. About Ever Scroll, refer to *Switching the Ever Scroll* on page 87. ■

Selecting a track directly

When using the remote control, you can select a track directly by entering the desired track number.

1 Press DIRECT.

Track number input display appears.

2 Press 0-9 buttons to enter the desired track number.

- You can cancel the input number by pressing **CLEAR**.

3 Press DIRECT.

The track of entered number will play.

**Note**

After entering the number input mode, if you do not perform an operation within about eight seconds, the mode is automatically canceled. □

50-disc multi-CD player

Only those functions described in this manual are supported by 50-disc multi-CD players. This unit is not designed to operate disc title list functions with a 50-disc multi-CD player. About the disc title list functions, please refer to *Selecting discs from the disc title list* on page 58. □

Introduction of advanced multi-CD player operation**① Function display**

Shows the function status.

1 Press MULTI-CONTROL to display the main menu.

FUNCTION, **AUDIO** and **ENTERTAINMENT** appear on the display.

2 Use MULTI-CONTROL to select FUNCTION.

Turn to change the menu option; press to select.

The function name appears on the display.

3 Turn MULTI-CONTROL to select the function.

Turn **MULTI-CONTROL** clockwise or counter-clockwise to switch between the functions in the following order:

Play mode (repeat play)—**Random mode** (random play)—**Scan mode** (scan play)—**Pause** (pause)—**ITS play mode** (ITS play)—**ITS memory** (ITS programming)—**Title Input** (disc title input)

- To return to the playback display, press **BAND**.

**Notes**

- When playing a CD TEXT disc on a CD TEXT compatible multi-CD player, you cannot switch to disc title input. The disc title will have already been recorded on a CD TEXT disc.

Multi-CD Player

- If you do not operate the function within about 30 seconds, the display is automatically returned to the playback display. 

Repeating play

There are three repeat play ranges for the multi-CD player: **Multi-CD repeat** (multi-CD player repeat), **Track repeat** (one-track repeat) and **Disc repeat** (disc repeat).

1 Use MULTI-CONTROL to select Play mode in the function menu.
Play mode appears in the display.

2 Press MULTI-CONTROL to select the repeat range.

Press **MULTI-CONTROL** repeatedly until the desired repeat range appears in the display.

- **Multi-CD repeat** – Repeat all discs in the multi-CD player
- **Track repeat** – Repeat just the current track
- **Disc repeat** – Repeat the current disc



Notes

- If you select other discs during repeat play, the repeat play range changes to **Multi-CD repeat**.
- If you perform track search or fast forward/reverse during **Track repeat**, the repeat play range changes to **Disc repeat**. 

Playing tracks in random order

Random play lets you play back tracks in random order within the repeat range, **Multi-CD repeat** and **Disc repeat**.

1 Select the repeat range.

Refer to *Repeating play* on this page.

2 Use MULTI-CONTROL to select Random mode in the function menu.
Random mode appears in the display.

3 Press MULTI-CONTROL to turn random play on.

Tracks will play in a random order within the previously selected **Multi-CD repeat** or **Disc repeat** ranges.

- To turn random play off, press **MULTI-CONTROL** again. 

Scanning CDs and tracks

While you are using **Disc repeat**, the beginning of each track on the selected disc plays for about 10 seconds. When you are using **Multi-CD repeat**, the beginning of the first track of each disc is played for about 10 seconds.

1 Select the repeat range.

Refer to *Repeating play* on this page.

2 Use MULTI-CONTROL to select Scan mode in the function menu.
Scan mode appears in the display.

3 Press MULTI-CONTROL to turn scan play on.

The first 10 seconds of each track of the current disc (or the first track of each disc) is played.

4 When you find the desired track (or disc) press MULTI-CONTROL to turn scan play off.

The track (or disc) will continue to play.

- If the display has automatically returned to the playback display, select **Scan mode** again by using **MULTI-CONTROL**.

**Note**

After track or disc scanning is finished, normal playback of the tracks will begin again. 

Pausing CD playback

Pause lets you temporarily stop playback of the CD.

1 Use MULTI-CONTROL to select Pause in the function menu.

Pause appears in the display.

2 Press MULTI-CONTROL to turn pause on.

Playback of the current track pauses.

- To turn pause off, press **MULTI-CONTROL** again. 

Using ITS playlists

ITS (instant track selection) lets you make a playlist of favorite tracks from those in the multi-CD player magazine. After you have added your favorite tracks to the playlist you can turn on ITS play and play just those selections.

Creating a playlist with ITS programming

You can use ITS to enter and play back up to 99 tracks per disc from up to 100 discs (with the disc titles). (With multi-CD players sold before the CDX-P1250 and CDX-P650, up to 24 tracks can be stored in the playlist.)

1 Play a CD that you want to program.

Push **MULTI-CONTROL** up or down to select the CD.

2 Use MULTI-CONTROL to select ITS memory in the function menu. ITS memory appears in the display.

3 Select the desired track by pushing MULTI-CONTROL left or right.

4 Push MULTI-CONTROL up to store the currently playing track in the playlist. Memory complete is displayed and the currently playing selection is added to your playlist.

5 Press BAND to return to the playback display.

**Note**

After data for 100 discs has been stored in memory, data for a new disc will overwrite the oldest one.

Playback from your ITS playlist

ITS play lets you listen to the tracks that you have entered into your ITS playlist. When you turn on ITS play, tracks from your ITS playlist in the multi-CD player will begin to play.

1 Select the repeat range.

Refer to *Repeating play* on the previous page.

2 Use MULTI-CONTROL to select ITS play mode in the function menu. ITS play mode appears in the display.

3 Press MULTI-CONTROL to turn ITS play on.

Playback begins of those tracks from your playlist within the previously selected **Multi-CD repeat** or **Disc repeat** ranges.

- If no tracks in the current range are programmed for ITS play, then **ITS empty** is displayed.
- To turn ITS play off, press **MULTI-CONTROL** again.

Multi-CD Player

Erasing a track from your ITS playlist

You can delete a track from your ITS playlist if ITS play is on.

If ITS play is already on, skip to step 2. If ITS play is not already on, use **MULTI-CONTROL**.

1 Play the CD with the track you want to delete from your ITS playlist, and turn ITS play on.

Refer to *Playback from your ITS playlist* on the previous page.

2 Use **MULTI-CONTROL** to select ITS memory in the function menu. ITS memory appears in the display.

3 Select the desired track by pushing **MULTI-CONTROL** left or right.

4 Push **MULTI-CONTROL** down to erase the track from your ITS playlist.

The currently playing selection is erased from your ITS playlist and playback of the next track from your ITS playlist begins.

- If there are no tracks from your playlist in the current range, **ITS empty** is displayed and normal play resumes.

5 Press **BAND** to return to the playback display.

Erasing a CD from your ITS playlist

You can delete all tracks of a CD from your ITS playlist if ITS play is off.

1 Play the CD that you want to delete.

Push **MULTI-CONTROL** up or down to select the CD.

2 Use **MULTI-CONTROL** to select ITS memory in the function menu. ITS memory appears in the display.

3 Push **MULTI-CONTROL** down to erase all tracks on the currently playing CD from your ITS playlist.

All tracks on the currently playing CD are erased from your playlist and **Memory deleted** is displayed.

4 Press **BAND** to return to the playback display.

Using disc title functions

You can input CD titles and display the titles. Then you can easily search for and play a desired disc.

Entering disc titles

Use the disc title input feature to store up to 100 CD titles (with ITS playlist) into the multi-CD player. Each title can be up to 10 characters long.

1 Play the CD that you want to enter a title for.

Push **MULTI-CONTROL** up or down to select the CD.

2 Use **MULTI-CONTROL** to select Title Input in the function menu. Title Input appears in the display.

3 Press **DISPLAY** to select the desired character type.

Press **DISPLAY** repeatedly to switch between the following character types:

Alphabet (upper case), numbers and symbols —Alphabet (lower case)—European letters, such as those with accents (e.g. **á, à, â, ç**)—Numbers and symbols

Multi-CD Player

4 Push MULTI-CONTROL up or down to select a letter of the alphabet.

Each time **MULTI-CONTROL** is pushed up, alphabet, numbers or symbols are displayed in ascending order (**A B C ...**). Each time **MULTI-CONTROL** is pushed down, letters are displayed in descending order.



5 Push MULTI-CONTROL right to move the cursor to the next character position.

When the letter you want is displayed, push **MULTI-CONTROL** right to move the cursor to the next position and then select the next letter. Push **MULTI-CONTROL** left to move backwards in the display.

6 Move the cursor to the last position by pushing MULTI-CONTROL right after entering the title.

When you push **MULTI-CONTROL** right one more time, the entered title is stored in memory.

7 Press BAND to return to the playback display.



Notes

- Titles remain in memory, even after the disc has been removed from the magazine, and are recalled when the disc is reinserted.
- After data for 100 discs has been stored in memory, data for a new disc will overwrite the oldest one.

Displaying disc titles

You can display the text information of any disc that has had a disc title entered.

● Press DISPLAY.

Press **DISPLAY** repeatedly to switch between the following settings:

- ☉: disc title—Simple display

Selecting discs from the disc title list

Disc title list lets you see the list of disc titles that have been entered into the multi-CD player and select one of them to play back.

1 Press LIST to switch to the disc title list mode during the playback display.

2 Use MULTI-CONTROL to select the desired disc title.

Turn to change the disc title; press to play.

- You can also change the disc title by pushing **MULTI-CONTROL** up or down.
- If no title has been entered for a disc,

No D.Title will be displayed.

- **No Disc** is displayed next to the disc number when there is no disc in the magazine.
- If you do not operate the list within about 30 seconds, the disc title list mode is canceled automatically. [■]

Using CD TEXT functions

You can use these functions only with a CD TEXT compatible multi-CD player.

Some discs have certain information encoded on the disc during manufacture. These discs may contain such information as the CD title, track title, artist's name and playback time and are called CD TEXT discs. Only these specially encoded CD TEXT discs support the functions listed below.

Multi-CD Player

Displaying text information on CD TEXT discs

● Press DISPLAY.

Press **DISPLAY** repeatedly to switch between the following settings:

: disc title—: disc artist name—: track title—: track artist name—: disc title and : disc artist name—: track title and : track artist name—Simple display

■ If specific information has not been recorded on a CD TEXT disc, title or name is not displayed.

Scrolling text information in the display

This unit can display the first 24 letters of disc title, disc artist name, track title and track artist name. When the text information is longer than 24 letters, you can scroll the text information as follows.

- When the source icon is turned off, this unit can display the first 30 letters of text information.

● Press DISPLAY and hold until the text information begins to scroll through the display.

The titles scroll.

Note

When Ever Scroll is set to ON at the initial setting, text information scrolls continuously in the display. Refer to *Switching the Ever Scroll* on page 87.

Selecting tracks from the track title list

Track title list lets you see the list of track titles on a CD TEXT disc and select one of them to play back.

1 Press LIST to switch to the disc title list mode during the playback display.

■ If you want to display the track title list of the currently playing disc, push **MULTI-CONTROL** right.

2 Use MULTI-CONTROL to select the desired disc title of CD TEXT.

Turn to change the disc title; press to play.

■ You can also change the disc title by pushing **MULTI-CONTROL** up or down.

■ If no title has been entered for a disc,

No D.Title will be displayed.

■ **No Disc** is displayed next to the disc number when there is no disc in the magazine.

3 Push MULTI-CONTROL right to switch to the track title list.

■ Push **MULTI-CONTROL** left to return to the disc title list.

4 Use MULTI-CONTROL to select the desired track title.

Turn to change the track title; press to play.

■ You can also change the track title by pushing **MULTI-CONTROL** up or down.

■ If you do not operate the list within about 30 seconds, the track title list mode is canceled automatically.

Listening to songs on your iPod

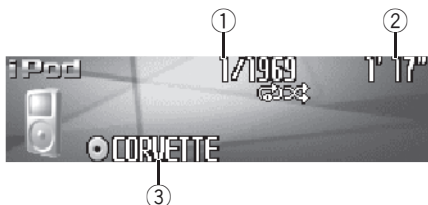

You can use this unit to control an iPod adapter, which is sold separately.

These are the basic steps necessary to operate an iPod adapter. More advanced iPod adapter operation is explained starting on *Introduction of advanced iPod adapter operation* on page 62.

① Song number indicator

Shows the number of song played in the selected list.

② Play time indicator

Shows the elapsed playing time of the current song.

③ Album title indicator

Shows the title of the currently playing album.

1 Press SOURCE to select the iPod.

Press **SOURCE** until you see **iPod** displayed.

2 To perform fast forward or reverse, push and hold MULTI-CONTROL left or right.

3 To skip back or forward to another song, push MULTI-CONTROL left or right.

Pushing **MULTI-CONTROL** right skips to the start of the next song. Pushing **MULTI-CONTROL** left once skips to the start

of the current song. Pushing again will skip to the previous song.

Browsing for a song

The operation of this unit to control an iPod is designed to be as close to the operation of the iPod as possible for easy operation and song search.

1 Press LIST to switch to the top menu of the list search.

2 Use MULTI-CONTROL to select a category.

Turn to change the category; press to select.

Playlists (playlists)—**Artists** (artists)—**Albums** (albums)—**Songs** (songs)—**Genres** (genres)

List from the selected category is displayed.

- You can start playback throughout the selected category by pressing and holding

MULTI-CONTROL.

- You can also change the category by pushing **MULTI-CONTROL** up or down.

- You can also select the category by pushing **MULTI-CONTROL** right.

- To return to the previous list, push

MULTI-CONTROL left.

- To go to the top menu of the list search, push and hold **MULTI-CONTROL** left.

- If you do not operate the list within about 30 seconds, the list search is cancelled automatically.

Playing songs on iPod

Searching for a song

1 Press LIST to switch to the top menu of the list search.

2 Use MULTI-CONTROL to select a Genres, Artists, Albums or Songs from among the categories.

Turn to change the category; press to select. List from the selected category is displayed.

3 Use MULTI-CONTROL to select a song, album, artist or genre.

Turn to change the item; press to select. List from the selected item is displayed.

- If you select **Songs** (songs), playback starts instantly from the selected one.

4 Repeat step 3 to find a song you want to listen to.

Selecting a playlist

You can select a playlist from your iPod playlist.

1 Press LIST to switch to the top menu of the list search.

2 Use MULTI-CONTROL to select a Playlists from among the categories.

Turn to change the category; press to select. List from **Playlists** (playlists) is displayed.

3 Use MULTI-CONTROL to select a playlist.

Turn to change the playlist; press to select. Song list from the selected playlist is displayed.

- You can start playback throughout the selected playlist by pressing and holding **MULTI-CONTROL**.

4 Use MULTI-CONTROL to select a song from the selected playlist.

Turn to change the song; press to play.









- If no songs have been stored in playlist, **STOP** is displayed and playback stops. 

Displaying text information on iPod

Text information recorded on the iPod can be displayed.

● Press DISPLAY.

Press **DISPLAY** repeatedly to switch between the following settings:

: album title—: song title—: artist name—: artist name and : album title—: song title and : artist name—: song title and : album title—Simple display

- If the characters recorded on the iPod are not compatible with this unit, those characters will not be displayed.



Notes

- You can scroll to the left the text information by pressing and holding **DISPLAY**.
- When Ever Scroll is set to ON at the initial setting, text information scrolls continuously in the display. Refer to *Switching the Ever Scroll* on page 87. 

Introduction of advanced iPod adapter operation



① Function display

Shows the function status.

1 Press MULTI-CONTROL to display the main menu.

FUNCTION, **AUDIO** and **ENTERTAINMENT** appear on the display.

2 Use MULTI-CONTROL to select FUNCTION.

Turn to change the menu option; press to select.

The function name appears on the display.

3 Turn MULTI-CONTROL to select the function.

Turn **MULTI-CONTROL** clockwise or counter-clockwise to switch between the functions in the following order:

Play mode (repeat play)—**Shuffle mode** (random play)—**Pause** (pause)

- To return to the playback display, press **BAND**.

Note

If you do not operate the function within about 30 seconds, the display is automatically returned to the playback display. 

Repeating play

For playback of the songs on the iPod, there are two repeat play ranges: **Repeat one** (re-

peat one song) and **Repeat all** (repeat all songs in the list).

- While **Play mode** is set to **Repeat one**, you cannot select the other songs.

1 Use MULTI-CONTROL to select Play mode in the function menu. Play mode appears in the display.

2 Press MULTI-CONTROL to select the repeat range.

Press **MULTI-CONTROL** repeatedly until the desired repeat range appears in the display.

- **Repeat one** – Repeat just the current song
- **Repeat all** – Repeat all songs in the selected list 

Playing songs in a random order (shuffle)

For playback of the songs on the iPod, there are two random play methods: **Shuffle Songs** (play back songs in a random order) and **Shuffle Albums** (play back albums in a random order).

1 Use MULTI-CONTROL to select Shuffle mode in the function menu. Shuffle mode appears in the display.

2 Press MULTI-CONTROL to select your favorite setting.

Press **MULTI-CONTROL** repeatedly until the desired setting appears in the display.

- **Shuffle Songs** – Play back songs in a random order within the selected list
- **Shuffle Albums** – Select an album randomly, and then play back all the songs in it in order
- **Shuffle OFF** – Cancel the random play 

Playing songs on iPod

Pausing a song

Pause lets you temporarily stop playback of a song.

1 Use MULTI-CONTROL to select Pause in the function menu.

Pause appears in the display.

2 Press MULTI-CONTROL to turn pause on.

Playback of the current song pauses.

- To turn pause off, press **MULTI-CONTROL** again. 

Watching the television

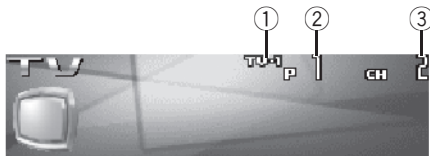

You can use this unit to control a TV tuner, which is sold separately.

For details concerning operation, refer to the TV tuner's operation manual. This section provides information on TV operations with this unit which differs from that described in the TV tuner's operation manual.

① Band indicator

Shows which band the TV tuner is tuned to.

② Preset number indicator

Shows which preset has been selected.

③ Channel indicator

Shows which channel the TV tuner is tuned to.

1 Press SOURCE to select the TV.

Press **SOURCE** until you see **Television** displayed.

2 Press BAND to select a band.

Press **BAND** until the desired band is displayed, **TV-1** or **TV-2**.

3 To perform manual tuning, push MULTI-CONTROL left or right.

The channels move up or down step by step.

4 To perform seek tuning, push and hold MULTI-CONTROL left or right for about one second and release.

The tuner will scan the channels until a broadcast strong enough for good reception is found.

- You can cancel seek tuning by pushing **MULTI-CONTROL** left or right.
- If you push and hold **MULTI-CONTROL** left or right, you can skip broadcasting channels. Seek tuning starts as soon as you release **MULTI-CONTROL**. 

TV tuner

Introduction of advanced TV tuner operation



① Function display

Shows the function status.

1 Press MULTI-CONTROL to display the main menu.

FUNCTION, **AUDIO** and **ENTERTAINMENT** appear on the display.

2 Use MULTI-CONTROL to select FUNCTION.

BSSM appears on the display.

- To return to the channel display, press **BAND**.

Note

If you do not operate the function within about 30 seconds, the display is automatically returned to the channel display. 

Storing and recalling broadcast stations

You can easily store up to 12 broadcast stations for later recall.

1 When you find a station that you want to store in memory press LIST to switch to the preset channel list mode.

2 Use MULTI-CONTROL to store the selected station in memory.

Turn to change the preset number; press and hold to store.

The preset number you have selected will flash and then remain lit. The selected station has been stored in memory.

- If you do not operate the list within about 30 seconds, the preset channel list mode is canceled automatically.



Notes

- Up to 24 stations, 12 for each of two TV bands, can be stored in memory.
- You can also store stations assigned to preset tuning numbers **1-6** by pressing and holding one of the preset tuning buttons **1-6** on the remote control. 

Storing the strongest broadcast stations sequentially

1 Use MULTI-CONTROL and select FUNCTION to display BSSM.

2 Press MULTI-CONTROL to turn BSSM on.

Searching is displayed. While **Searching** is displayed, the 12 strongest broadcast stations will be stored in order from the lowest channel up. When finished, the preset channel list appears.

- To cancel the storage process, press **MULTI-CONTROL**.

3 Use MULTI-CONTROL to select the desired station.

Turn to change the station; press to select.

- You can also change the station by pushing **MULTI-CONTROL** up or down.

- If you do not operate the list within about 30 seconds, the preset channel list mode is canceled automatically.

**Note**

Storing broadcast stations with BSSM may replace broadcast stations you have saved using **P01–P12**. 

Selecting stations from the preset channel list

The preset channel list lets you see the list of preset stations and select one of them to receive.

1 Press **LIST** to switch to the preset channel list mode during the channel display.

2 Use **MULTI-CONTROL** to select the desired station.

Turn to change the station; press to select.

- You can also change the station by pushing **MULTI-CONTROL** up or down.
- If you do not operate the list within about 30 seconds, the preset channel list mode is canceled automatically.

**Notes**

- You can also recall stations assigned to preset tuning numbers by pushing **MULTI-CONTROL** up or down during the channel display.
- You can also recall stations assigned to preset tuning numbers **1–6** by pressing one of the preset tuning buttons **1–6** on the remote control. 

DVD Player

Playing a disc

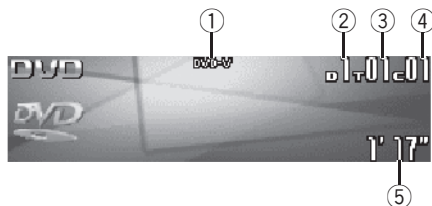

You can use this unit to control a DVD player or multi-DVD player, which is sold separately.

For details concerning operation, refer to the DVD player's or multi-DVD player's operation manual. This section provides information on DVD operations with this unit which differs from that described in the DVD player's or multi-DVD player's operation manual.

These are the basic steps necessary to play a DVD video with your DVD player. More advanced DVD video operation is explained starting on the next page.

① DVD-V/VCD/CD/MP3/WMA indicator

Shows the type of disc currently playing.

② Disc number indicator

Shows the disc number currently playing when using a multi-DVD player.

③ Title/Folder/Disc number indicator

Shows the title (when playing DVD video), folder (when playing MP3 or WMA) or disc (when playing video CD or CD) of the selection currently playing.

④ Chapter/track number indicator

Shows the chapter (when playing DVD video) or track (when playing video CD, CD, MP3 or WMA) currently playing.

⑤ Play time indicator

Shows the elapsed playing time of the current track.

1 Press SOURCE to select the DVD player/multi-DVD player.

Press **SOURCE** until you see **DVD** displayed.

2 To perform fast forward or reverse, push and hold MULTI-CONTROL left or right.

3 To skip back or forward to another chapter/track, push MULTI-CONTROL left or right.

Selecting a disc

- You can operate this function only when a multi-DVD player is connected to this unit.
- Push **MULTI-CONTROL** up or down to select the desired disc.

Selecting a folder

- You can operate this function only when a DVD player which is corresponding to MP3/WMA playback is connected to this unit.
- Push **MULTI-CONTROL** up or down to select a folder.

Introduction of advanced DVD player operation



① Function display

Shows the function status.

1 Press MULTI-CONTROL to display the main menu.

FUNCTION, **AUDIO** and **ENTERTAINMENT** appear on the display.

2 Use MULTI-CONTROL to select **FUNCTION**.

Turn to change the menu option; press to select.

The function name appears on the display.

3 Turn MULTI-CONTROL to select the function.

Turn **MULTI-CONTROL** clockwise or counter-clockwise to switch between the functions in the following order:

During DVD video or Video CD playback

Play mode (repeat play)—**Pause** (pause)

During CD playback

Play mode (repeat play)—**Random mode**

(random play)—**Scan mode** (scan play)—

Pause (pause)—**ITS play mode** (ITS play)—

ITS memory (ITS input)—**Title Input** (disc

title input)

During MP3/WMA playback

Play mode (repeat play)—**Random mode**

(random play)—**Scan mode** (scan play)—

Pause (pause)

- To return to the playback display, press **BAND**.



Note

When using this unit with multi-DVD player, you can switch to **ITS play mode**, **ITS memory** and **Title Input**. 

Repeating play

- During PBC playback of Video CDs, this function cannot be operated.

1 Use **MULTI-CONTROL** to select **Play mode** in the function menu.

Play mode appears in the display.

2 Press **MULTI-CONTROL** to select the repeat range.

During DVD video playback

Press **MULTI-CONTROL** repeatedly until the desired repeat range appears in the display.

- **Disc repeat** – Repeat the current disc
- **Chapter repeat** – Repeat just the current chapter
- **Title repeat** – Repeat just the current title

During Video CD or CD playback

Press **MULTI-CONTROL** repeatedly until the desired repeat range appears in the display.

- **Disc repeat** – Repeat the current disc
- **Track repeat** – Repeat just the current track

During MP3/WMA playback

Press **MULTI-CONTROL** repeatedly until the desired repeat range appears in the display.

- **Disc repeat** – Repeat the current disc
- **Folder repeat** – Repeat the current folder
- **Track repeat** – Repeat just the current track



Notes

- If you select other discs during repeat play, the repeat play range changes to **Disc repeat**.

DVD Player

- During video CD or CD playback, if you perform track search or fast forward/reverse during **Track repeat**, the repeat play range changes to **Disc repeat**.
- During MP3/WMA playback, if you select another folder during repeat play, the repeat play range changes to **Disc repeat**.
- During MP3/WMA playback, if you perform track search or fast forward/reverse during **Track repeat**, the repeat play range changes to **Folder repeat**. 

Pausing disc playback

1 Use MULTI-CONTROL to select Pause in the function menu.

Pause appears in the display.

2 Press MULTI-CONTROL to turn pause on.

Playback of the current track pauses.

- To turn pause off, press **MULTI-CONTROL** again. 

Playing tracks in random order

- You can operate this function during CD/MP3/WMA playback.

1 Use MULTI-CONTROL to select Random mode in the function menu.

Random mode appears in the display.

2 Press MULTI-CONTROL to turn random play on.

Tracks will play in a random order.

- To turn random play off, press **MULTI-CONTROL** again. 

Scanning tracks of a CD/MP3/WMA

- You can operate this function during CD/MP3/WMA playback.

1 Use MULTI-CONTROL to select Scan mode in the function menu.

Scan mode appears in the display.

2 Press MULTI-CONTROL to turn scan play on.

The first 10 seconds of each track is played.

3 When you find the desired track press MULTI-CONTROL to turn scan play off.

The track will continue to play.

- If the display has automatically returned to the playback display, select **Scan mode** again by using **MULTI-CONTROL**. 

Using ITS playlist and disc title functions

- You can operate these functions only when a multi-DVD player is connected to this unit.
- This function differs slightly from ITS playback with a multi-CD player. With multi-DVD player, ITS playback applies only to the CD playing. For details, refer to *Using ITS playlists* on page 56. 

Using disc title functions

You can input CD titles and display the titles. Then you can easily search for and play a desired disc.

- You can operate this function during CD playback.

Entering disc titles

Disc title input lets you input CD titles up to 10 letters long into the DVD player. For details concerning operation, refer to *Entering disc titles* on page 57.

- You can operate this function only when a DVD player is connected to this unit.
- When playing a CD TEXT disc on a CD TEXT compatible DVD player, you cannot switch to disc title input. The disc title will have already been recorded on a CD TEXT disc.

Audio Adjustments

Adjusting the audio easily

The following functions let you easily adjust your audio system to match the car interior acoustic characteristics, which vary depending on the type of car.

- *Recalling equalizer curves*
- *Using the position selector (Position)*
- *Adjusting equalizer curves* 

Adjusting the audio finely

By carrying out the following settings/adjustments in the order shown, you can create a finely-tuned sound field effortlessly.

- *Using the position selector (Position)*
- *Using balance adjustment (Fader)*
- *Using subwoofer output (Subwoofer1)*
- *Adjusting subwoofer settings (Subwoofer2)*
- *Adjusting low pass filter attenuation slope (Subwoofer3)*
- *Setting the high pass filter for front speakers (Front HPF, Front HPF FREQ.)*
- *Setting the high pass filter for rear speakers (Rear HPF, Rear HPF FREQ.)*
- *Auto TA and EQ (auto-time alignment and auto-equalizing)*
- *Recalling equalizer curves*
- *Adjusting equalizer curves*
- *Adjusting 16-band graphic equalizer (FREQ.)* 

Extra functions

These functions are helpful in adjusting the sound to suit your system or your personal preferences.

- *Using BBE sound (BBE)*
- *Using compression and BMX (COMP/BMX)*
- *Adjusting loudness (Loudness)*
- *Adjusting source levels (SLA)*
- *Using auditory user interface (AUI sound level)* 

Introduction of audio adjustments

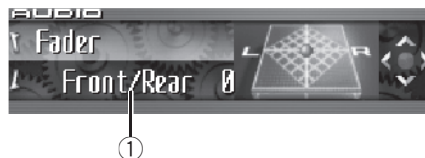

Important

When phone is selected as a source, no audio adjustments, except balance adjustment, are possible.

① Audio display

Shows the audio adjustment status.

1 Press MULTI-CONTROL to display the main menu.

FUNCTION, AUDIO and **ENTERTAINMENT** appear on the display.

2 Use MULTI-CONTROL to select AUDIO.

Turn to change the menu option; press to select.

The audio function name appears on the display.

3 Turn MULTI-CONTROL to select the audio function.

Turn **MULTI-CONTROL** clockwise or counterclockwise to switch between the audio functions in the following order:

Fader (balance adjustment)—**Position** (position selector)—**TA Mode** (time alignment setting)—**Time Alignment** (time alignment adjusting)—**Loudness** (loudness)—**Powerful** (graphic equalizer adjustment)—**FREQ.** (16-band graphic equalizer adjustment)—

Subwoofer1 (subwoofer on/off)—

Subwoofer2 (subwoofer cut-off frequency)—

Subwoofer3 (subwoofer slope)—**Front HPF** (front high pass filter slope)—

Front HPF FREQ. (front high pass filter cut-off frequency)—**Rear HPF** (rear high pass filter slope)—**Rear HPF FREQ.** (rear high pass filter cut-off frequency)—

BBE (BBE)—**COMP/BMX** (Compression and BMX)—**Auto EQ** (auto-equalizer on/off)—

SLA (source level adjustment)—**AUI sound level** (auditory user interface)

- When selecting **OFF** in **TA Mode**, you cannot switch to **Time Alignment**.

- You can select **Subwoofer2** and

Subwoofer3 only when subwoofer output is turned on in **Subwoofer1**.

- When tuner, television or AUX is selected as a source, you cannot select **COMP/BMX**.

- When selecting the FM tuner as the source, you cannot switch to **SLA**.

- To return to the display of each source, press **BAND**.



Note

If you do not operate the audio function within about 30 seconds, the display is automatically returned to the source display. 

Using the position selector

One way to assure a more natural sound is to clearly position the stereo image, putting you right in the center of the sound field. The position selector function lets you automatically adjust the speakers' output levels and inserts a delay time to match the number and position of occupied seats.

1 Use MULTI-CONTROL to select Position. **Position** appears in the display.

2 Push MULTI-CONTROL left, right, up or down to select a listening position.

Direction	Display	Position
Left	Front Left	Front seat left
Right	Front Right	Front seat right
Up	Front	Front seats
Down	All	All seats

- To cancel the selected listening position, push **MULTI-CONTROL** in the same direction again. 

Using balance adjustment

You can change the fader/balance setting so that it can provide you an ideal listening environment in all occupied seats.

1 Use MULTI-CONTROL to select Fader. **Fader** appears in the display.

- If the balance setting has been previously adjusted, **Balance** will be displayed.

2 Push MULTI-CONTROL up or down to adjust front/rear speaker balance.

Each time **MULTI-CONTROL** is pushed up or down, the front/rear speaker balance moves towards the front or rear.

Audio Adjustments

Front 25 to **Rear 25** is displayed as the front/rear speaker balance moves from front to rear.

- **Front/Rear 0** is the proper setting when only two speakers are used.

3 Push MULTI-CONTROL left or right to adjust left/right speaker balance.

Each time **MULTI-CONTROL** is pushed left or right, the left/right speaker balance moves towards the left or right.

Left 25 to **Right 25** is displayed as the left/right speaker balance moves from left to right. 

Using the time alignment

The time alignment lets you adjust the distance between each speaker and the listening position.

1 Use MULTI-CONTROL to select TA Mode.

TA Mode appears in the display.

2 Push MULTI-CONTROL left or right to select the time alignment.

Each time **MULTI-CONTROL** is pushed left or right, time alignment is selected in the following order:

Initial (initial)—**Custom** (custom)—**Auto TA** (auto-time alignment)—**OFF** (off)

- **Initial** is the factory supplied time alignment.
- **Custom** is an adjusted time alignment that you can create for yourself.
- **Auto TA** is the time alignment created by auto TA and EQ. (Refer to *Auto TA and EQ (auto-time alignment and auto-equalizing)* on page 80.)
- **Please set Auto TA** appears. This indicates that you cannot select **Auto TA** if auto TA and EQ has not been carried out.

Adjusting the time alignment

You can adjust the distance between each speaker and the selected position.

- An adjusted time alignment is memorized in **Custom**.

1 Use MULTI-CONTROL to select TA Mode.

TA Mode appears in the display.

2 Press MULTI-CONTROL to select a unit of distance.

Each press of **MULTI-CONTROL** selects the unit of distance in the following order:

cm (centimeter)—**inch** (inch)

3 Use MULTI-CONTROL to select Time Alignment.

Time Alignment appears in the display.

- **Can't adjust TA. Set position FL/FR** appears when neither **Front Left** nor **Front Right** is selected in the position selector mode (**Position**).
- When selecting **OFF** in **TA Mode**, you cannot switch to **Time Alignment**.

4 Push MULTI-CONTROL left or right to select the speaker to be adjusted.

Each time **MULTI-CONTROL** is pushed left or right, the speaker is selected in the following order:

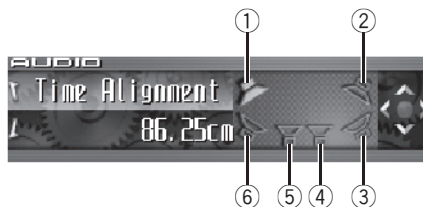

- ① Front speaker left
- ② Front speaker right
- ③ Rear speaker right
- ④ Subwoofer right
- ⑤ Subwoofer left
- ⑥ Rear speaker left

Front speaker left—Front speaker right—Rear speaker right—Rear speaker left—Subwoofer left—Subwoofer right

- You cannot select subwoofer left and subwoofer right when the subwoofer output is off.

5 Push MULTI-CONTROL up or down to adjust the distance between the selected speaker and the listening position.

Each time **MULTI-CONTROL** is pushed up or down, the distance increases or decreases.

400.00cm to **0.00cm** is displayed as the distance is increased or decreased, if you have selected centimeters (**cm**).

160.0inch to **0.0inch** is displayed as the distance is increased or decreased, if you have selected inches (**inch**).

- You can adjust the distance for the other speakers in the same way.

6 Press BAND to cancel the time alignment mode.

Using subwoofer output

This unit is equipped with a subwoofer output which can be turned on or off. When a subwoofer is connected to this unit, turn the subwoofer output on.

The subwoofer output phase can be switched between normal and reverse.

1 Use MULTI-CONTROL to select Subwoofer1.

Subwoofer1 appears in the display.

2 Press MULTI-CONTROL to turn subwoofer output on.

ON appears in the display. Subwoofer output is now on.

- To turn subwoofer output off, press **MULTI-CONTROL** again.

3 Push MULTI-CONTROL left or right to select stereo or monaural.

Push **MULTI-CONTROL** left to select monaural and **MONO** appears in the display. Push **MULTI-CONTROL** right to select stereo and **STEREO** appears in the display.

Adjusting subwoofer settings

When the subwoofer output is on, you can adjust the cut-off frequency and the output level of the subwoofer.

1 Use MULTI-CONTROL to select Subwoofer2.

Subwoofer2 appears in the display.

- When the subwoofer output is on, you can select **Subwoofer2**.

2 Push MULTI-CONTROL left or right to select cut-off frequency.

Each time **MULTI-CONTROL** is pushed left or right, cut-off frequencies are selected in the following order:

50—63—80—100—125—160—200 (Hz)

Only frequencies lower than those in the selected range are outputted from the subwoofer.

3 Push MULTI-CONTROL up or down to adjust the output level of the subwoofer.

Each time **MULTI-CONTROL** is pushed up or down, subwoofer level increases or decreases. **+6** to **-24** is displayed as the level is increased or decreased.

Adjusting low pass filter attenuation slope

When the subwoofer output is on, you can adjust the continuity of sound between speaker units.



Audio Adjustments

1 Use MULTI-CONTROL to select Subwoofer3.

Subwoofer3 appears in the display.

- When the subwoofer output is on, you can select **Subwoofer3**.

2 Push MULTI-CONTROL up or down to select the phase of subwoofer output.

Push **MULTI-CONTROL** up to select normal phase and  appears in the display. Push **MULTI-CONTROL** down to select reverse phase and  appears in the display.

3 Push MULTI-CONTROL left or right to select slope.

Each time **MULTI-CONTROL** is pushed left or right, slopes are selected in the following order:

-18—**-12**—**-6** (dB/oct.)

Note

When slope of subwoofer and high pass filter are **-12dB**, and same cut-off frequency, the phase is reversed 180 degrees at the cut-off frequency. In this case, reversing the phase assures improved sound continuity. 

Using the high pass filter

When you do not want low sounds from the subwoofer output frequency range to play from the front or rear speakers, turn on the HPF (high pass filter). Only frequencies higher than those in the selected range are outputted from the front or rear speakers.

Muting the speaker units (filters)

You can mute front and rear speaker units (filters) separately. When speaker units (filters) are muted, no sound is outputted from those speakers.

- If you mute the selected speaker unit (filter), **MUTE ON** is displayed and no adjustments are possible.
- Even if any speaker unit (filter) is muted, you can adjust the parameters for other speaker units (filters).

1 Use MULTI-CONTROL to select Front HPF (or Rear HPF).

Front HPF (or **Rear HPF**) appears in the display.

2 Push and hold MULTI-CONTROL down to mute the selected speaker unit (filter).

MUTE ON is displayed.

- To cancel the muting, push **MULTI-CONTROL** up.

Setting the high pass filter for front speakers

1 Use MULTI-CONTROL to select Front HPF.

Front HPF appears in the display.

2 Push MULTI-CONTROL left or right to select slope.

Each time **MULTI-CONTROL** is pushed left or right, slopes are selected in the following order:

-12—**-6**—**Pass (0)** (dB/oct.)

- If you set the slope to 0 dB/oct. (**Pass**), the audio signal bypasses the filter, so the filter does not have an effect.

3 Turn MULTI-CONTROL to select Front HPF FREQ.

Front HPF FREQ. appears in the display.

4 Push MULTI-CONTROL left or right to select cut-off frequency.

Each time **MULTI-CONTROL** is pushed left or right, cut-off frequencies are selected in the following order:

Audio Adjustments

50—63—80—100—125—160—200 (Hz)

Only frequencies higher than those in the selected range are output from the front speakers.

5 Push MULTI-CONTROL up or down to adjust the output level of the front speakers.

Each time **MULTI-CONTROL** is pushed up or down, the level of the front speakers increases or decreases. **0** to **-24** is displayed as the level is increased or decreased.

Setting the high pass filter for rear speakers

1 Use MULTI-CONTROL to select

Rear HPF.

Rear HPF appears in the display.

2 Push MULTI-CONTROL left or right to select slope.

Each time **MULTI-CONTROL** is pushed left or right, slopes are selected in the following order:

-12—-6—Pass (0) (dB/oct.)

- If you set the slope to 0 dB/oct. (**Pass**), the audio signal bypasses the filter, so the filter does not have an effect.

3 Turn MULTI-CONTROL to select

Rear HPF FREQ.

Rear HPF FREQ. appears in the display.

4 Push MULTI-CONTROL left or right to select cut-off frequency.

Each time **MULTI-CONTROL** is pushed left or right, cut-off frequencies are selected in the following order:

50—63—80—100—125—160—200 (Hz)

Only frequencies higher than those in the selected range are output from the rear speakers.

5 Push MULTI-CONTROL up or down to adjust the output level of the rear speakers.

Each time **MULTI-CONTROL** is pushed up or down, the level of the rear speakers increases or decreases. **0** to **-24** is displayed as the level is increased or decreased.

Using the auto-equalizer

The auto-equalizer is the equalizer curve created by auto TA and EQ (refer to *Auto TA and EQ (auto-time alignment and auto-equalizing)* on page 80).

You can turn the auto-equalizer on or off.

1 Use MULTI-CONTROL to select Auto EQ. Auto EQ appears in the display.

- **Please set Auto EQ** appears. This indicates that you cannot turn the auto-equalizer on if auto TA and EQ has not been carried out.

2 Press MULTI-CONTROL to turn the auto-equalizer on.

ON appears in the display.

- To turn auto-equalizer off, press **MULTI-CONTROL** again.

Using the equalizer

The equalizer lets you adjust the equalization to match car interior acoustic characteristics as desired.

Recalling equalizer curves

There are seven stored equalizer curves which you can easily recall at any time. Here is a list of the equalizer curves:

Audio Adjustments

Display	Equalizer curve
Powerful	Powerful
Natural	Natural
Vocal	Vocal
Flat	Flat
Custom1	Custom 1
Custom2	Custom 2
Super Bass	Super bass

- **Custom1** and **Custom2** are adjusted equalizer curves that you create. Adjustments can be made with a 16-band graphic equalizer.
- When **Flat** is selected no supplement or correction is made to the sound. This is useful to check the effect of the equalizer curves by switching alternatively between **Flat** and a set equalizer curve.
- **Press EQ to select the equalizer.**

Press **EQ** repeatedly to switch between the following equalizers:

Powerful—Natural—Vocal—Flat—Custom1—Custom2—Super Bass

Adjusting equalizer curves

The factory supplied equalizer curves, with the exception of **Flat**, can be adjusted to a fine degree (nuance control).

1 Use MULTI-CONTROL to select the graphic equalizer adjustment.

Powerful appears in the display.

- If the equalizer curve has been previously selected, the curve of that previously selected will be displayed instead of **Powerful**.

2 Push MULTI-CONTROL left or right to select an equalizer curve.

Each time **MULTI-CONTROL** is pushed left or right, equalizer curves are selected in the following order:

Powerful—Natural—Vocal—Flat—Custom1—Custom2—Super Bass

3 Push MULTI-CONTROL up or down to adjust the equalizer curve.

Each time **MULTI-CONTROL** is pushed up or down, the equalizer curve increases or decreases respectively.

+6 to **-6** is displayed as the equalizer curve is increased or decreased.

- The actual range of the adjustments are different depending on which equalizer curve is selected.
- The equalizer curve with all frequencies set to **0** cannot be adjusted.

Adjusting 16-band graphic equalizer

For **Custom1** and **Custom2** equalizer curves, you can adjust the level of each band.

- A separate **Custom1** curve can be created for each source. (The built-in CD player and the multi-CD player are set to the same equalizer adjustment setting automatically.) If you make adjustments when a curve other than **Custom2** is selected, the equalizer curve settings will be memorized in **Custom1**.
- A **Custom2** curve can be created common to all sources. If you make adjustments when the **Custom2** curve is selected, the **Custom2** curve will be updated.

1 Recall the equalizer curve you want to adjust.

See *Recalling equalizer curves* on the previous page.

Audio Adjustments

2 Use MULTI-CONTROL to select 16-band graphic equalizer adjustment.

FREQ. appears in the display.

3 Push MULTI-CONTROL left or right to select the equalizer band to adjust.

Each time **MULTI-CONTROL** is pushed left or right, equalizer bands are selected in the following order:

20—31.5—50—80—125—200—315—500—800—1.25k—2k—3.15k—5k—8k—12.5k—20k (Hz)

4 Push MULTI-CONTROL up or down to adjust the level of the equalizer band.

Each time **MULTI-CONTROL** is pushed up or down, the level of the equalization band increases or decreases.

+6 to -6 is displayed as the level is increased or decreased.

- You can then select another band and adjust the level.

5 Press BAND to cancel the 16-band graphic equalizer adjustment. 

Using BBE sound

With BBE, playback very close to the original sound can be obtained by correction with a combination of phase compensation and high-range boost for the delay of the high-frequency components and the amplitude deviation occurring during playback. This function makes it possible to reproduce the dynamic sound field as if you are listening to a live performance.

With BBE sound processing technology, you can adjust the level of BBE.

1 Use MULTI-CONTROL to select BBE.

BBE appears in the display.

2 Press MULTI-CONTROL to turn BBE on.

- To turn BBE off, press **MULTI-CONTROL** again.

3 Push MULTI-CONTROL up or down to adjust the level of BBE.

Each time **MULTI-CONTROL** is pushed up or down, the level of BBE increases or decreases. **+4 to -4** is displayed as the level is increased or decreased.



Note

Manufactured under license from BBE Sound, Inc. The mark BBE is a trademark of BBE Sound, Inc. 

Using compression and BMX

Using the COMP (compression) and BMX functions let you adjust the sound playback quality of this unit. Each of the functions has a two-step adjustment. The COMP function balances the output of louder and softer sounds at higher volumes. BMX controls sound reverberations to give playback a fuller sound. Listen to each of the effects as you select through them and use the one that best enhances the playback of the track or CD that you are listening to.

- When tuner, television or AUX is selected as a source, you cannot select **COMP/BMX**.

1 Use MULTI-CONTROL to select COMP/BMX.

COMP/BMX appears in the display.

2 Press MULTI-CONTROL to turn COMP/BMX on.

- To turn COMP/BMX off, press **MULTI-CONTROL** again.

Audio Adjustments

3 Push MULTI-CONTROL left or right to select the desired setting.

Each time **MULTI-CONTROL** is pushed left or right, settings are selected in the following order:

COMP 1—COMP 2—BMX 1—BMX 2 

Adjusting loudness

Loudness compensates for deficiencies in the low- and high-sound ranges at low volume.

1 Use MULTI-CONTROL to select Loudness.

Loudness appears in the display.

2 Press MULTI-CONTROL to turn loudness on.

ON appears in the display.

- To turn loudness off, press **MULTI-CONTROL** again. 

Adjusting source levels

SLA (source level adjustment) lets you adjust the volume level of each source to prevent radical changes in volume when switching between sources.

- Settings are based on the FM tuner volume level, which remains unchanged.

1 Compare the FM tuner volume level with the level of the source you wish to adjust.

2 Use MULTI-CONTROL to select SLA.

SLA appears in the display.

- When selecting the FM tuner as the source, you cannot switch to **SLA**.

3 Push MULTI-CONTROL up or down to adjust the source volume.

Each time **MULTI-CONTROL** is pushed up or down, source volume increases or decreases. **+4** to **-4** is displayed as the source volume is increased or decreased.



Notes

- The AM tuner volume level can also be adjusted with source level adjustments.
- The built-in CD player and the multi-CD player are set to the same source level adjustment volume automatically.
- External unit 1 and external unit 2 are set to the same source level adjustment volume automatically. 

Using auditory user interface

AUI (auditory user interface) lets you adjust the volume level of AUI sounds output when operating this unit. Depending on the operations, different AUI sounds are output.

- No AUI sounds are output when the sources are off.
- No AUI sounds are output when the level is set to 0.

1 Use MULTI-CONTROL to select AUI sound level.

AUI sound level appears in the display.

2 Push MULTI-CONTROL up or down to adjust AUI sound level.

Each time **MULTI-CONTROL** is pushed up or down, AUI sound level increases or decreases. **Level 0** to **Level 12** is displayed as AUI sound level is increased or decreased. 

Auto TA and EQ (auto-time alignment and auto-equalizing)

The auto-time alignment is automatically adjusted for the distance between each speaker and the listening position.

The auto-equalizer automatically measures the car interior acoustic characteristics, and then creates the auto-equalizer curve based on that information.



WARNING

To prevent accidents, never carry out auto TA and EQ while driving. When this function measures the car interior acoustic characteristics to create an auto-equalizer curve, a loud measurement tone (noise) may be outputted from the speakers.



CAUTION

- Carrying out auto TA and EQ under the following conditions may damage the speakers. Be sure to check the conditions thoroughly before carrying out auto TA and EQ.
 - When speakers are incorrectly connected. (e.g., When a rear speaker is connected to a subwoofer output.)
 - When a speaker is connected to a power amp delivering output higher than the speaker's maximum input power capability.
- If the microphone is placed in an unsuitable position the measurement tone may become loud and measurement may take a long time, resulting in a drain on battery power. Be sure to place the microphone in the specified location.

Before operating the auto TA and EQ function

- Carry out auto TA and EQ in as quiet a place as possible, with the car engine and air conditioning switched off. Also cut power to car phones or portable telephones in the car, or remove them from the car before carrying out auto TA and EQ. Sounds other than the measurement tone (surrounding sounds, engine sound, telephones ringing etc.) may prevent correct measurement of the car interior acoustic characteristics.
- Be sure to carry out auto TA and EQ using the supplied microphone. Using another microphone may prevent measurement, or result in incorrect measurement of the car interior acoustic characteristics.
- When front speaker is not connected, auto TA and EQ cannot be carried out.
- When muting the front speaker units, auto TA and EQ cannot be carried out. (Refer to page 75.)
- When this unit is connected to a power amp with input level control, auto TA and EQ may not be possible if you lower power amp input level. Set the power amp's input level to the standard position.
- When this unit is connected to a power amp with an LPF, turn off the LPF on the power amp before carrying out auto TA and EQ. In addition, the cut-off frequency for built-in LPF of an active subwoofer should be set to the highest frequency.
- The time alignment value calculated by auto TA and EQ may differ from the actual distance in the following circumstances. However, the distance has been calculated by computer to be the optimum delay to give accurate results for the circumstances, so please continue to use this value.
 - When the reflected sound within a vehicle is strong and delays occur.

Audio Adjustments

- When delays occur for low sounds due to the influence of the LPF on active subwoofers or external amps.
- Auto TA and EQ changes the audio settings as below:
 - The fader/balance settings return to the center position. (Refer to page 72.)
 - The graphic equalizer curve switches to **Flat**. (Refer to page 76.)
 - When a subwoofer is connected to this unit, it will be adjusted automatically to both subwoofer output and high pass filter setting for rear speaker.
- If you carry out auto TA and EQ when a previous setting of this already exists, the setting will be replaced.

Carrying out auto TA and EQ

! CAUTION

Never use the microphone for hands-free phoning to operate the auto TA and EQ. Using the microphone unfit for the auto TA and EQ may damage the speaker. Be sure to connect the AUTO TA&EQ microphone into the microphone input jack.

1 Stop the car in a place that is as quiet as possible, close all doors, windows and the sun roof, and then turn the engine off. If the engine is left running, engine noise may prevent correct auto TA and EQ.

2 Fix the supplied microphone in the center of the headrest of the driver's seat, facing forward, using the belt (sold separately).

The auto TA and EQ may differ depending on where you place the microphone. If desired, place the microphone on the front passenger seat to carry out auto TA and EQ.

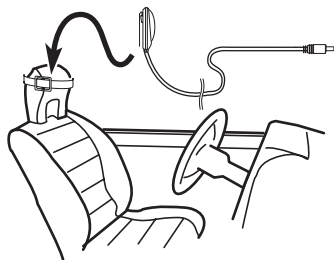

3 Turn the ignition switch to ON or ACC.

If the car's air conditioner or heater is turned on, turn it off. Noise from the fan in the air conditioner or heater may prevent correct auto TA and EQ.

- Press **SOURCE** to turn the source on if this unit is turned off.

4 Select the position for the seat on which the microphone is placed.

Refer to *Using the position selector* on page 72.

- If no position is selected before you start auto TA and EQ, **Front Left** is selected automatically.

5 Press SOURCE and hold until the unit turns off.

If anything is connected to the microphone input jack, disconnect it.

6 Press and hold EQ to enter the auto TA and EQ measurement mode.

7 Plug the microphone into the microphone input jack on this unit.

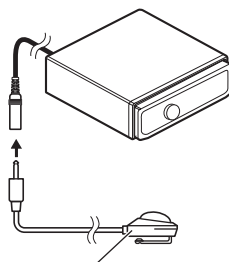

AUTO TA&EQ microphone

8 Press MULTI-CONTROL to start the auto TA and EQ.**9 Get out of the car and close the door within 10 seconds when the 10-second count-down starts.**

The measurement tone (noise) is outputted from the speakers, and auto TA and EQ begins.

- When all speakers are connected, auto TA and EQ is completed in about six minutes.
- To stop auto TA and EQ, press **MULTI-CONTROL** again.
- To cancel auto TA and EQ part way through, press **BAND**.

10 When auto TA and EQ is completed, Setup complete is displayed.

When correct measurement of car interior acoustic characteristics is not possible, an error message is displayed. (Refer to *Understanding auto TA and EQ error messages* on page 93.)

11 Press BAND to cancel the auto TA and EQ mode.**12 Store the microphone carefully in the glove compartment.**

Store the microphone carefully in the glove compartment or any other safe place. If the microphone is subjected to direct sunlight for an extended period, high temperatures may cause distortion, color change or malfunction. 

Initial Settings

Adjusting initial settings

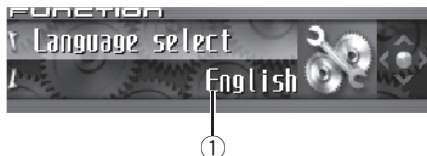

Using the initial settings, you can customize various system settings to achieve optimal performance from this unit.

① Function display

Shows the function status.

1 Press SOURCE and hold until the unit turns off.

2 Press MULTI-CONTROL and hold until Language select appears in the display.

3 Turn MULTI-CONTROL to select one of the initial settings.

Turn **MULTI-CONTROL** clockwise or counter-clockwise to switch between the functions in the following order:

Language select (language selection)—

Calendar (calendar)—**Clock** (clock)—

FM tuning step (FM tuning step)—

AM tuning step (AM tuning step)—

Warning tone (warning tone)—

Face auto open (face auto open)—**AUX1**

(auxiliary input 1)—**AUX2** (auxiliary input 2)—

Dimmer (dimmer)—**Brightness** (brightness)

—**Digital ATT** (digital attenuator)—**Mute**

(sound muting/attenuation)—**Demonstration**

(feature demo)—**Reverse mode** (reverse

mode)—**Ever-scroll** (ever scroll)—**Calibration**

(RPM calibration)—**BT AUDIO** (Bluetooth

audio)—**Pin code input** (pin code input)—

Phone reset (phone reset)

Use the following instructions to operate each particular setting.

- To cancel initial settings, press **BAND**. 

Selecting the display language

For your convenience, this unit equips multiple language display. You can select the language best suited to your first language.

1 Use MULTI-CONTROL to select Language select.

Language select appears in the display.

2 Press MULTI-CONTROL to select the language.

Each press of **MULTI-CONTROL** selects languages in the following order:

English—Español—Português 

Setting the date

The calendar display adjusted in this mode appears when the telephone source is selected or sources and the feature demo are off.

1 Use MULTI-CONTROL to select Calendar.

Calendar appears in the display.

2 Push MULTI-CONTROL left or right to select the segment of the calendar display you wish to set.

Pushing **MULTI-CONTROL** left or right will select one segment of the calendar display:

Day—Month—Year

As you select segments of the calendar display the segment selected will blink.



3 Push **MULTI-CONTROL** up or down to set the date.

Pushing **MULTI-CONTROL** up will increase the selected day, month or year. Pushing **MULTI-CONTROL** down will decrease the selected day, month or year. 

Setting the clock

Use these instructions to set the clock.

1 Use **MULTI-CONTROL** to select **Clock**. **Clock** appears in the display.

2 Push **MULTI-CONTROL** left or right to select the segment of the clock display you wish to set.

Pushing **MULTI-CONTROL** left or right will select one segment of the clock display: Hour—Minute

As you select segments of the clock display the segment selected will blink.



3 Push **MULTI-CONTROL** up or down to set the clock.

Pushing **MULTI-CONTROL** up will increase the selected hour or minute. Pushing **MULTI-CONTROL** down will decrease the selected hour or minute.



Notes

- You can match the clock to a time signal by pressing **MULTI-CONTROL**.
 - If the minute is **00** to **29**, the minutes are rounded down. (e.g., **10:18** becomes **10:00**.)
 - If the minute is **30** to **59**, the minutes are rounded up. (e.g., **10:36** becomes **11:00**.)

- Even when the sources are off, the clock display appears on the display. Pressing **CLOCK** when the sources and feature demo are off, turns the clock display on or off. 

Setting the FM tuning step

The FM tuning step employed by seek tuning can be switched between 100 kHz, the preset step, and 50 kHz.

1 Use **MULTI-CONTROL** to select **FM tuning step**. **FM tuning step** appears in the display.

FM tuning step appears in the display.

2 Press **MULTI-CONTROL** to select the **FM tuning step**.

Pressing **MULTI-CONTROL** repeatedly will switch the FM tuning step between 50 kHz and 100 kHz. The selected FM tuning step will appear in the display.



Note

If seek tuning is performed in 50 kHz steps, stations may be tuned in imprecisely. Tune in the stations with manual tuning or use seek tuning again. 

Setting the AM tuning step

The AM tuning step can be switched between 9 kHz, the preset step, and 10 kHz. When using the tuner in North, Central or South America, reset the tuning step from 9 kHz (531 kHz to 1 602 kHz allowable) to 10 kHz (530 kHz to 1 640 kHz allowable).

1 Use **MULTI-CONTROL** to select **AM tuning step**. **AM tuning step** appears in the display.

AM tuning step appears in the display.

Initial Settings

2 Press **MULTI-CONTROL** to select the **AM tuning step**.

Pressing **MULTI-CONTROL** repeatedly will switch the AM tuning step between 9 kHz and 10 kHz. The selected AM tuning step will appear in the display. 

Switching the warning tone

If the front panel is not detached from the head unit within four seconds of turning off the ignition, a warning tone will sound. You can turn off the warning tone.

1 Use **MULTI-CONTROL** to select **Warning tone**.

Warning tone appears in the display.

2 Press **MULTI-CONTROL** to turn warning tone on.

ON appears in the display.

- To turn warning tone off, press **MULTI-CONTROL** again. 

Switching the face auto open

For theft protection, the front panel opens automatically and easily detaches. Face auto open is on as a default.

1 Use **MULTI-CONTROL** to select **Face auto open**.

Face auto open appears in the display.

2 Press **MULTI-CONTROL** to turn the face auto open on.

ON appears in the display.

- To turn the face auto open off, press **MULTI-CONTROL** again. 

Switching the auxiliary setting

Auxiliary equipments connected to this unit can be activated individually. Set each AUX source to ON when using. About connecting or using auxiliary equipments, refer to *Using the AUX source* on page 89.

1 Use **MULTI-CONTROL** to select **AUX1/AUX2**.

AUX1/AUX2 appears in the display.

2 Press **MULTI-CONTROL** to turn **AUX1/AUX2** on.

ON appears in the display.

- To turn AUX off, press **MULTI-CONTROL** again. 

Switching the dimmer setting

To prevent the display from being too bright at night, the display is automatically dimmed when the car's headlights are turned on. You can turn the dimmer on or off.

1 Use **MULTI-CONTROL** to select **Dimmer**.

Dimmer appears in the display.

2 Press **MULTI-CONTROL** to turn dimmer on.

ON appears in the display.

- To turn dimmer off, press **MULTI-CONTROL** again. 

Adjusting the brightness

You can adjust the display brightness. Initially this mode is set to **24**.

1 Use **MULTI-CONTROL** to select **Brightness**.

Brightness appears in the display.

2 Push MULTI-CONTROL left or right to adjust the brightness level.

Each time **MULTI-CONTROL** is pushed left or right, brightness level increases or decreases. **0** to **31** is displayed as the level is increased or decreased.

- When dimmer is functioning, the brightness level can be adjusted **0** to **21**. 

Correcting distorted sound

When listening to a CD or other sound on which the recording level is high, setting the equalizer curve level to high may result in distortion. You can switch the digital attenuator to low to reduce distortion.

- Sound quality is better at the high setting so this setting is usually used.

1 Use MULTI-CONTROL to select Digital ATT.

Digital ATT appears in the display.

2 Press MULTI-CONTROL to select the digital attenuator level.

Pressing **MULTI-CONTROL** repeatedly will switch between **High** (high) and **Low** (low) and that status will be displayed. 

Switching the sound muting/attenuation

Sound from this system is muted or attenuated automatically when the signal from the equipment with mute function is received.

- The sound is muted or attenuated, **MUTE** or **ATT** are displayed and no audio adjustment is possible.
- Sound from this system returns to normal when the muting or attenuation is canceled.

1 Use MULTI-CONTROL to select Mute.

Mute appears in the display.

2 Press MULTI-CONTROL to select the desired setting.

Press **MULTI-CONTROL** repeatedly to switch between the following settings:

- **TEL mute** – Muting
- **10dB ATT** – Attenuation
- **20dB ATT** – Attenuation (**20dB ATT** has a stronger effect than **10dB ATT**) 

Switching the feature demo

The feature demo automatically starts when power to this unit is turned off while the ignition switch is set to ACC or ON.

1 Use MULTI-CONTROL to select Demonstration.

Demonstration appears in the display.

2 Press MULTI-CONTROL to turn the feature demo on.

ON appears in the display.

- To turn the feature demo off, press **MULTI-CONTROL** again.



Notes

- Remember that if the feature demo continues operating when the car engine is turned off, it may drain battery power.
- You can also turn on or off feature demo by pressing **DISPLAY** while this unit is turned off. For more details, see *Feature demo mode* on page 10. 

Initial Settings

Switching the reverse mode

If you do not perform an operation within about 30 seconds, screen indications start to reverse, and then continue reversing every 10 seconds.

1 Use MULTI-CONTROL to select Reverse mode.

Reverse mode appears in the display.

2 Press MULTI-CONTROL to turn the reverse mode on.

ON appears in the display.

- To turn the reverse mode off, press **MULTI-CONTROL** again.



Note

You can also turn on or off reverse mode by pressing **BAND** while this unit is turned off. For more details, see *Reverse mode* on page 9. 

Switching the Ever Scroll

When Ever Scroll is set to ON, CD text information scrolls continuously in the display. Set to OFF if you prefer the information to scroll just once.

1 Use MULTI-CONTROL to select Ever-scroll.

Ever-scroll appears in the display.

2 Press MULTI-CONTROL to turn the Ever Scroll on.

ON appears in the display.

- To turn the Ever Scroll off, press **MULTI-CONTROL** again. 

Calibrating the RPMs

Follow the instructions below to measure the RPM of your vehicle and records them. By doing this, the tachometer of this unit can work properly.

- Tachometer of this unit cannot work if you do not perform the RPM calibration.
- In some vehicles, the tachometer may not work properly even if you performed the RPM calibration.

1 Park your vehicle in a safe place and be sure to apply the parking brake.

2 Use MULTI-CONTROL to select Calibration.

Calibration appears in the display.

3 Keep RPMs of the engine at 4 000 rpm and press MULTI-CONTROL.

To measure the RPM of your vehicle properly, keep RPMs of the engine at 4 000 rpm for a few seconds.

When the RPM calibration is completed, **Completed** is displayed.

- Some vehicles have a rev limiter that kicks in early (e.g., 3 000 rpm) while parking. In this case, perform RPM measurement at 2 000 rpm.
- To switch between **4000 rpm** and **2000 rpm**, push **MULTI-CONTROL** left or right. 

Activating the BT Audio source

You need to activate the **BT Audio** source in order to use a Bluetooth audio player.

1 Use MULTI-CONTROL to select BT AUDIO.

BT AUDIO appears in the display.

Initial Settings

2 Press **MULTI-CONTROL** to turn the **BT Audio source on**.

ON appears in the display.

- To turn the **BT Audio** source off, press **MULTI-CONTROL** again. 

Entering PIN code for Bluetooth wireless connection

To connect your cellular phone to this unit via Bluetooth wireless technology, you need to enter PIN code on your phone to verify the connection. The default code is **0000**, but you can change this in this function.

- With some Bluetooth audio players, you may be required to enter to this unit in advance PIN code of your Bluetooth audio player, in order to set this unit ready for a connection from your Bluetooth audio player.

1 Use **MULTI-CONTROL** to select **Pin code input**.

Pin code input appears in the display.

2 Push **MULTI-CONTROL** up or down to select a number.

Pushing **MULTI-CONTROL** up or down changes the number.

3 Push **MULTI-CONTROL** right to move the cursor to the next position.

When the number you want is displayed, push **MULTI-CONTROL** right to move the cursor to the next position and then select the next number. Push **MULTI-CONTROL** left to move backwards in the display.

4 After inputting PIN code (up to 16 digits), press **MULTI-CONTROL**.

PIN code you entered is now standby to be stored in memory.

When you press **MULTI-CONTROL** again on the same display, the PIN code you entered is stored in this unit.

- Pushing **MULTI-CONTROL** right in the confirmation display returns you to the PIN code input display, and you can change the PIN code. 

Resetting the Bluetooth wireless technology module

Should you need to, you can reset the built-in Bluetooth wireless technology module. This will also clear all memories set in the telephone source, including Phone Book entries, number presets, registration assignments and the Call History.

For instruction on this operation, refer to *Clearing all memory* on page 8. 

Other Functions

Turning the clock display on or off

You can turn the clock display on or off.

- **Press CLOCK to turn the clock display on or off.**

Each press of **CLOCK** turns the clock display on or off.



Note

Even when the sources are off, the clock display appears on the display. Pressing **CLOCK** when the sources and feature demo are off, turns the clock display on or off. 

Using the AUX source

This unit can control up to two auxiliary equipments such as VCR or portable devices (sold separately). When connected, auxiliary equipments are automatically read in as AUX sources and assigned to **AUX1** or **AUX2**. The relationship between **AUX1** and **AUX2** sources is explained below.

About AUX1 and AUX2

You have two methods to connect auxiliary equipments to this unit.

AUX1 source:

When connecting auxiliary equipment using a stereo mini plug cable

- **Insert the stereo mini plug into the AUX input jack on this unit.**

For more details, refer to the installation manual.

The allocation of this auxiliary equipment is automatically set to **AUX1**.

AUX2 source:

When connecting auxiliary equipment using an IP-BUS-RCA Interconnector (sold separately)

- **Use an IP-BUS-RCA Interconnector such as the CD-RB20/CD-RB10 (sold separately) to connect this unit to auxiliary equipment featuring RCA output.**

For more details, refer to the IP-BUS-RCA Interconnector owner's manual.

The allocation of this auxiliary equipment is automatically set to **AUX2**.

- You can only make this type of connection if the auxiliary equipment has RCA outputs.

Selecting AUX as the source

- **Press SOURCE to select AUX (AUX1 or AUX2) as the source.**

Press **SOURCE** until **AUX** appears in the display.

- If the auxiliary setting is not turned on, **AUX** cannot be selected. For more details, see *Switching the auxiliary setting* on page 85.

Setting the AUX title

The title displayed for each **AUX1** or **AUX2** source can be changed.

- 1 After you have selected AUX as the source, use MULTI-CONTROL and select FUNCTION to display Title Input.**

- 2 Press DISPLAY to select the desired character type.**

Press **DISPLAY** repeatedly to switch between the following character types:

Alphabet (upper case), numbers and symbols
 —Alphabet (lower case)—European letters, such as those with accents (e.g. **á, à, ä, ç**)—
 Numbers and symbols

3 Push MULTI-CONTROL up or down to select a letter of the alphabet.

Each time **MULTI-CONTROL** is pushed up, alphabet, numbers or symbols are displayed in ascending order (**A B C ...**). Each time **MULTI-CONTROL** is pushed down, letters are displayed in descending order.



4 Push MULTI-CONTROL right to move the cursor to the next character position.

When the letter you want is displayed, push **MULTI-CONTROL** right to move the cursor to the next position and then select the next letter. Push **MULTI-CONTROL** left to move backwards in the display.

5 Move the cursor to the last position by pushing MULTI-CONTROL right after entering the title.

When you push **MULTI-CONTROL** right one more time, the entered title is stored in memory.

6 Press BAND to return to the playback display.

Using different entertainment displays



You can change the entertainment display to be displayed on all sources.

① Entertainment display name

Shows name of the currently selected entertainment display.

② Background display name

Shows name of the currently selected background display.

③ Source icon

Shows which source has been selected.

- Jacket art of current folder is displayed when playing an MP3/WMA/AAC/WAV disc.

Setting the entertainment display

You can change the entertainment display and text color.

- When you select **Vehicle Dynamics 1**, **Vehicle Dynamics 2** or **Vehicle Dynamics 3**, perform the RPM calibration. Refer to *Calibrating the RPMs* on page 87.

1 Press MULTI-CONTROL to display the main menu.

FUNCTION, **AUDIO** and **ENTERTAINMENT** appear on the display.

Other Functions

2 Use MULTI-CONTROL to select ENTERTAINMENT.

Turn to change the menu option; press to select.

3 Turn MULTI-CONTROL to select a desired entertainment display.

Turn **MULTI-CONTROL** clockwise or counter-clockwise to switch between the displays in the following order:

Standard (standard)—**Visualizer1** (visualizer 1)—**Visualizer2** (visualizer 2)—**Visualizer3** (visualizer 3)—**Visualizer4** (visualizer 4)—**Visualizer5** (visualizer 5)—**VisualizerRDM** (random visualizer)—**LevelMeter** (level meter)—**Spectrum Analyzer** (spectrum analyzer)—**Vehicle Dynamics 1** (vehicle dynamics processor 1)—**Vehicle Dynamics 2** (vehicle dynamics processor 2)—**Vehicle Dynamics 3** (vehicle dynamics processor 3)—**Movie** (movie screen)—**Clock** (entertainment clock)—**OFF** (entertainment display off)

- You can also switch between the entertainment display by pressing **ENTERTAINMENT** on the remote control.
- When **Standard** is selected, source icon can be turned on or off by pressing **DISPLAY**.

4 Push MULTI-CONTROL up or down to select a desired text color.

Each time **MULTI-CONTROL** is pushed up or down, the text color changes. You can select the text color from among 11 colors.

- When **Vehicle Dynamics 1**, **Vehicle Dynamics 2** or **Vehicle Dynamics 3** is selected, you can choose the color of gauge appearance from among five color combinations.
- Texts are not displayed on **Movie** and **OFF** setting.

5 Press MULTI-CONTROL to determine the entertainment display and text color setting.

The choices you made on the color and the entertainment display are stored in memory and the display reverts.

Setting the background display

Some entertainment displays allow you to change the backgrounds. Try different backgrounds and colors (if available) until you find the desirable background display setting for the selected entertainment display.

1 Select an entertainment display whose background can be changed.

If the entertainment display you selected is available for the background setting, ◀ and ▶ are displayed on the left and right side of **FRONT**. Refer to *Setting the entertainment display* on the previous page.

2 Push MULTI-CONTROL right to switch to the background display selection mode.

3 Turn MULTI-CONTROL to select a desired background.

Turn **MULTI-CONTROL** clockwise or counter-clockwise to switch between the displays in the following order:

BGV1 (background visual 1)—**BGV2** (background visual 2)—**BGV3** (background visual 3)—**BGV4** (background visual 4)—**BGV5** (background visual 5)—**BGP1** (background picture 1)—**BGP2** (background picture 2)—**BGP3** (background picture 3)—**BGP4** (background picture 4)—**BGP5** (background picture 5)—**BGP6** (background picture 6)—**BGP7** (background picture 7)—**BGP8** (background picture 8)—**Slideshow** (slideshow)—**Texture1** (texture 1)—**Texture2** (texture 2)—**Texture3** (texture 3)—**Texture4** (texture 4)—**OFF** (background display off)

- You cannot use **ENTERTAINMENT** on the remote control to switch between the background display.

4 When BGV1, BGV2 or Texture3 is selected, push **MULTI-CONTROL** up or down to select a desired color for the background.

Each time **MULTI-CONTROL** is pushed up or down, the background color changes. You can select the background color from among 11 colors (including rainbow mode).

- When the rainbow mode is selected, the background color continuously changes through all the colors.

5 Press **MULTI-CONTROL** to determine the background display setting.

The choices you made on the color and the background display are stored in memory and the display reverts. 

Rewriting the entertainment displays and the icons for telephone functions

You can rewrite the entertainment displays and the icons for telephone functions. Please create or download the data using your Computer, and record it on CD-R. For details, please visit the following site:

<http://www.pioneer.co.jp/car/pclink4/index-e.html>

Important

Once the rewriting process has started, do not remove the front panel or turn the ignition off, until it is completed.

1 Press **SOURCE** and hold until the unit turns off.

2 Press and hold **EQ** and **LIST** until the unit goes into download mode.

Front panel is opened automatically and then **Download** and **Insert disc** is displayed.

- If a disc is loaded in the unit, it is ejected automatically.
- When the front panel is open, does not go into download mode even if you press and hold **EQ** and **LIST**.

3 Insert the disc containing the rewritten data into the CD loading slot.

Download Ready appears in the display, and then data rewriting will start automatically.

Now loading is displayed during rewriting.

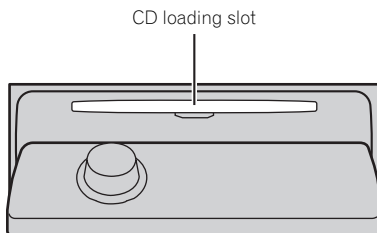

4 After **Finished** is displayed, press **EJECT** to eject the disc.

Download mode is exited and unit turns off.

Notes

- Do not insert anything other than a CD into the CD loading slot.
- It can take several minutes to complete this operation.
- During download mode, buttons other than **EJECT** are inactive.
- To cancel download mode, press **EJECT**.
- If an error message such as **CD ERROR** is displayed, refer to *Understanding error message on rewriting the entertainment displays* on page 94. 

Additional Information

Understanding built-in CD player error messages

When you contact your dealer or your nearest Pioneer Service Center, be sure to record the error message.

Message	Cause	Action
ERROR-11, 12, 17, 30	Dirty disc	Clean disc.
ERROR-11, 12, 17, 30	Scratched disc	Replace disc.
ERROR-10, 11, 12, 15, 17, 30, A0	Electrical or mechanical	Turn the ignition ON and OFF, or switch to a different source, then back to the CD player.
ERROR-15	The inserted disc does not contain any data	Replace disc.
ERROR-23	The CD format cannot be played back	Replace disc.
NO AUDIO	The inserted disc does not contain any files that can be played back	Replace disc.
Track Skipped	The inserted disc contains WMA files that are protected by DRM	Replace disc.
PROTECT	All the files on the inserted disc are secured by DRM	Replace disc.



pears, refer to the table below to see what the problem is and the suggested method of correcting the problem. After checking, try again.

Message	Cause	Action
Check MIC type	Microphone is connected to microphone input.	Disconnect the microphone.
MIC ERROR	Microphone is not connected.	Plug the supplied microphone securely into the jack.
Front Speaker ERROR, Front left Speaker ERROR, Front right Speaker ERROR, Rear left Speaker ERROR, Rear right Speaker ERROR, Subwoofer ERROR, Subwoofer Lch ERROR, Subwoofer Rch ERROR	The microphone cannot pick up the measuring tone of a speaker.	<ul style="list-style-type: none"> • Confirm that the speakers are connected correctly. • Cancel muting the front speaker units. • Correct the input level setting of the power amp connected to the speakers. • Set the microphone correctly.
Noise ERROR	The surrounding noise level is too high.	<ul style="list-style-type: none"> • Stop your car in a place that is as quiet as possible, and switch off the engine, air conditioner or heater. • Set the microphone correctly.



Understanding auto TA and EQ error messages

When correct measurement of car interior acoustic characteristics is not possible using the auto TA and EQ, an error message may appear on the display. If an error message ap-

Additional Information

Understanding error message on rewriting the entertainment displays

When you contact your dealer or your nearest Pioneer Service Center, be sure to record the error message.

Message	Cause	Action
CD ERROR	CD player error	Press EJECT and check the disc.
CD ERROR A0	Electrical error	Turn the ignition ON and OFF.
Disc ERROR	The disc does not contain the necessary data	Press EJECT and replace the disc.
Download ERROR, Transmit ERROR	Writing error	Press EJECT and retry the rewriting.
FILE ERROR	File error	Rewrite the file.



CD player and care

- Use only CDs that have either of the two Compact Disc Digital Audio marks as shown below.



- Use only normal, round CDs. If you insert irregular, non-round, shaped CDs they may jam in the CD player or not play properly.

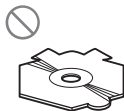

- Check all CDs for cracks, scratches or warping before playing. CDs that have cracks, scratches or are warped may not play properly. Do not use such discs.
- Avoid touching the recorded (non-printed) surface when handling the disc.
- Store discs in their cases when not in use.
- Keep discs out of direct sunlight and do not expose the discs to high temperatures.
- Do not attach labels, write on or apply chemicals to the surface of the discs.
- To clean a CD, wipe the disc with a soft cloth outward from the center.



- If the heater is used in cold weather, moisture may form on components inside the CD player. Condensation may cause the CD player to malfunction. If you think that condensation is a problem turn off the CD player for an hour or so to allow it to dry out and wipe any damp discs with a soft cloth to remove the moisture.
- Road shocks may interrupt CD playback. ■

CD-R/CD-RW discs

- When CD-R/CD-RW discs are used, playback is possible only for discs which have been finalized.
- It may not be possible to play back CD-R/CD-RW discs recorded on a music CD recorder or a personal computer because of disc characteristics, scratches or dirt on the disc, or dirt, condensation, etc., on the lens of this unit.

Additional Information

- Playback of discs recorded on a personal computer may not be possible, depending on the application settings and the environment. Please record with the correct format. (For details, contact the manufacturer of the application.)
- Playback of CD-R/CD-RW discs may become impossible in case of direct exposure to sunlight, high temperatures, or the storage conditions in the vehicle.
- Titles and other text information recorded on a CD-R/CD-RW disc may not be displayed by this unit (in the case of audio data (CD-DA)).
- Read the precautions with CD-R/CD-RW discs before using them. 

Dual Discs

- Dual Discs are two-sided discs that have a recordable CD for audio on one side and a recordable DVD for video on the other.
- Since the CD side of Dual Discs is not physically compatible with the general CD standard, it may not be possible to play the CD side with this unit.
- Frequent loading and ejecting of a Dual Disc may result in scratches on the disc. Serious scratches can lead to playback problems on this unit. In some cases, a Dual Disc may become stuck in the disc loading slot and will not eject. To prevent this, we recommend you refrain from using Dual Disc with this unit.
- Please refer to the information from the disc manufacturer for more detailed information about Dual Discs. 

MP3, WMA, AAC and WAV files

- MP3 is short for MPEG Audio Layer 3 and refers to an audio compression technology standard.
- WMA is short for Windows Media™ Audio and refers to an audio compression technology that is developed by Microsoft Corporation. WMA data can be encoded by using Windows Media Player version 7 or later.
- AAC is short for Advanced Audio Coding and refers to an audio compression technology standard.
- WAV is short for waveform. It is a standard audio file format for Windows®.
- This unit may not operate correctly depending on the application used to encode WMA files.
- Depending on the version of Windows Media Player used to encode WMA files, album names and other text information may not be correctly displayed.
- There may be a slight delay when starting playback of WMA/AAC files encoded with image data.
- This unit allows playback of MP3/WMA/AAC/WAV files on CD-ROM, CD-R and CD-RW discs. Disc recordings compatible with level 1 and level 2 of ISO9660 and with the Romeo and Joliet file system can be played back.
- It is possible to play back multi-session compatible recorded discs.
- MP3/WMA/AAC/WAV files are not compatible with packet write data transfer.
- The maximum number of characters which can be displayed for a file name, including the extension (.mp3, .wma, .m4a or .wav), is 64, from the first character.
- The maximum number of characters which can be displayed for a folder name is 64.
- In case of files recorded according to the Romeo file system, only the first 64 characters can be displayed.

Additional Information

- When playing discs with MP3/WMA/AAC/WAV files and audio data (CD-DA) such as CD-EXTRA and MIXED-MODE CDs, both types can be played only by switching mode between MP3/WMA/AAC/WAV and CD-DA.
- The folder selection sequence for playback and other operations becomes the writing sequence used by the writing software. For this reason, the expected sequence at the time of playback may not coincide with the actual playback sequence. However, there also is some writing software which permits setting of the playback order.
- Some audio CDs contain tracks that merge into one another without a pause. When these discs are converted to MP3/WMA/AAC/WAV files and burned to a CD-R/CD-RW/CD-ROM, the files will be played back on this player with a short pause between each one, regardless of the length of the pause between tracks on the original audio CD.
- The emphasis function is valid only when MP3 files of 32, 44.1 and 48 kHz frequencies are played back. (16, 22.05, 24, 32, 44.1, 48 kHz sampling frequencies can be played back.)
- There is no m3u playlist compatibility.
- There is no compatibility with the MP3i (MP3 interactive) or mp3 PRO formats.
- The sound quality of MP3 files generally becomes better with an increased bit rate. This unit can play recordings with bit rates from 8 kbps to 320 kbps, but in order to be able to enjoy sound of a certain quality, we recommend using only discs recorded with a bit rate of at least 128 kbps.

Important

- When naming an MP3/WMA/AAC/WAV file, add the corresponding filename extension (.mp3, .wma, .m4a or .wav).
- This unit plays back files with the filename extension (.mp3, .wma, m4a or .wav) as an MP3/WMA/AAC/WAV file. To prevent noise and malfunctions, do not use these extensions for files other than MP3/WMA/AAC/WAV files.

MP3 additional information

- Files are compatible with the ID3 Tag Ver. 1.0, 1.1, 2.2, 2.3 and 2.4 formats for display of album (disc title), track (track title), artist (track artist) and comments. Ver. 2.x of ID3 Tag is given priority when both Ver. 1.x and Ver. 2.x exist.

WMA additional information

- This unit plays back WMA files encoded by Windows Media Player version 7, 7.1, 8, 9 and 10.
- You can only play back WMA files in the frequencies 32, 44.1 and 48 kHz.
- The sound quality of WMA files generally becomes better with an increased bit rate. This unit can play recordings with bit rates from 48 kbps to 320 kbps (CBR) or from 48 kbps to 384 kbps (VBR), but in order to be able to enjoy sound of a certain quality, we recommend using discs recorded with a higher bit rate.
- This unit doesn't support the following formats.
 - Windows Media Audio 9 Professional (5.1ch)
 - Windows Media Audio 9 Lossless
 - Windows Media Audio 9 Voice

AAC additional information

- This unit plays back AAC files encoded by iTunes® version 4.8 and earlier.

Additional Information

- This unit plays back AAC files in the sampling frequencies 11.025, 16, 22.05, 24, 32, 44.1 and 48 kHz.
- The sound quality of AAC files generally becomes better with an increased transmission rate. This unit can play recordings with transmission rates from 16 kbps to 320 kbps, but in order to be able to enjoy sound of a certain quality, we recommend using discs recorded with a higher transmission rate.
- This unit doesn't support the following formats.
 - Apple Lossless

WAV additional information

- This unit plays back WAV files encoded in Linear PCM (LPCM) format or MS ADPCM format.
- You can only play back WAV files in the frequencies 16, 22.05, 24, 32, 44.1 and 48 kHz (LPCM), or 22.05 and 44.1 kHz (MS ADPCM). The sampling frequency shown in the display may be rounded.
- The sound quality of WAV files generally becomes better with a larger number of quantization bits. This unit can play recordings with 8 and 16 (LPCM) or 4 (MS ADPCM) quantization bits, but in order to be able to enjoy sound of a certain quality, we recommend using discs recorded with the larger number of quantization bits. 

About folders and MP3/WMA/AAC/WAV files

- An outline of a CD-ROM with MP3/WMA/AAC/WAV files on it is shown below. Sub-folders are shown as folders in the folder currently selected.

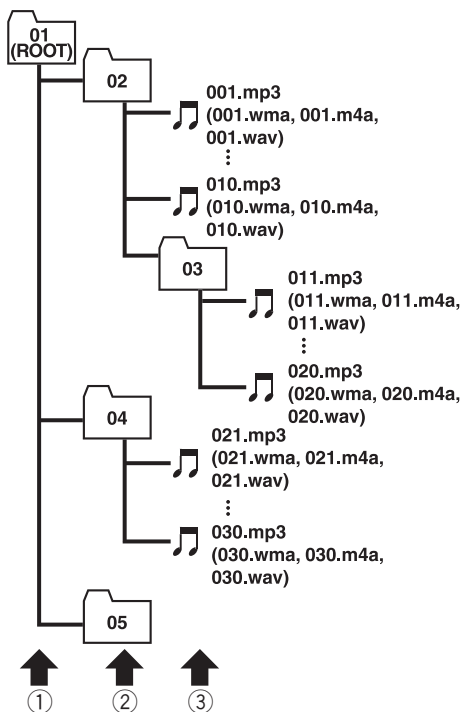

① First level

② Second level

③ Third level

Notes

- This unit assigns folder numbers. The user cannot assign folder numbers.
- It is not possible to check folders that do not include MP3/WMA/AAC/WAV files. (These folders will be skipped without displaying the folder number.)

Additional Information

- MP3/WMA/AAC/WAV files in up to 8 tiers of folders can be played back. However, there is a delay in the start of playback on discs with numerous tiers. For this reason we recommend creating discs with no more than 2 tiers.
- It is possible to play back up to 99 folders on one disc. ■

Additional Information

Terms

A2DP

A2DP is short for Advanced Audio Distribution Profile. This profile allows the high quality audio data of either stereo or monaural to be transmitted via Bluetooth wireless technology.

AAC

AAC is short for Advanced Audio Coding and refers to an audio compression technology standard used with MPEG 2 and MPEG 4.

AVRCP

AVRCP is short for Audio/Video Remote Control Profile. This profile enables interoperability between audio and video features of the Bluetooth device connected via Bluetooth wireless technology.

Bit rate

This expresses data volume per second, or bps (bits per second) units. The higher the rate, the more information is available to reproduce the sound. Using the same encoding method (such as MP3), the higher the rate, the better the sound.

Bluetooth

Bluetooth is a short-range wireless radio connectivity technology that is developed as a cable replacement for mobile phones, handheld PCs and other devices. Bluetooth operates in 2.4 GHz frequency range and transmits voice and data at speeds up to 1 megabit per second. Bluetooth was launched by a special interest group (SIG) that comprises of Ericsson Inc., Intel Corp., Nokia Corp., Toshiba and IBM in 1998, and it is currently developed by nearly 2 000 companies worldwide.

GAP

GAP is short for Generic Access Profile. This is a basic profile of Bluetooth wireless technology.

HFP

HFP is short for Hands Free Profile. This profile is used for hands-free phoning with the devices featuring Bluetooth wireless technology.

HSP

HSP is short for Head Set Profile. This profile is used for connecting headset and communication terminal via Bluetooth wireless technology.

ID3 tag

This is a method of embedding track-related information in an MP3 file. This embedded information can include the track title, the artist's name, the album title, the music genre, the year of production, comments and other data. The contents can be freely edited using software with ID3 Tag editing functions. Although the tags are restricted as to the number of characters, the information can be viewed when the track is played back.

ISO9660 format

This is the international standard for the format logic of CD-ROM folders and files. For the ISO9660 format, there are regulations for the following two levels.

Level 1:

The file name is in 8.3 format (the name consists of up to 8 characters, half-byte English capital letters and half-byte numerals and the “_” sign, with a file-extension of three characters).

Level 2:

The file name can have up to 31 characters (including the separation mark “.” and a file extension). Each folder contains less than 8 hierarchies.

Extended formats

Joliet:

File names can have up to 64 characters.

Romeo:

File names can have up to 128 characters.

Additional Information

Linear PCM (LPCM)/Pulse code modulation

This stands for linear pulse code modulation, which is the signal recording system used for music CDs and DVDs.

m3u

Playlists created using the “WINAMP” software have a playlist file extension (.m3u).

MP3

MP3 is short for MPEG Audio Layer 3. It is an audio compression standard set by a working group (MPEG) of the ISO (International Standards Organization). MP3 is able to compress audio data to about 1/10th the level of a conventional disc.

MS ADPCM

This stands for Microsoft adaptive differential pulse code modulation, which is the signal recording system used for the multimedia software of Microsoft Corporation.

Multi-session

Multi-session is a recording method that allows additional data to be recorded later. When recording data on a CD-ROM, CD-R or CD-RW, etc., all data from beginning to end is treated as a single unit or session. Multi-session is a method of recording more than 2 sessions on one disc.

Number of quantization bits

The number of quantization bits is one factor in the overall sound quality; the higher the “bit-depth”, the better the sound quality. However, increasing the bit-depth also increases the amount of data and therefore storage space required.

OPP

OPP is short for Object Push Profile. This profile is used for transferring the phonebook

data, schedule data and so on between devices featuring Bluetooth wireless technology.

Packet write

This is a general term for a method of writing on CD-R, etc., at the time required for a file, just as is done with files on floppy or hard discs.

SDP

SDP is short for Service Discovery Protocol. This protocol is to search for available services and service characteristics on other devices featuring Bluetooth wireless technology.

VBR

VBR is short for variable bit rate. Generally speaking CBR (constant bit rate) is more widely used. But by flexibly adjusting the bit rate according to the needs of audio compression, it is possible to achieve compression-priority sound quality.

WAV

WAV is short for waveform. It is a standard audio file format for Windows®.

WMA

WMA is short for Windows Media™ Audio and refers to an audio compression technology that is developed by Microsoft Corporation. WMA data can be encoded by using Windows Media Player version 7 or later. Windows Media and the Windows logo are trademarks or registered trademarks of Microsoft Corporation in the United States and/or other countries. ■

Additional Information

Specifications

General

Rated power source	14.4 V DC
	(allowable voltage range: 12.0 V to 14.4 V DC)
Grounding system	Negative type
Max. current consumption	10.0 A
Dimensions (W × H × D):	
DIN	
Chassis	178 × 50 × 161 mm
Nose	188 × 58 × 23 mm
D	
Chassis	178 × 50 × 166 mm
Nose	170 × 45 × 18 mm
Weight	1.7 kg

Audio/DSP

Maximum power output	50 W × 4
Continuous power output ...	22 W × 4 (50 Hz to 15 000 Hz, 5% THD, 4 Ω load, both channels driven)
Load impedance	4 Ω (4 Ω to 8 Ω allowable)
Preout max output level/output impedance	5 V/100 Ω
Loudness contour	+10 dB (100 Hz), +6.5 dB (10 kHz) (volume: -30 dB)
Equalizer (16-Band Graphic Equalizer):	
Frequency	20/31.5/50/80/125/200/315/500/800/1.25k/2k/3.15k/5k/8k/12.5k/20k Hz
Equalization range	±12 dB
Auto equalizer:	
(Front & rear & subwoofer 16 band graphic)	
Frequency	20/31.5/50/80/125/200/315/500/800/1.25k/2k/3.15k/5k/8k/12.5k/20k Hz
Equalization range	+6 dB to -12 dB
HPF (Front/rear):	
Frequency	50/63/80/100/125/160/200 Hz
Slope	0 (Pass)/-6/-12 dB/oct
Gain	0 dB to -24 dB/Mute
Subwoofer (stereo/mono):	
Frequency	50/63/80/100/125/160/200 Hz
Slope	-6/-12/-18 dB/oct
Gain	+6 dB to -24 dB/Mute
Phase	Normal/Reverse

CD player

System	Compact disc audio system
Usable discs	Compact disc
Signal format:	
Sampling frequency	44.1 kHz
Number of quantization bits	16; linear
Frequency characteristics ...	5 Hz to 20 000 Hz (±1 dB)
Signal-to-noise ratio	100 dB (1 kHz) (IEC-A network)
Dynamic range	95 dB (1 kHz)
Number of channels	2 (stereo)
MP3 decoding format	MPEG-1 & 2 Audio Layer 3
WMA decoding format	Ver. 7, 7.1, 8, 9, 10 (2ch audio) (Windows Media Player)
AAC decoding format	MPEG-4 AAC (iTunes® encoded only)
WAV signal format	Linear PCM & MS ADPCM

FM tuner

Frequency range	87.5 MHz to 108.0 MHz
Usable sensitivity	8 dBf (0.7 μV/75 Ω mono, S/N: 30 dB)
50 dB quieting sensitivity	10 dBf (0.9 μV/75 Ω mono)
Signal-to-noise ratio	75 dB (IEC-A network)
Distortion	0.3 % (at 65 dBf, 1 kHz, stereo)
	0.1 % (at 65 dBf, 1 kHz, mono)
Frequency response	30 Hz to 15 000 Hz (±3 dB)
Stereo separation	45 dB (at 65 dBf, 1 kHz)

AM tuner

Frequency range	531 kHz to 1 602 kHz (9 kHz)
	530 kHz to 1 640 kHz (10 kHz)
Usable sensitivity	18 μV (S/N: 20 dB)
Signal-to-noise ratio	65 dB (IEC-A network)

Bluetooth

Version	Bluetooth 1.2 certified
Output power	+4 dBm Max. (Power class 2)

Additional Information

Profile GAP (Generic Access Profile)
SDP (Service Discovery Protocol)
HSP (Head Set Profile)
HFP (Hands Free Profile)
A2DP (Advanced Audio Distribution Profile)
AVRCP (Audio Video Remote Control Profile)
OPP (Object Push Profile)

Infrared remote control

Wavelength 940 nm \pm 50 nm
Output typ; 12 mw/sr per Infrared LED



Note

Specifications and the design are subject to possible modifications without notice due to improvements. ■

PIONEER CORPORATION

4-1, MEGURO 1-CHOME, MEGURO-KU, TOKYO 153-8654, JAPAN

PIONEER ELECTRONICS (USA) INC.

P.O. Box 1540, Long Beach, California 90801-1540, U.S.A.

TEL: (800) 421-1404

PIONEER EUROPE NV

Haven 1087, Keetberglaan 1, B-9120 Melsele, Belgium

TEL: (0) 3/570.05.11

PIONEER ELECTRONICS ASIACENTRE PTE. LTD.

253 Alexandra Road, #04-01, Singapore 159936

TEL: 65-6472-7555

PIONEER ELECTRONICS AUSTRALIA PTY. LTD.

178-184 Boundary Road, Braeside, Victoria 3195, Australia

TEL: (03) 9586-6300

PIONEER ELECTRONICS OF CANADA, INC.

300 Allstate Parkway, Markham, Ontario L3R OP2, Canada

TEL: 1-877-283-5901

PIONEER ELECTRONICS DE MEXICO, S.A. de C.V.

Bldv.Manuel Avila Camacho 138 10 piso

Col.Lomas de Chapultepec, Mexico, D.F. 11000

TEL: 55-9178-4270

先鋒股份有限公司

總公司：台北市中山北路二段44號13樓

電話：(02) 2521-3588

先鋒電子（香港）有限公司

香港九龍尖沙咀海港城世界商業中心

9樓901-6室

電話：(0852) 2848-6488

Published by Pioneer Corporation.

Copyright © 2006 by Pioneer Corporation.

All rights reserved.

Printed in Thailand

<CRB2179-A/N> ES

<KMMZX> <06B00000>